

A Solar-Powered Fertigation System Based on Low-Cost Wireless Sensor Network Remotely Controlled by Farmer for Irrigation Cycles and Crops Growth Optimization

P. Visconti, R. de Fazio, P. Primiceri, D. Cafagna, S. Strazzella, and N. I. Giannoccaro

Abstract—Nowadays, the technological innovations affect all human activities; also the agriculture field heavily benefits of technologies as informatics, electronic, telecommunication, allowing huge improvements of productivity and resources exploitation. This manuscript presents an innovative low cost fertigation system for assisting the cultures by using data-processing electronic boards and wireless sensors network (WSN) connected to a remote software platform. The proposed system receives information related to air and soil parameters, by a custom solar-powered WSN. A control unit elaborates the acquired data by using dynamic agronomic models implemented on a cloud platform, for optimizing the amount and typology of fertilizers as well as the irrigations frequency, as function also of weather forecasts got by on-line weather service.

Keywords—precise farming, IoT devices, fertigation system; sensors, solar-powered WSN, data processing electronic boards

I. INTRODUCTION

THE intensive agriculture allows to satisfy the primary needs of a population in constant growth but, on the other hand, it has caused serious ecological damages such as deforestation, desertification, use of pesticides and fertilizers and consequently groundwater pollution. The United Nations, which estimate a population increase up to 9 billion people in 2050, have imposed to the agricultural technology further improvements and developments in production processes, in order to safeguard our planet [1]. The aim is to achieve sustainable agriculture from the ecological and environmental point of view and also in terms of economic compatibility; a key factor to obtain this aim is the correct use of various inputs such as fertilizers, water, plant protection products, etc., into the agricultural production processes.

Thanks to Internet of Things (IoT), a huge number of low cost and low power sensors can easily be deployed in farmlands, in order to gather precise climate and soil data and forward the collected data, by Internet connection, to the on-cloud IoT framework. In this context, some recent research works are described in [2-7]; in [8] the current state of technological solutions for agricultural applications as well as

the trends, architectures and open challenges are analyzed, whereas in [9] a survey of several researches applied to various agricultural and food production challenges is reported.

The innovative system, here proposed, is an energy self-sufficient fertigation system powered by photovoltaic energy, integrated with a low-cost WSN in order to monitor the crops directly on-field and to support farmers in the decision-making phases. The developed system aims to guarantee a rational use of fertilizers, water resources and consequently a reduction of the environmental impact. The solution allows the integration and optimized management of the traditional cropping systems with existing innovative technologies thanks to use of low-cost wireless electronic modules which both receive and process the data from connected sensors. The fertigation system calibrates the periodicity and fertilizers' amounts to be used in the irrigation and fertilization phases based on the agronomic models and on sensors data related to temperature and humidity of both soil and air. The designed WSN is distributed directly on the land and acquires the soil and environmental parameters sending the data to a central control unit. This last elaborates the incoming data provided by WSN and manages the fertigator's operating modes according to the meteorological service and agronomic models.

The manuscript is organized as follows: second paragraph includes an overview regarding the precision farming applications, techniques and employed devices in order to exploit the available resources in the best and most efficient way and also to satisfy the needs of cultivated crops with ultimate goal of optimizing their quantity and quality. In the following paragraph, we report a description of the realized solar powered fertigation system with technical details on the functionalities and different mechanical hydraulic and electrical systems; in the next paragraph, the design and operating modes of the low cost WSN and related sensors as well as used processing/communication electronic modules are illustrated and described. Also a detailed analysis of the electronic section for solar energy harvesting is provided for making WSN node almost autonomous from the energy point of view; in the final paragraph the conclusions are reported.

P. Visconti*, R. de Fazio, P. Primiceri, D. Cafagna and N. I. Giannoccaro are with University of Salento, Dept. of Innovation Engineering, Lecce, 73100, Italy (e-mail: paolo.visconti@unisalento.it-corresponding author).



II. OVERVIEW REGARDING PRECISION FARMING TECHNIQUES AND EMPLOYED IOT TECHNOLOGIES

In general, precision farming is a management system integrated through observations, measures and actions related to factors and dynamic variables in the agricultural production systems; it represents an agriculture management for optimizing the crop quality and yield, by using the necessary resources, according to the analysis of the different environmental and soil parameters. In this way, it is possible to increase the climatic and environmental sustainability, allowing to optimize the efficiency and quality of agricultural production. Other advantages deriving from the precision farming adoption are improvements of inputs exploitation resulting in better water and air quality, a real time monitoring of the crops' health state, an advanced traceability (info-tracing) from products' production to their consumption/sale and finally the availability of an on-line database for the development of a DSS (*Decision Support System*).

In 2012, a DSS for guiding the farmer about the decisions related to the management of downy mildew in organic vineyards, named *Vitebio.net*TM, was developed by the Institute of Entomology and Plant Pathology of the Catholic University of Piacenza. It is composed by a network of weather stations that measure environmental variables, a server repository that stores weather data and fungicide application schedule; some mathematical models use weather data and vineyard-specific information to predict the biological events relevant for decision making; in particular, the employed decision-making models simulate the risk for primary and secondary infections of *Plasmopara viticola* and therefore determine the optimum dose of copper to be applied depending on disease risk, residual coverage of the previous fungicide application, and grapevine growth and development [10].

In order to address the challenges associated with climate changes, the European wine industry established in 2013 the four-year *InnoVine* project. The climate change represents one of the most significant challenges facing the world of the future. In this context, some of the key challenges currently facing Europe's viticulture sector include the unwanted evolution of wine quality, the sustainability of the vineyards, because of environmental and pathogens-related stresses, the need to seriously reduce the use of pesticides on crops and to be mindful of the importance of meeting consumers' demands. The *InnoVine* project had the purpose to provide tools for the grape harvest's quality management, such as the identification of zones in the vineyards that have homogeneous or inhomogeneous behavior, in terms of phenology and harvest yield, by implementing a DSS for precision viticulture that allows the farmer to follow the physiological state of the vine in the field, on the basis of various monitoring tools such as imaging at different scales by using near-infrared tools [11]. Monitoring tools were developed to improve the assessment of flower numbers, berry color and composition, plant physiological states and the number of missing plants in a given vineyard. Ultimately, the aim was to aid the collection of data that will improve the prediction power of DSSs and therefore to assist growers in making decisions relating to the treatment, pruning and harvesting on vineyards [12].

Nowadays WSNs are spreading in agriculture due to their ability to produce a great amount of data concerning the monitoring of environmental and soil parameters (air and soil temperature and humidity, the leaves humidity, absorbed solar radiation by plants, atmospheric pressure, the wind speed and direction, the rain amount, etc.). The collected data allow to perform a constant crops' control and, at the same time, to carry out forecasts on future crops, thus deducing how to optimize the cultivation process and hence the quality and quantity of the cultivated products. The following Figs 1a and 1b show some examples of WSNs applied in an outdoor cultivated land and into a greenhouse respectively.

Generally, WSN nodes are equipped with programmable microcontrollers, because they are designed as modular structures, open both from the hardware and software point of views. As example, a modular sensor node, provided by *Libelium*, a leader company in this sector, is shown in Fig. 2a. The sensor node, named *Waspmote*, is provided with sensors for air and soil temperature and humidity, the solar visible radiation, wind speed and direction, rainfall, the atmospheric pressure, etc (for further information see <http://www.libelium.com/products/waspmote/>).

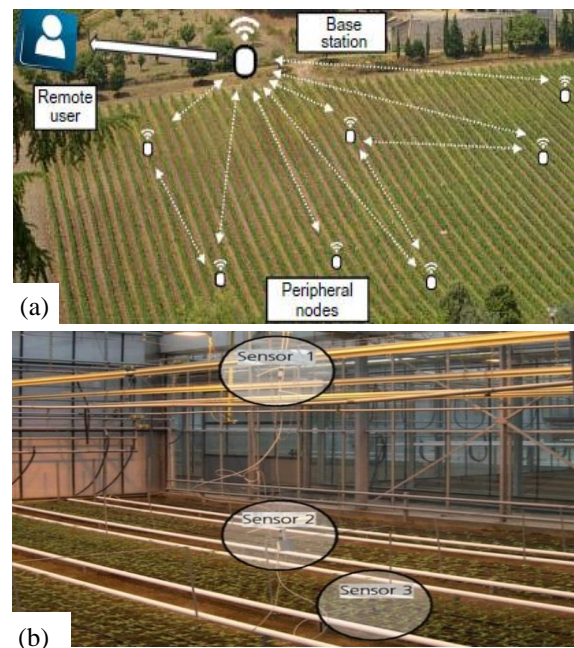

Fig. 1. Application of a WSN in an open land (a) and into a greenhouse (b).

In particular, *Waspmote* is an open source wireless sensors' platform specially focused on the implementation of low consumption operating modes, to allow the sensor nodes to be completely autonomous and battery powered, offering a variable life-time between 1 and 5 years depending on the duty cycle and the used technology for wireless data transmission. Because the devices have a modular architecture, they allow to install only the needed modules, as function of the particular application, thus optimizing costs. Therefore, all the designed modules (radios, sensor boards, etc) plug in *Waspmote* through sockets, as reported in Fig. 2b, where the ZigBee/802.15.4 module, used by the platform, is highlighted. In addition, in Fig. 2c, the used humidity sensor together with other sensors is shown connected to the electronic board.

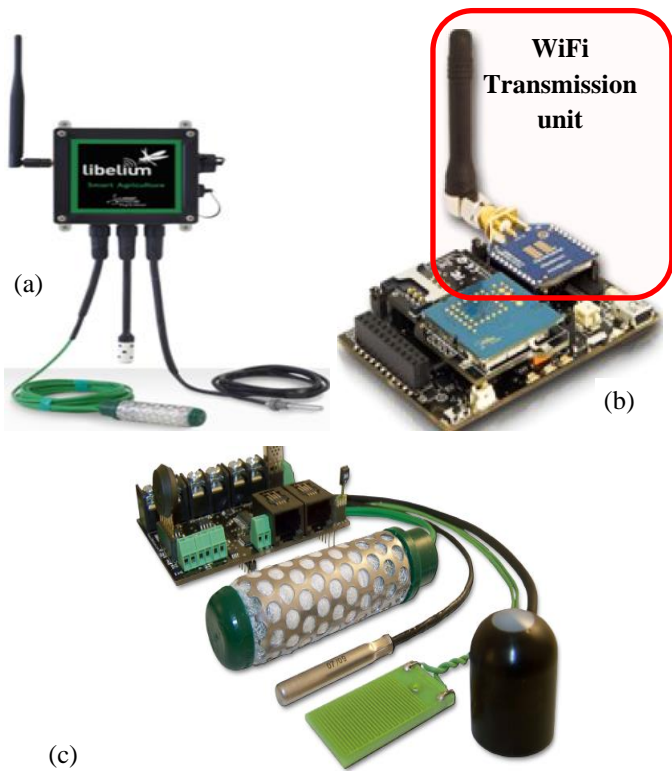

Fig. 2. Waspote sensor node provided by Libelium company with connected different sensors (a), the processing and transmission unit (b) and the sensors' kit used to detect the different parameters useful in the agriculture sector (c).

Each sensor node supports a wide class of transmission protocols for covering different distances ranges, making the WSN very useful for environmental monitoring applications. Many sensors' typologies can be connected to the generic sensor node for the ambient and soil parameters detection and not only: for instance, the sensors shown in Fig. 3 are both resistive leaf wetness sensors, featured by very high resistance in absence of condensation in their conductive combs and low resistance value when the sensor is completely submerged in water, so providing an output voltage inversely proportional to the humidity condensed on the combs.

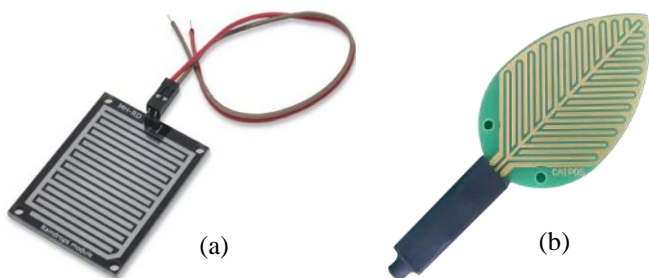

Fig. 3. Different leaf wetness sensors which provide an output a voltage value inversely proportional to the humidity condensed on their combs.

Fig. 4a shows a soil moisture resistive sensor provided by *Irrrometer* company consisting of two electrodes highly resistant to corrosion, embedded in a granular matrix below a gypsum wafer. The sensor resistance value is proportional to the soil water tension, a parameter dependent on moisture that reflects the pressure needed to extract the water from the ground (Fig. 4b). As the soil dries, water is removed from the sensor and the resistance value increases; conversely, when the soil is rewetted, the sensor resistance lowers.

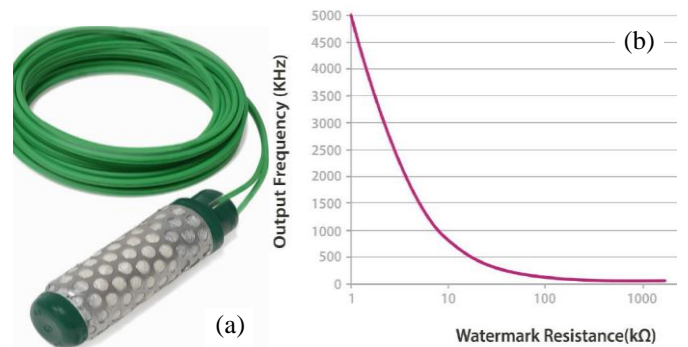

Fig. 4. View of the watermark soil moisture sensor (a) and output frequency of the Watermark sensor circuit with respect to the resistance of the sensor (b).

This type of sensors can be placed at different depths in the soil; in fact, the plants extract about 40% of the needed water for their supplying from the upper quarter of the volume of soil explored by their roots, 30% from the second quarter, 20% from the third quarter and only 10% from the last quarter, the deepest (see Fig. 5a). In fact, the measurement of water tension at the various depths is important to ensure that the different areas of soil have sufficient moisture content. Depending on crop typology, 2 or 3 sensors are sufficient to have complete information on soil state at different depths, as shown in Fig. 5a. Another sensor used to detect the soil temperature, is the PT1000 resistive sensor shown Fig. 5b; its resistance range is between approximately 920 Ω and 1200 Ω as function of soil temperature in the range [20 – 50] $^{\circ}$ C considered useful in agriculture applications. The analog voltage, provided as output from sensor, is processed by the analog-to-digital converter of microcontroller to which the sensor is connected.

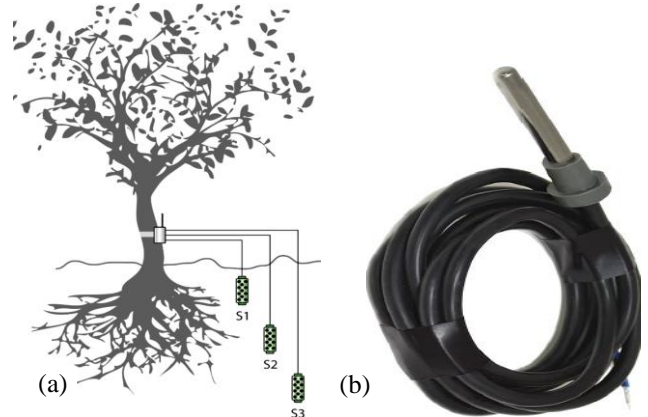

Fig. 5. Illustration of three watermark sensors placed at different depths (a), PT1000 temperature sensor typically used to detect the soil temperature (b).

In order to measure diameter of a stem or fruit, it is possible to use a dendrometer sensor (Fig. 6) provided by *Ecomatik* company; the operation of this kind of sensor is based on the variation of an internal resistance with the pressure that the growing of the trunk, stem, branch or fruit exerts on the sensor. The sensor provides an analog output proportional to the resistance variation, acquired by the analog to digital converter of the microcontroller to which the sensor is connected.

An important parameter to monitor for determining the soil conditions is pH; depending on soil pH values, it is possible to establish the crops type to cultivate. In fact, by measuring the soil pH, the degree of acidity or basicity of the solution,

circulating inside the soil porosity, in which the nutrients essential for crops growth are dissolved, can be established.

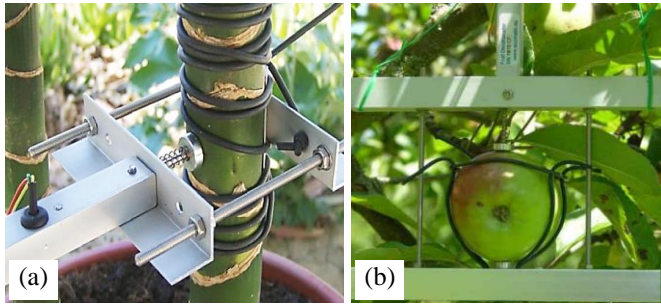

Fig. 6. Electronic dendrometer installed on a stem (a) and a fruit (b) for detecting in real time their growing.

The self-powered SQ-100 solar radiation sensor, provided by *Apogee Instruments company* and shown in Fig. 7b, is used to monitor the photo-synthesis processes. Solar radiation that drives photo-synthesis is called Photo-synthetically Active Radiation (PAR), defined as total radiation in the range [400 – 700]nm and often expressed as *Photo-synthetic Photon Flux (PPF)*, namely the photon flux (photons number from 400 nm to 700 nm) in units of micromoles per square meter per second ($\mu\text{mol m}^{-2} \text{s}^{-1}$ equal to microEinsteins per square meter per second). The sensors that measure PPF are often called *quantum sensors* due to the quantized nature of radiation, involved in physical interactions (e.g., absorption by photo-synthetic pigments). SQ-100 sensor, specifically calibrated for the detection of solar radiation, provides at its output a voltage proportional to the intensity of the light in the visible range of the spectrum. It presents a maximum output of 400mV under maximum radiation conditions and a sensitivity of $5\mu\text{mol m}^{-2}\text{s}^{-1} / \text{mV}$. The Fig. 7a reports a comparison between the responses to sun intensity of the sensor and that of a plant.

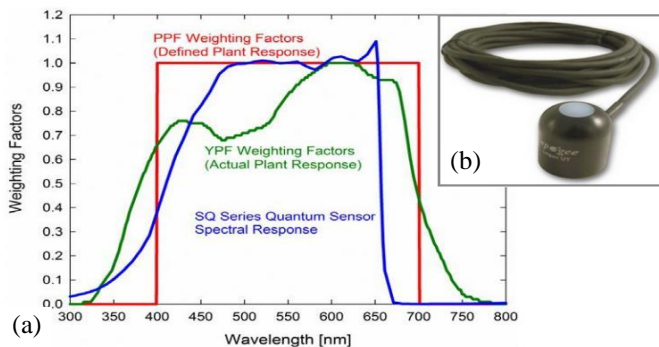

Fig. 7. Graph with radiation weighting factors for PPF in red (defined plant response to radiation), the yield photon flux (YPF) that is the measured plant response to radiation (in green) and response of the Apogee SQ Series quantum sensors in blue (a) and a picture of SQ-100 solar radiation sensor (b).

Besides the agriculture, the WSNs are employed in several applications such as environmental monitoring, structures monitoring (buildings, bridges, etc.), vehicular traffic, surveillance, in military applications, industrial equipment monitoring, in medical field and so on. As example, the above described sensor node, provided by *Libelium*, can be integrated with specific sensors shields, as function of the specific application and also with specific wireless modules depending on the application, including long range (3G /GPRS /

LoRaWAN / LoRa / Sigfox / 868 / 900MHz), medium range (ZigBee / 802.15.4 / WiFi) and short range (RFID / NFC / Bluetooth 4.0) detected data transmission [9, 13].

III. FERTIGATION SYSTEM'S DESCRIPTION

Aim of this section is provide an overview about the development, prototyping and testing of an innovative solar-powered fertigation system, useful for farms companies to monitor and control their productions, to follow the cultivation processes on crops and to have a traceability of the cultivated products. The realized fertigation system consists of physical modules electrically powered by a photo-voltaic power supply system and a cloud computing infrastructure for managing the physical modules in an automated way. In fact, by means of the informatics infrastructure, it is possible to control and activate the fertigation phases according to the crops type and their growth phase, to create a history of operations, to share data by using a tracking system with the reference community. In Fig.s 8 a prospective view of the whole fertigation system is shown with fertigator (A) (enlarged in the box on the right) and solenoid valves for selecting the sectors to be irrigated (B).

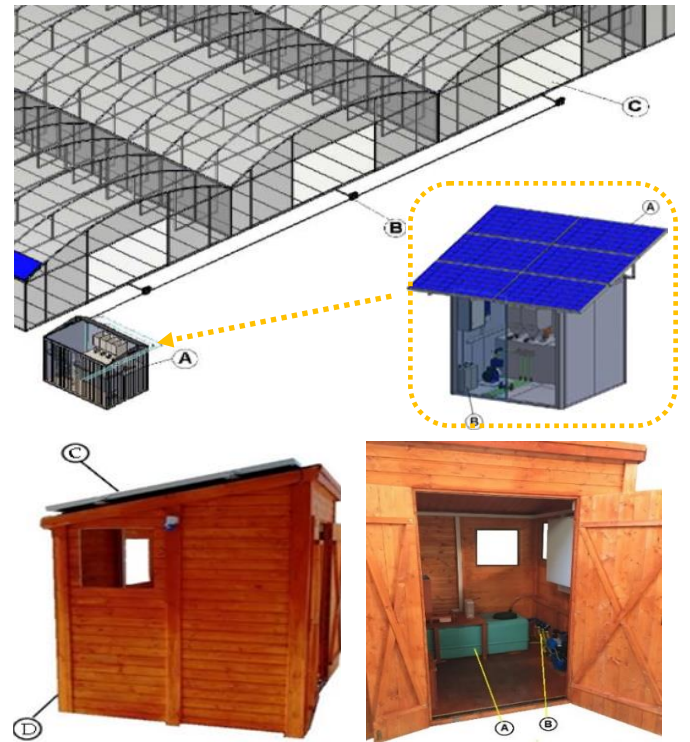

Fig. 8. Whole designed fertigation system for greenhouses and in zoomed area the solar powered wooden cottage with inside the fertigation system and batteries for energy storage (B); real images of wooden cottage (D) with inside electronic and mechanical sections with mixing tank (A), solenoid valves for selecting the land's sectors to be irrigated (B) and solar panels (C).

The fertigation system is powered by solar energy scavenged by using three photovoltaic panels (in poly-crystalline silicon, maximum output power for each equal to 200W) placed on the wooden cottage roof. The charge regulator (*Giaride 20A Solar Charge controller*), the *Crewell 3000 W/4000 W inverter* for the DC/AC conversion and the accumulation battery (a 12V 160Ah lead-acid *Leoch Adventurer AGM*) for storing the produced energy were placed inside the cottage with attached an electrical panel for the energy distribution to different

apparatus; also the electric panel contains all the switches and electrical protection, disconnection and control devices.

An electronic control unit gathers the data provided by WSN and drives the different fertigator sections; it is managed by a microcontroller with a high embedded memory for recording data sent wirelessly by the WSN that then are transmitted to a PC through a serial connection to be viewed locally by the user/farmer. The control unit compares received information with those stored in the database, thus defining type and concentrations of the fertilizers and regulating the irrigations timing. These operations are obtained properly driving the different hydraulic/mechanical sections for adjusting fertilizers quantities to be introduced into the aqueous solution in the bin.

Furthermore, the control unit drives the electric pump and solenoid valves, for correctly distributing the fertilizing solution into the different areas of the land; in fact, the system is designed in a modular way according to the extension of the land to cultivate. The definition of agronomic mathematical models is fundamental for processing data collected by the WSN and comparing them with those reported in the database in order to create a dynamic system for an optimal fertigation control. The agronomic database contains precise values related to fertigation needs for each crop type according to the seasonal period and growth phase; based on the agronomic database and WSN data related to soil and environmental, the control unit defines type and optimal quantities of fertilizer, the timing and the fertigation methods for each crop kind, with the purpose of optimizing water use and improving the quality and quantity of cultivated products.

IV. SENSOR NODE DESIGN AND WSN ARCHITECTURE

The proposed solar fertigation system supports its decisions (related to the amount and typology of fertilizers and irrigation timing) based on the physical parameters (of environment and soil) gathered by means of the WSN nodes located in the land. The designed WSN is constituted of sensors nodes for acquiring environmental and soil parameters and wirelessly sending them towards a central unit, where, by means of a microcontroller, they are processed. The central unit elaborates and compares the acquired data with proper thresholds, specific for each culture, to define the future actions. The network architecture considered more proper for this application is the tree architecture (Fig. 9), because it allows to reach some fundamental objectives, as:

- High flexibility and reliability: a malfunction of a WSN node doesn't preclude operation of the whole network;
- Realization of network clusters that could enclose different crops: in this way, the agronomic data for each culture could be acquired;
- Wireless coverage for high territorial extension, thanks to particular nodes configured as repeaters;

The technology employed for nodes communication is the Wi-Fi one because it allows to implement by using commercial devices a low cost WSN respecting the technical requirements. The WSN is interfaced with the central unit which carries out a series of operations as function of the data received from the sensor nodes; indeed, the system will start an irrigation or fertigation cycle only in the land's sections, where sensor

nodes will detect parameters levels lower than prefixed thresholds provided by the agronomic models.

The WSN is featured by two different typologies of nodes: source nodes with function of transmitting data acquired from sensors connected to it and coordinator nodes (in particular used in very large agricultural land) able to gather received information from neighboring nodes and to retransmit data to the central unit or to other WSN's nodes (as detailed in Fig. 9).

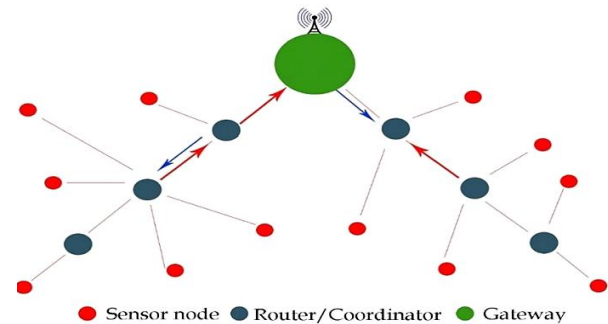

Fig. 9. Arrangement of sensor nodes within considered WSN with the different elements (sensor node, coordinator node, gateway) distinguished.

Specifically, each sensor node is based on the NodeMcu deviceKIT module that integrates the ESP8266 Integrated Circuit (IC) (as shown in Fig. 10); this electronic module is interfaced with sensors for acquiring soil and environmental parameters. In particular, a DHT22 (manufactured by Aosong Electronics company) digital sensor is employed for detecting the environmental temperature and humidity whereas a digital probe based on SHT11 (manufactured by Sensirion company) sensor, equipped with a proper metallic casing, is used for monitoring the soil temperature and moisture (Fig. 10). Furthermore, a capacitive analog sensor SEN0193 is used for detecting the soil moisture (manufactured by DFRobot company); its transfer function was experimentally determined and implemented in the ESP8266 IC's microcontroller for getting the soil moisture from the voltage value provided by the SEN0193 sensor [14-16].

The energy autonomy of each sensor node is provided by storage device (lithium battery or super-capacitor) recharged by small and flexible solar panels properly sized to obtain a significant node lifetime when no solar energy is available (more details later in this paragraph) (Fig. 10). In addition, given that the more energetically burdensome task is the communication phase between sensor nodes, for extending the WSN node lifetime, this task was managed according the following logic, as detailed in the flow-chart of Fig. 11 in which the operation of both sensors and coordinator nodes is summarized. Each node acquires data from sensors and transmits them to the corresponding coordinator node; at the transmission ending, the whole node (included the performed sensors) is brought in deep sleep modality for 30 minutes (or in any case for a time interval depending on the type of crop) to minimize the power consumption; after the cycle restarts. If a sensor node fails to connect with the coordinator node, the operation is repeated in reiterative way (every 2 minutes) until the connection is established. During the connection phase, the coordinator node receives data transmitted by relative sensor nodes; in addition, every 30 minutes, the coordinator node sends a data packet, containing collected information, towards the base station and then it comes back to the listening mode.

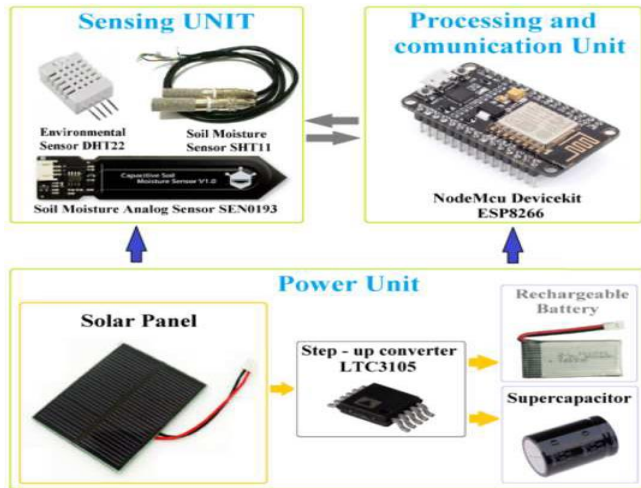

Fig. 10. Block diagram of the sensor node designed and tested in order to detect and transmit the soil and environmental parameters wirelessly.

More in detail always referring to the flowchart shown in Fig. 11, the first operation performed by sensor node (included in the block named “*Starting of sensor node*”) regards the inclusion of libraries needed for interfacing with DHT22 and SHT11 digital sensors. After, in the block “*Searching for sensor node*”, the node’s ESP8266 module set in client modality by using libraries named `<ESP8266WiFi.h>` and `<ESP8266HTTPClient.h>` tries to connect to the network generated by coordinator node in server modality. Also for reducing the WSN node power consumption, the used sensors were fed by common GPIO (General Purpose Input Output) pins set as output that during the deep sleep period, are put to low level (0V), as shown in Fig. 12.

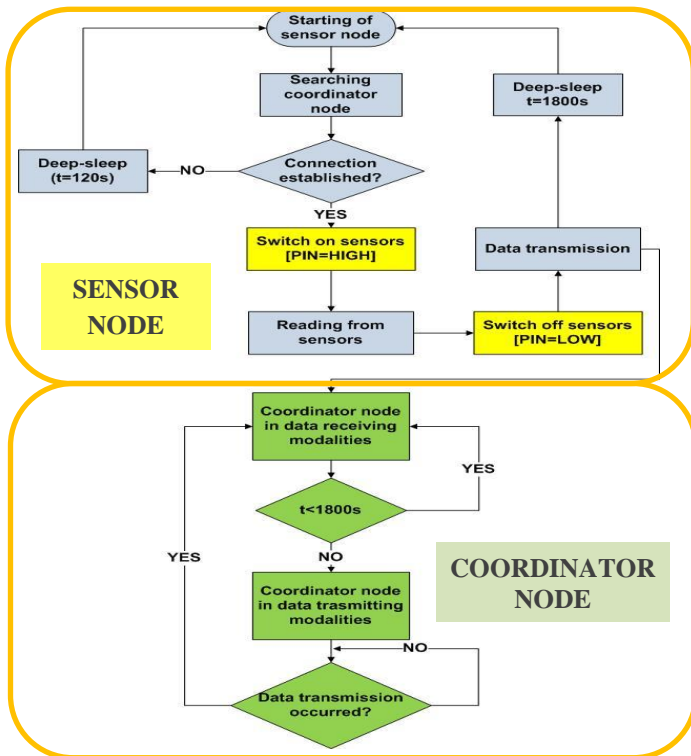

Fig. 11. Flowchart with represented the communication operations between a generic sensor node and the corresponding coordinator node.

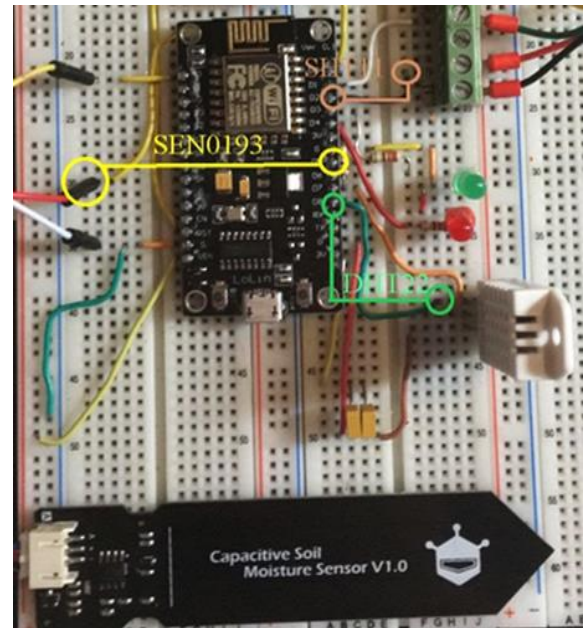

Fig. 12. View of realized sensor node with highlighted the GPIOs, set as output, used for power supplying the sensors.

Thereby the connected sensors are activated only when the nodeMcu establishes connection with the coordinator node; after the ESP8266 IC’s microcontroller calls the function `readDHT_SEN0193Sensor_SHT11()` with inside the methods for interfacing the different sensors connected to WSN node. Afterwards, the function `buildDataStream()` arranges the acquired data from sensors inside a packet, as reported in Fig. 13; specifically, this method converts each acquired data in string format and concatenates each of them with the relative argument name. Finally, the different couples (argument name and argument) relative to the different acquired data are included a single data packet. Furthermore, a sensor node ID number is assigned to the data packet, enabling to the coordinator node the identification of incoming data source. As reported in the flowchart of Fig. 11, if the data packet transmission has success, the sensor node enters in deep-sleep modality through the `hibernate()` method that firstly switches off sensors connected to node and, then brings the ESP8266 module in deep sleep modality by calling the `ESP.deepSleep()` function for a set time interval in microseconds (as shown in the portion of the developed firmware of Fig. 14).

```
void buildDataStream() {
  data ="Identificativo Nodo Sensore=";
  data += String (Identificativo_Nodo_Sensore);
  data += "&Temperatura ambientale=";
  data += String(T);
  data += "&Umidità ambientale=";
  data += String(U);
  data += "&Umidità del terreno=";
  data += String(UT);
  data += "&Temperatura del terreno=";
  data += String(T_D);
  data += "&Umidità del terreno 2=";
  data += String(UT_D);
  Serial.println("- data stream: "+data);
}
```

Fig. 13. Firmware section related to `buildDataStream()` function for arranging data acquired from sensors connected to WSN node into a packet to be transmitted to coordinator node.

```

void hibernate() {
    digitalWrite(4,LOW); //switch off the SEN0193 soil moisture sensor
    digitalWrite(15,LOW); //switch off the DHT22 temperature and moisture sensor
    digitalWrite(2,LOW);
    digitalWrite(0,LOW);
    delay(100); //wait 100ms, then disconnect the sensor node from Wi-Fi network and put it
    WiFi.disconnect(); in //deep sleep modality 30minutes
    ESP.deepSleep(sleepInterval*60000000, WAKE_RF_CAL);
    delay(100);
}
    
```

Fig. 14. Firmware section related to hibernate() method that switches off the sensors connected to node and then brought them in deep sleep mode for 30'.

Conversely, if the sensor node is not able to establish a connection with the coordinator node (because the latter is busy with the transmission towards another WSN node or to the central unit or due to the absence of network), a different procedure is actuated. Namely the sensor node attempts to establish the connection up to 20s and, if this operation fails, the node brings itself in deep sleep modality, by calling the *hibernateFailToConnect()* method, for a time interval defined *failConnectRetryInterval* (set by default to 120s). After, the sensor node retries newly to establish the connection with the coordinator node in iterative way till it is obtained.

After a first implementation in the research laboratory of the sensor node shown in Fig. 15, for improving the technical features and its energy autonomy before the real testing on field, a small flexible photovoltaic panel in amorphous silicon (with a maximum deliverable power of 1,5 Watt, open-circuit voltage of 2.5V and conversion efficiency of about 10%) was employed for scavenging the energy needed for the node operation (Fig. 16a). The solar panel was interfaced with the storage device by means of a conversion regulation circuit, based on DC-DC LTC3105 step-up converter (manufactured by Linear Technology); exactly, we used the demonstration circuit LT DC1587A (shown in Fig. 17b) based on the LTC3105 boost converter, described in detail below.

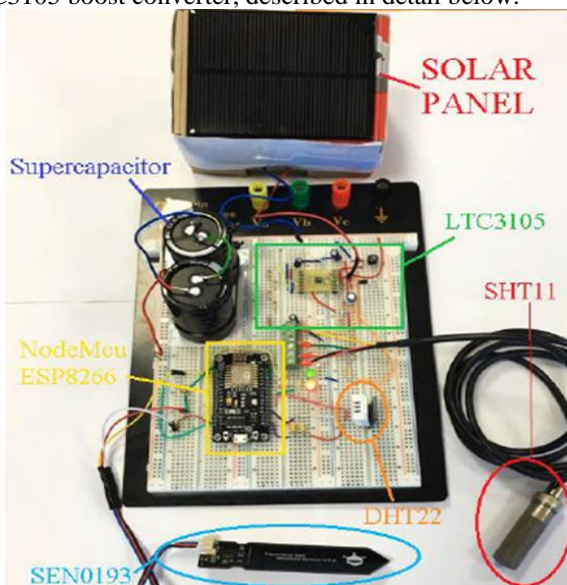

Fig. 15. Realized prototype sensor node equipped with 90 F super-capacitor recharged by a solar panel through the DC-DC step-up converter LTC3105.

The energy provided by the solar panel was stored either in a super capacitor or rechargeable LiPo battery; in particular, for ensuring up to 8 days node's autonomy (without any

availability of solar energy, surely an unrealistic extreme case), a 90 Farad 3.6 Volt (maximum voltage equal to 5.6 Volt) super-capacitor was selected (Fig. 16b) or, as preferable alternative to the previous one given its smaller size, a 100 mAh 3.7 Volt single-cell lithium-polymers battery (Fig. 16c) for ensuring the same autonomy.

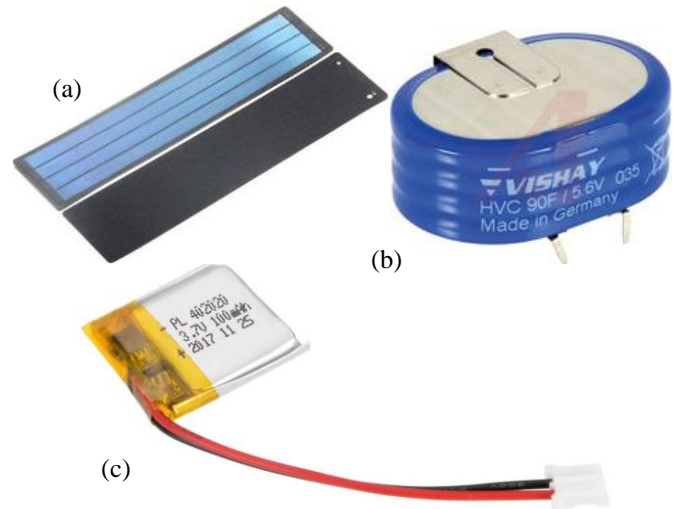

Fig. 16. Images of flexible solar panel in amorphous silicon employed to harvest the solar energy (a), of the 90 Farad 3.6 Volt super-capacitor and of the 100 mAh 3.7 Volt single-cell lithium-polymers battery (c) both for storing the harvested energy, ensuring up to 8 days node's autonomy.

The LTC3105 is a DC/DC step-up converter featured by high efficiency and low start-up voltage; specifically, a 250mV start-up capability and the integrated user-programmable Maximum Power Point Controller (MPPC) allow to maximize the energy that can be extracted from any power source, in particular from low voltage, high impedance alternative power sources as photovoltaic cells, TEGs (Thermo-Electric Generators) and fuel cells (Fig. 17a). The employed DC1587A circuitual solution is a demonstration board properly optimized for power source featured by high impedance and very low voltage level (Fig. 17b). It is essentially based on the IC LTC3105 boost converter and LDO regulator, which is able to operate with input voltage level as low as 250mV up to 5V; furthermore, the regulator integrates the MPPC circuit with programmable set point in order to maximize the extraction from any conditions. In fact, by connecting a resistor from the MPPC pin to GND, the MPPC loop can be activated allowing the user to set the optimal input voltage operating point for a given power source. The MPPC loop allows to adjust the average current through the inductor for avoiding that the input voltage drops below the MPPC threshold; this voltage values can be set considering that a 10µA constant current flow through the resistor connected to the MPPC pin. Hence, the MPPC set point is given as:

$$V_{MPPC} = 10\mu A * R_{MPPC} \tag{1}$$

In addition, for photovoltaic application, a diode can be used to set the MPPC threshold in order to track the solar cell over-temperature; referred to the DC1587A board, this could be obtained by setting the MPPC jumper on DIODE position and connecting to the DIODE connector (Fig.s 17b and 17c) a series of RMPPC resistor and a sensing diode, thermally coupled with the solar panel.

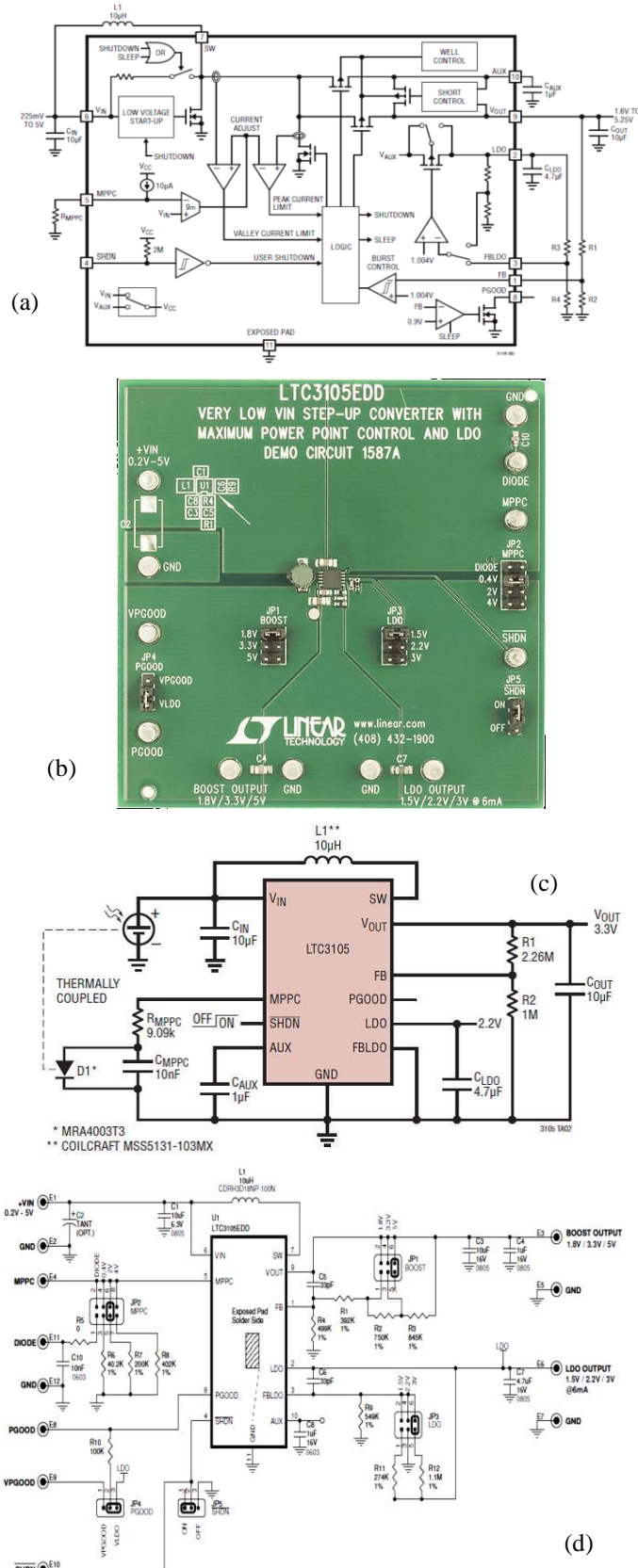

Fig. 17. Block diagram of LTC3105 booster DC/DC converter produced by Linear Technology (a), top view of the employed demonstration board DC1587A based on the LTC3105 DC/DC boost converter (b), typical circuitual scheme with LTC3105 boost converter providing 3.3V output from single-cell photovoltaic source with temperature tracking (c) and the circuitual scheme of the demonstration board DC1587A (d).

As already reported, the power source employed for feeding the sensor node is a flexible photovoltaic cell based on amorphous silicon, featured by dimensions 197mm * 97mm * 0.8 mm, maximum electric power of 1.5 W, short-circuit current of 950mA, open-circuit voltage of 2.5V and an estimated conversion efficiency of about 10%. Therefore, the MPPC set point can be set to a voltage level of 1V, thus resulting in a value of the R_{MPPC} of:

$$R_{MPPC} = \frac{V_{MPPC}}{10\mu A} = \frac{1V}{10\mu A} = 100K\Omega \quad (2)$$

The photovoltaic panel has to be connected to the VIN pin of LTC3105 through the +VIN pin of the DC1587A board whereas the \overline{SHDN} jumper on DC1587A board to the \overline{SHDN} control pin (active low input that places the IC into low current shutdown mode) of the LTC3105, that allows to enable or disable the regulator; if the jumper is in OFF position, the \overline{SHDN} pin is connected to ground and the regulator is disabled, whereas if the \overline{SHDN} jumper is in ON position, the regulator is enabled by integrated 2M Ω pull-up resistor of IC LTC3105.

Furthermore, the DC1587A board allows by BOOST jumper to select the voltage to be set on the OUTPUT pin, where the storage device (super-capacitor or lithium battery) has to be connected (Fig. 16 and Fig.s 17b, 17d); in particular, the output voltage can be set to three different values: 1.8V, 3.3V and 5V. Because the nodeMCU board, core of the designed sensor node, needs a power supply voltage of 3.3V, the BOOST jumper was set on 3.3V position, voltage to which the storage device has to be charged.

The LDO pin of DC1587A board refers to the integrated LDO (Low-dropout regulator) of the LTC3105 regulator providing a regulated 6mA rail to external microcontrollers and sensors while the main output is charging. The voltage level provided on LDO pin can be set on three different values (1.5V, 2.2V and 3V) based on the position of the LDO jumper, that changes the feedback resistors values between LDO and FBLDO pins of the LTC3105.

In addition, the evaluating board is equipped with an open-drain power good (PGOOD) indicator, for showing when the VOUT is in the regulation phase; the voltage level of this indicator can be set by means of PGOOD jumper of the DC1587 board. Whether the jumper is in VLDO position, the high logic level of PGOOD indicator is equal to the VLDO level, whereas if the jumper is brought in VPGOOD position, the PGOOD indicator voltage level can be set by fixing the desired voltage on VPGOOD pin of the board.

V. DATA ACQUISITION FROM SENSOR NODES AND TESTING OF THE WHOLE FERTIGATION SYSTEM

The testing of designed WSN was carried out transmitting the sensors data to the Matlab-based properly developed on-cloud platform. This cloud service necessitates the assignment to the communication channel of an admission key (application programming interface or API key). Indeed, the platform is arranged in communication channels, public or private, and each coordinator node can communicate with the platform by http requests. In this way, the coordinator node collects data from the joined sensor nodes and transmits them, by Wi-Fi connection, on the on- cloud framework, where they

can be showed in real time or stored on the data-base for a successive analysis.

In Fig.18 just an example of the temporal trends for a short time interval was displayed related to the physical quantities (environmental and soil moisture and temperature) acquired by a generic node (without any processing then performed by the software platform) and then delivered on a channel of the developed on-cloud platform through the coordinator node, so demonstrating the correct operation of data acquisition and transmission phases by the WSN [16-18].

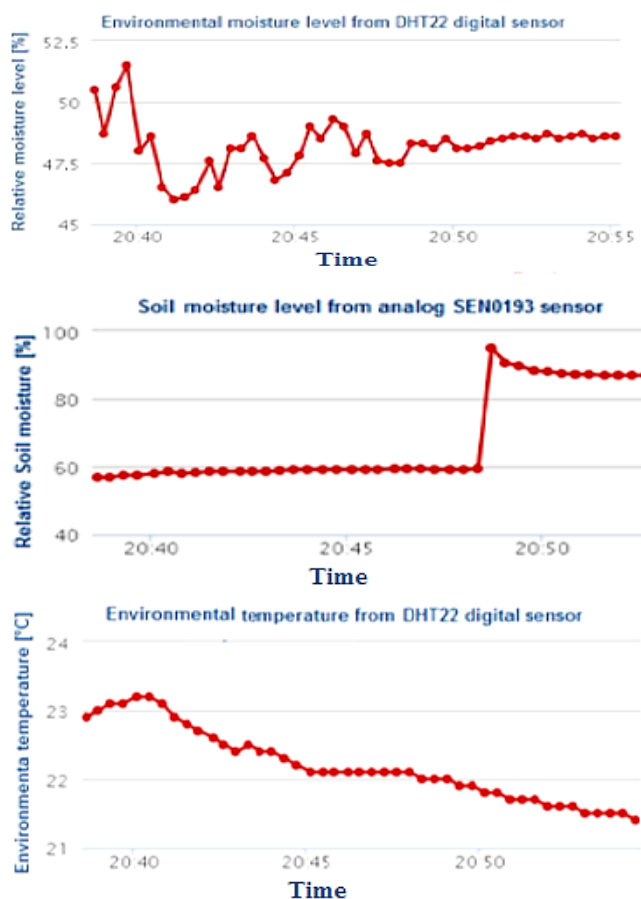

Fig. 18. Experimental data' plots (soil moisture, environmental temperature and moisture) acquired by a generic sensor node.

Finally, in order to test the correct operation of the developed fertigation system integrated with the sensor nodes installed in the cultivated ground and with the software application which allows the farmer an optimized management of fertigation cycles, different campaigns of measures have actually been carried out on cultivated agricultural land and the positive achieved results certify the correct functioning of the hardware and software sections developed and presented in this work.

VI. CONCLUSIONS

In this work, we have reported on the design of a remotely managed solar-powered automated fertigation system that combines the modern technologies with the necessity of the agricultural sector, resulting in a low environmental impact thanks to saving water and fertilizers consumption and to the harvesting of solar energy for feeding the control electronic

unit and sensors of the WSN. A low-cost WSN, almost autonomous from the energy point of view, monitors and transmits locally or towards the on-cloud software platform the detected soil and environmental parameters for checking crops growth directly on field and for sustaining farmers in the decision-making phases connected to the growth processes of the cultivated crops.

REFERENCES

- [1] Department of Economic and Social Affairs of UN, "The 2015 Revision, Key Findings and Advance Tables," *Population and Development Review*, vol. 41, no. 3, 2015, pp. 557–561. ESA/P/WP.241. 2015
- [2] T. Ojha, S. Misra and N. S. Raghuwanshi, "Wireless sensor networks for agriculture: The state-of-the-art in practice and future challenges," *Computers and Electronics in Agriculture*, vol. 118, pp. 66–84, 2015. DOI: 10.1016/j.compag.2015.08.011.
- [3] Z. Liqiang, Y. Shouyi, L. Leibo, Z. Zhen and W. Shaojun, "A Crop Monitoring System Based on Wireless Sensor Network," *Procedia Environmental Sciences*, vol. 11 (B), pp. 558–565, 2011.
- [4] K. M. Ramadan, M. J. Oates, J. Molina-Martinez and A. R. Canales, "Design and implementation of a low cost photovoltaic soil moisture monitoring station for irrigation scheduling with different frequency domain analysis probe structures," *Computers and Electronics in Agriculture*, vol. 148, pp. 148–159, 2018. DOI: 10.4148/2378-5977.1087.
- [5] R. S. Romaniuk, "IoT – review of critical issues," *International Journal of Electronic and Telecommunications*, vol. 64, no. 1, pp. 95–102, 2018. DOI: 10.24425/118153.
- [6] B. D. Fataniya, A. Sood, D. Poddar and D. Shah, "Implementation of IoT based Waste Segregation and Collection System," *International Journal of Electronic and Telecommunications*, vol. 65, no. 4, pp. 579–584, 2019. DOI: 10.24425-ijet.2019.126321.
- [7] V. Savani, A. Mecwan, J. Patel and P. Bhatasana, "Design and Development of Cost effective Automatic Fertilization System for Small Scale Farm," *International Journal of Electronic and Telecommunications*, vol. 65, no. 3, pp. 353–358, 2019. DOI: 10.24425-ijet.2019.126321
- [8] J. Polo, G. Hornero, C. Duijneveld, A. García and O. Casas, "Design of a low-cost Wireless Sensor Network with UAV mobile node for agricultural applications," *Computers and Electronics in Agriculture*, vol. 119, pp. 19–32, 2015. DOI: 10.1016/j.compag.2015.09.024 .
- [9] J. M. Talavera, L. E. Tobón, J. A. Gómez, M. A. Culman, J. M. Aranda, D. T. Parra, L. A. Quiroz, A. Hoyos and L. E. Garreta, "Review of IoT applications in agro-industrial and environmental fields," *Computers and Electronics in Agriculture*, vol. 142 (A), pp. 283–297, 2017. DOI: 10.1016/j.compag.2017.09.015 .
- [10] T. Caffi, S. E. Legler, F. Salinari, L. Mariani and V. Rossi, "Vitebio.Net™: La Web Assistance per il Controllo della Peronospora in Viticoltura Biologica," *ATTI Giornate Fitopatologiche*, vol. 2, pp. 405–412, 2012.
- [11] J. Martínez-Lüscher, T. Kizildeniz, V. Vučetić, Z. Dai, E. Luedeling, C. van Leeuwen, E. Gomès, I. Pascual, J. J. Irigoyen, F. Morales and S. Delrot, "Sensitivity of Grapevine Phenology to Water Availability, Temperature and CO₂ Concentration," *Frontiers in Environmental Science*, vol. 4, no. 48, pp. 1-14, 2016. DOI: 10.3389/fenvs.2016.00048
- [12] Z. G. Cerovic, G. Latouche, H. K. Nguyen, E. M. Fadaili, M. Le Moigne and N. Ben Ghazlen, "CUBA: An internet-based software application for berry anthocyanins units' conversion for viticulturists, oenologists and physiologists," *Computers and Electronics in Agriculture*, vol. 103, pp. 122–126, 2014. DOI: 10.1016/j.compag.2014.02.012
- [13] P. Visconti, B. Sbarro, P. Primiceri, R. de Fazio, A. L. Ekuakille, "Design and Testing of a Telemetry System Based on STM X-Nucleo Board for Detection and Wireless Transmission of Sensors Data Applied to a Single-Seat Formula SAE Car," *International Journal of Electronic and Telecommunications*, vol. 65, no. 4, pp. 671–678, 2019.

- [14] H. M. Jawad, R. Nordin, S. K. Gharghan, A. M. Jawad and M. Ismail. "Energy-Efficient Wireless Sensor Networks for Precision Agriculture: A Review," *Sensors*, vol. 17, no. 8, 2017. DOI: 10.3390/s17081781, 1-45.
- [15] P. Visconti, P. Primiceri and C. Orlando, "Solar Powered Wireless Monitoring System of Environmental Conditions for Early Flood Prediction or Optimized Irrigation in Agriculture," *ARPJ Journal of Engineering and Applied Sciences*, vol. 11, no. 7, pp. 4623-4632, 2016.
- [16] P. Visconti, P. Primiceri, R. Ferri, M. Pucciarelli, E. Venere, "An overview on state-of-art energy harvesting techniques and related choice criteria: a WSN node for goods transport and storage powered by a smart solar- based EH system," *International. Journal of Renewable Energy Research*, vol. 7, no. 3, pp. 1281-1295, 2017.
- [17] P. Visconti, R. de Fazio, P. Costantini, S. Miccoli, D. Cafagna, "Arduino-based solution for in-car-abandoned infants' controlling remotely managed by smartphone application," *Journal of Communications Software and Systems*, vol. 15, no. 2, pp. 1-14, 2019. DOI: 10.24138/jcomss.v15i2.691.
- [18] R.O. Schoeneich, M. Golański, D. Zgid, M. Franciszkiewicz, M. Kucharski, "RBCP-WSN: The Reliable Bidirectional Control Protocol for Wireless Sensor Networks", *International Journal of Electronic and Telecommunications*, vol. 63, no. 2, pp. 201-207, 2017. DOI: 10.1515/eletel-2017-0027.