

An Autonomous Wearable Sensor Node for Long-Term Healthcare Monitoring Powered by a Photovoltaic Energy Harvesting System

Saeed Mohsen , Abdelhalim Zekry , Khaled Youssef, and Mohamed Abouelatta 

Abstract—In this paper, an autonomous wearable sensor node is developed for long-term continuous healthcare monitoring. This node is used to monitor the body temperature and heart rate of a human through a mobile application. Thus, it includes a temperature sensor, a heart pulse sensor, a low-power microcontroller, and a Bluetooth low energy (BLE) module. The power supply of the node is a lithium-ion rechargeable battery, but this battery has a limited lifetime. Therefore, a photovoltaic (PV) energy harvesting system is proposed to prolong the battery lifetime of the sensor node. The PV energy harvesting system consists of a flexible photovoltaic panel, and a charging controller. This PV energy harvesting system is practically tested outdoor under lighting intensity of 1000 W/m². Experimentally, the overall power consumption of the node is 4.97 mW and its lifetime about 246 hours in active-sleep mode. Finally, the experimental results demonstrate long-term and sustainable operation for the wearable sensor node.

Keywords—energy harvesting, healthcare monitoring, wearable sensor nodes, photovoltaic, Bluetooth low energy (BLE)

I. INTRODUCTION

TODAY, wearable sensor nodes are becoming more popular in medical applications, such as healthcare monitoring [1,2]. Further, these sensor nodes introduce an important concept used in Internet of things (IoT) applications [3-5]. Supplying power is a critical issue for wearable sensor nodes because of the limited lifetime of their batteries [6-9]. There are several energy sources available, such as photovoltaic energy, thermal energy, radio frequency (RF) energy, and piezoelectric energy [10-14]. Photovoltaic energy is a promising solution due to its higher power density among these sources [15]. Therefore, the battery lifetime of the sensor nodes should be enhanced by effective PV energy. Hence, a perpetual photovoltaic energy harvesting system is implemented to provide efficient power to solve the power-supplying problem.

In the literature, many wearable sensor nodes with energy harvesting systems were introduced to continuously measure the vital healthcare data of the human body [16-19]. Thang Viet and Young Chung presented a sensor node in [16], which was designed with an Electrocardiography sensor and Photoplethysmography sensor. The sensor node was based on the HC-06-4.2 GHz wireless module and powered by a 500 mAh battery. However, this node had a limited lifetime of 41

hours and consumed high power (41.25 mW). In [17], M. Dai et al. introduced a sensor node for vital-signal monitoring, which has only one Electrocardiogram (ECG) sensor and is powered by a 310 mAh battery. It had a lifetime of 31 hours and its power consumption was about 29.74 mW. J. C. Lim et al. in [18], proposes a sensor node, containing a low temperature sensor, XBee, and a battery with a capacity of 1500 mAh, but the lifetime of this node was 40 hours, its power consumption was 91.41 mW, and it was not wearable. In [19], Taiyang-Wu et al. presented a flexible wearable sensor node used with a super-capacitor with voltage of 5.4 V. The sensor node continuously operates only for 12 hours and consumed power of 28.98 mW. It includes a Photoplethysmogram (PPG) sensor, an accelerometer, and a micro-SD card memory.

In this regard, the main aim of this paper is prolonging the battery lifetime of the developed wearable sensor node. Thus, a novel software algorithm is implemented to extend the lifetime and save the power consumption of the node. The power consumption of the sensor node is reduced from 64.68 to 4.97 mW and its lifetime is increased from 26.5 to 246 hours. In addition, a PV system is developed to harvest Photoenergy for the battery of the node. Moreover, the proposed node offers a long-term operation for healthcare monitoring using BLE wireless technology. The sensor node is also worn continuously without battery replacement.

This paper is organized as follows: Section II presents the design of the developed wearable sensor node with a PV energy harvesting system. Section III depicts the hardware architecture of the developed wearable sensor node. Section IV introduces the implementation of the developed wearable sensor node software. Section V shows the experimental results of this work. Section VI discusses the results. Finally, the conclusion of the paper is given in section VII.

II. WEARABLE SENSOR NODE WITH ENERGY HARVESTING

This paper introduces a design for a wearable sensor node with a PV energy harvesting system. Fig. 1 illustrates a block diagram of the wearable sensor node with a PV energy harvesting system. The system block diagram consists of two major parts: the first one is the PV energy harvesting system, which is composed of a flexible PV panel to detect the light, and a charging controller to regulate the output voltage of

Saeed Mohsen is with the Faculty of Engineering, Ain Shams University, Cairo, Egypt (e-mail: g17082131@eng.asu.edu.eg).

Abdelhalim Zekry is with the Faculty of Engineering, Ain Shams University, Cairo, Egypt (e-mail: aaazekry@hotmail.com).

Khaled Youssef is with the Faculty of Navigation Science and Space Technology, Beni Suef University, Cairo, Egypt (e-mail: khaled.youssef@nsst.bsu.edu.eg).

Mohamed Abouelatta is with the Faculty of Engineering, Ain Shams University, Cairo, Egypt (e-mail: m.abouelatta@eng.asu.edu.eg).



a rechargeable battery that is used as a backup power supply in the absence of light. The wearable sensor node is the second part that contains a microcontroller unit for processing the signals, a body temperature sensor to sense the temperature, a heart pulse sensor to measure the beats, and low energy Bluetooth that is used to transmit the vital data of the human body. This node is connected to an android application to monitor healthcare data on a mobile device.

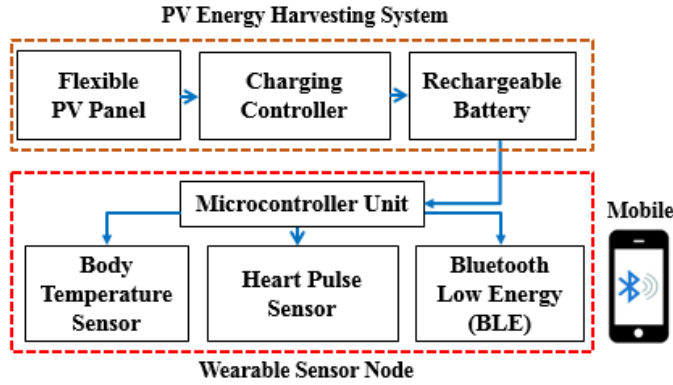

Fig. 1. Block diagram of the developed wearable sensor node with a photovoltaic energy harvesting system.

A. Power Calculations Without Photovoltaics

The proposed sensor node operates in two modes: active and sleep. Here, the total operation period of the node is (T). In the active mode, (I_{on}) is the current consumption of the node, and its period is (T_{on}). In sleep mode, (I_{sleep}) is the current consumption of the node, and its period is (T_{sleep}). Hence, the average current ($I_{average}$) of the two modes of the sensor node is calculated through Eq. (1). The lifetime in which the battery (T_B) can supply the wearable sensor node with energy is estimated by Eq. (2), where ($C_{battery}$) is the capacity of a battery: -

$$I_{average} = [(I_{on} \times T_{on}) + (I_{sleep} \times T_{sleep})] / T \quad (1)$$

$$T_B = C_{battery} / I_{average} \quad (2)$$

Theoretically, a case study is estimated from the Eqs. (1) and (2). According to calculations, the total operating period (T) of the node is presumed to be one hour. In active mode, the current consumption (I_{on}) of the node is assumed to be 19.65 mA during a period (T_{on}) of 60 seconds. In sleep mode, the current consumption (I_{sleep}) of the node is supposed to be 1.15 mA, and the node operates for a period (T_{sleep}) of 3540 seconds. Thus, $I_{average} = [(19.65 \text{ mA} \times 60 \text{ s}) + (1.15 \text{ mA} \times 3540 \text{ s})] / 3600 \text{ s} = 1.458 \text{ mA}$. The operating voltage (V) of the node is assumed 3.3 V. Thus, the corresponding average power and energy are, respectively, 4.811 mW and 17.32 Joules. Hence, if the battery capacity is assumed to be 4800 mAh. Therefore, the total lifetime (T_B) for the battery of the sensor node is calculated to be $4800 / 1.458 = 3292.18$ hours (137.17 days).

B. Power Calculations With Photovoltaics

The energy from the photovoltaic panel is estimated by Eq. (3), where (P_{pv}) is the PV panel power, and (t) is the time in

which the PV panel is providing energy. Further, the theoretical stored energy (E_{stored}) by the battery of the sensor node is calculated using Eq. (4), where the (V_{node}) is the battery voltage, (I_{node}) is the node consumed current, and (t_{node}) is the time in which an energy consumed from the battery. In addition, the time required (T_{chrg}) to charge the battery fully from the PV panel is calculated using Eq. (5): -

$$E_{pv} = P_{pv} \times t \quad (3)$$

$$E_{stored} = I_{node} \times V_{node} \times t_{node} \quad (4)$$

$$T_{chrg} = E_{stored} / E_{pv} \quad (5)$$

A case study is calculated theoretically from Eqs. (3), (4), and (5). Suppose that the average power of the PV panel is 230 mW ($4.6 \text{ V} \times 50 \text{ mA}$), and it is illuminated from the sunlight for 6 hours per day. Hence, $E_{pv} = 230 \text{ mW} \times 6 \times 3600 = 4968 \text{ Joules}$. The battery voltage is selected as 4.2 V. Thus, $P_{stored} = 4800 \text{ mA} \times 4.2 \text{ V} = 20.16 \text{ W}$. Therefore, the stored energy of the battery can be calculated as $E_{stored} = 20.16 \times 3600 = 72576 \text{ Joules}$. Therefore, T_{chrg} is equal to $72576 / 4968 = 14.6$ days (350 hours). The charging time (T_{chrg}) is a lower than the lifetime (T_B) of the node. Therefore, the proposed photovoltaic energy harvesting system is sustainable for supplying the developed wearable sensor node.

III. HARDWARE ARCHITECTURE OF THE WEARABLE SENSOR NODE

In this work, Fig. 2 shows the hardware architecture of the developed wearable sensor node. The wearable sensor node includes two low-power healthcare sensors: One is a MAX30205 manufactured by Maxim® to measure body temperature, and the second is a heart pulse sensor chosen as SEN-11574 from SparkFun Electronics® for measuring the heartbeats. In addition, a LilyPad Arduino board from Atmel® was used as an ATmega328p microcontroller unit for processing the healthcare sensors data. The hardware architecture is based on BLE technology using an HM-10 module from Texas Instruments®. This module was used for data transmission. As complementary work, a photovoltaic energy harvesting system was implemented to extend the lifetime of the wearable sensor node without replacing the rechargeable battery.

Moreover, an amorphous flexible PV panel (MPT 4.8-75) was used from PowerFilm® with an area of a $7.2 \times 6.0 \text{ cm}^2$. This PV panel can output a maximum voltage of 4.8 V and output a maximum power of 240 mW at 1000 W/m^2 . It is connected to a TP4056 charging controller, and a 18650-lithium ion rechargeable battery with 4800 mAh capacity. This battery supplies 20.16 Wh to the wearable sensor node, and its voltage of 4.2 V. The battery voltage is regulated to 3.3 V using a MCP1700 low dropout (LDO) voltage regulator, because the operating voltage of the microcontroller is 3.3 V. The battery is used to store the harvested energy from the flexible PV panel for long-term operation. In this work, the developed wearable sensor node was tested outdoors with the sunlight, which was the illumination source, and a solar power meter was used to measure the irradiance levels. Table I gives the current consumption and operating voltage of the used electronic components of the developed wearable sensor node.

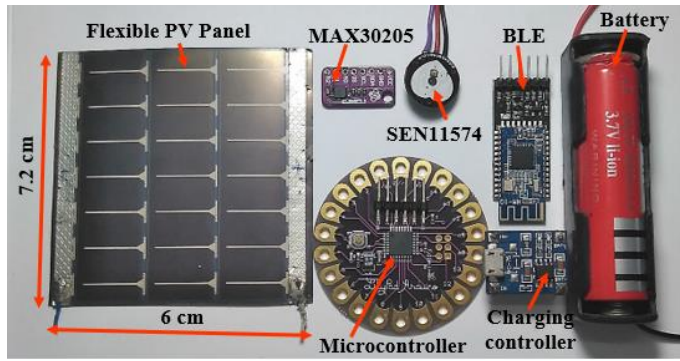

Fig. 2. Hardware architecture of the developed wearable sensor node.

TABLE I
THE PROPOSED ELECTRONIC COMPONENTS IN THE DEVELOPED WEARABLE SENSOR NODE

Components	Model	Voltage (V)	Current (mA)
Temperature Sensor	MAX30205	3.3	1.3
Heart Pulse Sensor	SEN-11574	3.3	3.1
Microcontroller	ATmega328p	3.3	6.1
BLE module	HM-10	3.3	9.15

IV. WEARABLE SENSOR NODE IMPLEMENTATION

Fig. 3 shows the software flowchart of the developed wearable sensor node. There are two modes for the wearable sensor node: the active mode and sleep mode. At first, the microcontroller of the sensor node was programmed to active mode (wake-up) in order to measure and transmit the healthcare data for 15 seconds. Secondly, all sensors were turned off, and then, the BLE module was slept. Thirdly, the microcontroller of the wearable sensor node entered sleep mode for 885 seconds (configured time) to save power. Then, the microcontroller wakes up again to power all sensors and BLE module for 15 seconds, and so on. Finally, the previous steps were continuously repeated in a loop. The software algorithm of the sensor node was implemented using the C language. The mobile phone received the healthcare data from the wearable sensor node and monitored the measurements on the HMBLE Terminal android application. Due to the development of the software flowchart, the sensor node's lifetime was extended to 246 hours.

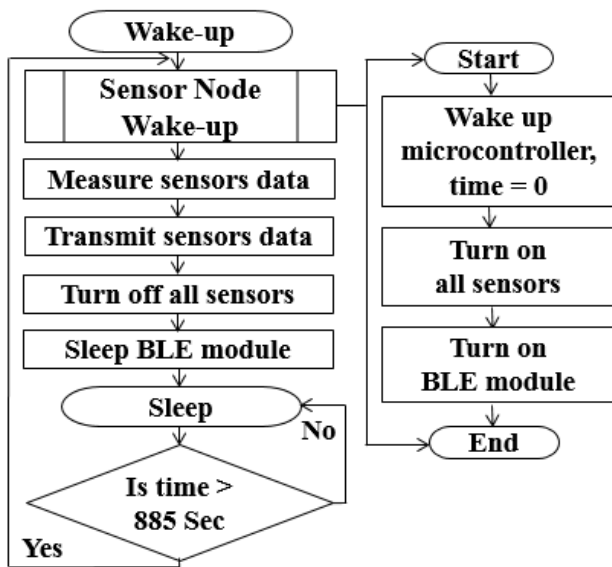

Fig. 3. The software flowchart of the developed wearable sensor node.

V. EXPERIMENTAL RESULTS

Experimentally, at 1000 W/m², the used flexible PV panel was tested outdoors with the sun irradiance source in order to validate its I-V and P-V characteristic curves. Fig. 4 shows the I-V and P-V characteristic curves of the used flexible photovoltaic panel. It is clear that the PV panel's maximum current value was 49.5 mA at 4.6 V, with a maximum power value of 207 mW at 4.6 V. In addition, Table II shows the practical power consumption of the wearable sensor node according to two different modes. In stage 1, the wearable sensor node is configured in active mode. Thus, all the used components of the node draw 19.6 mA of total current and consume 64.68 mW of power. At stage 2, the wearable sensor node is put in sleep mode for 14 minutes and 45 seconds and consumes 3.96 mW. Also, the average current consumption of the wearable sensor node during sleep mode is experimentally measured at 1.2 mA. According to the experimental measurements, the average power consumption (P_{avg}) of the sensor node is calculated using Eq. (6). Therefore, the average power consumption is equal to 4.97 mW in one hour. The measurements were experimentally taken using a YF-78 multimeter. Fig.5 demonstrates the setup for the developed wearable sensor node with photovoltaic energy harvesting. During setup, the flexible PV panel was placed on the wrist of a human hand. In the front area of the setup, the sensors (SEN11574, MAX30205), and BLE were soldered on a LilyPad Arduino board. The total area of the LilyPad board was (5.0 cm × 5.0 cm). The LilyPad was sewed on a suitable textile, and the charging controller was placed inside this textile.

$$P_{avg} = [(P_{Active} \times T_{Active}) + (P_{Sleep} \times T_{Sleep})] / T \tag{6}$$

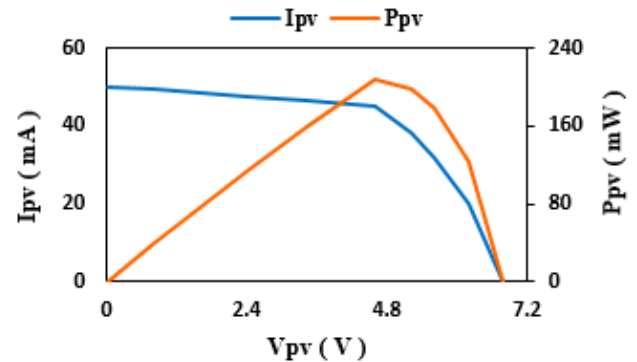

Fig.4. I-V and P-V characteristic curves of the flexible photovoltaic panel at 1000 W/m²

TABLE II
THE POWER CONSUMPTION OF THE NODE AT TWO STAGES

Stage	Mode	Current (mA)	Power (mW)	Time (s)
1	Active	19.6	64.68	15
2	Sleep	1.2	3.96	885

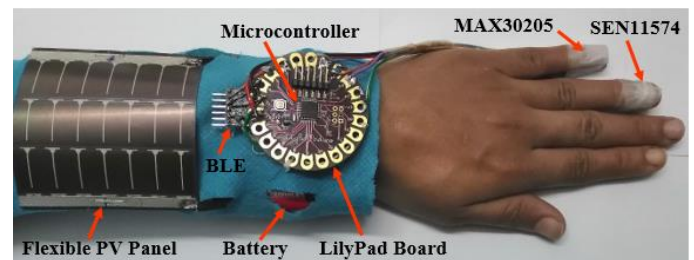
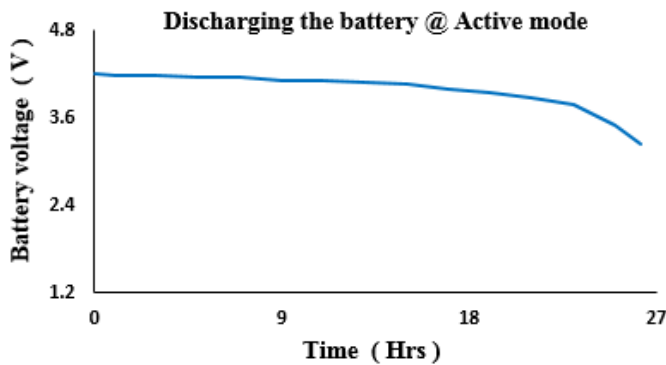
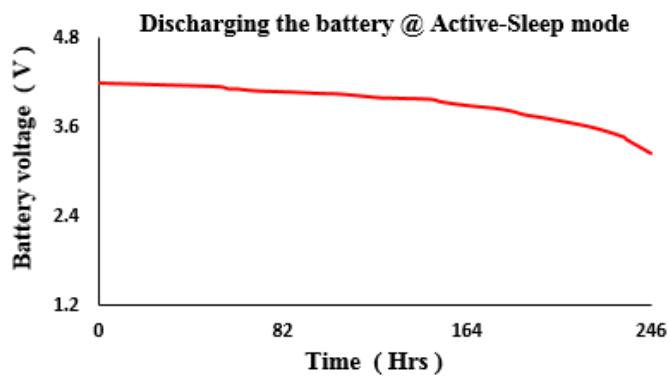

Fig.5. The setup for the developed wearable sensor node.

Fig. 6 illustrates the discharging curves of the battery for the sensor node in the active mode and active-sleep mode. Therefore, in active mode, the voltage of the battery decreases from 4.2 V to 3.3 V, and the node's lifetime reaches 26.5 hours. In active-sleep mode, the battery takes about 246 hours to discharge from 4.2 to 3.3 V. Fig. 7 demonstrates the voltage monitoring from the battery over 24 hours. The voltage is continuously monitored every second using an Arduino board. Then, the voltage readings are plotted in an Excel file. The monitoring operation was started in 12:00 am on 27-January-2019, and terminated at 12:00 am on 28-January-2019. In this experiment, the node is configured in the active-sleep mode, and is connected to the battery with the PV harvesting system, which is placed in the night for 18 hours, and is directed to the sunlight for 6 hours. It is clear that the battery voltage is decreased in the night, and is increased during the sunlight. Therefore, the battery voltage is remained between 3.87 V to 4 V. Moreover, the PV harvesting system with the battery provides sufficient energy to supply the node. Finally, the experimental results illustrate that the system can sustainably work.



(a)



(b)

Fig. 6. Discharging curves of the battery: (a) at active mode; (b) at active-sleep mode

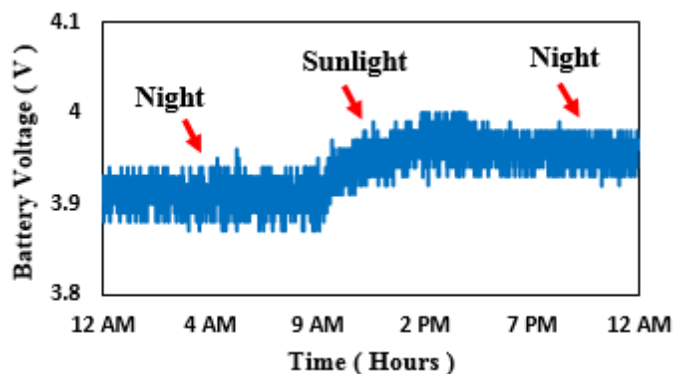

Fig. 7. The 24 hour operation time of the battery voltage monitoring

Fig. 8 illustrates the heartbeats monitoring from the node for an adult human over time. The heartbeats are changed under different physical conditions of a human body. The heartbeat values continuously change for 30 seconds. This figure shows that the minimum value of the heartbeat is 64 bpm. This value means that the human is in a relaxation status. Also, the maximum value of the heartbeat is 84 bpm. This value means a great effort of a human activity. For an adult human, the normal rate of heartbeats is 72 bpm [20]. The heartbeats monitoring operation is executed through the HMBLE Terminal android mobile application. The heartbeat readings are stored in an Excel file. Fig. 9 illustrates the healthcare data screenshot of the mobile application. This application is downloaded from the Play Store website. This application displays the body temperature and heartbeat values that inform doctors about the healthcare status of a human. The healthcare vital data of a human is continuously updated. It is clear that the monitored values within the normal range of the body temperature and heartbeats of a human.

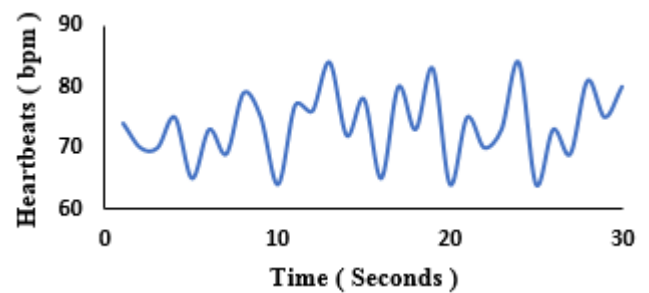

Fig. 8. Heartbeats monitoring from the node over time



Fig. 9. Healthcare data screenshot of the mobile application

VI. DISCUSSION

Table III shows comparisons between different wearable sensor nodes with photovoltaic energy harvesting systems. In this work, the sensor node consumes 4.97 mW, which is lower than that in the literature [16-19]. Further, without photovoltaic energy harvesting, the lifetime of the sensor node is 246 hours, which is higher than the lifetimes in [16-19]. In addition, the node lifetime is sustainable with photovoltaic energy. The developed node has two sensors, but the nodes in [17,18] only contain one sensor. The used energy source area of (7.2 cm × 6.0 cm) is smaller than in [16,18]. The used BLE wireless technology is higher range than the ranges in [16,17].

TABLE III
COMPARISONS OF WEARABLE SENSOR NODES WITH PHOTOVOLTAIC ENERGY HARVESTING SYSTEMS

Reference	Sensors	Wireless technology	Energy storage	Lifetime of node (Hours)	Power consumption of node (mW)	Energy source	Energy source area (cm ²)
[16]	PPG Sensor and ECG Sensor	HC-06 2.4 GHz 9 m	Battery 3 V 500 mAh	41	41.25	Flexible solar panel	19 × 4.0
[17]	ECG Sensor	CC2541 2.4 GHz 60 m	Battery 3 V 310 mAh	31	29.74	_____	_____
[18]	Temperature Sensor	XBee 2.4 GHz 100 m	Battery 2.5 V 1500 mAh	40	91.41	Solar panel	11.43 × 6.68
[19]	PPG Sensor and accelerometer	_____	Super-capacitor 5.4 V 12.5 F	12	28.98	Flexible solar panel	7.2 × 6.0
This work	Heart pulse Sensor and Body Temperature Sensor	BLE 2.4 GHz 100 m	Rechargeable battery 4.2 V 4800 mAh	246	4.97	Flexible Photovoltaic panel	7.2 × 6.0

VII. CONCLUSION

This paper presents a wearable sensor node successfully implemented in medical applications. This node is powered by a sustainable photovoltaic (PV) energy harvesting system. In addition, a software algorithm is developed to save the power consumption of the node. This algorithm saves the power using sleep commands of the microcontroller, and BLE module. In addition, the algorithm has commands to switch off the sensors of the node during the sleep mode. Therefore, the total power consumption of the sensor node is reduced from 64.68 to 4.97 mW. This reduction extends the working duration of the node from 26.5 to 246 hours without photovoltaic energy. The healthcare data is also continuously visualized on the HMBLE Terminal android application, and the sensor node is attached to a human body. In the future, multiple sensors can be connected with a wearable sensor node. One could also focus on a hybrid energy harvesting system to increase the battery lifetime of the developed wearable sensor node.

REFERENCES

- [1] Y. H. Kwak, W. Kim, et al, "Flexible heartbeat sensor for wearable device," *Biosensors and Bioelectronics*, vol.94, 2017, pp. 250–255.
- [2] C. Seeger, K. Van Laerhoven, A. Buchmann, "Myhealthassistant: An event-driven middleware for multiple medical applications on a smartphone-mediated body sensor network," *IEEE journal of biomedical and health informatics*, 2015, 19, (2), pp. 752–760.
- [3] Taiyang Wu, Fan Wu, Jean-Michel Redoute, et al, "An Autonomous Wireless Body Area Network Implementation towards IoT Connected," *IEEE access*, vol.5, 2017, pp. 11413–11422.
- [4] Haojun Huang, Jianguo Zhou, Wei Li, Juanbao Zhang, Xu Zhang, Guolin Hou "Wearable indoor localization approach in internet of things," *IET Networks*, vol.5, 2016, pp. 122–126.
- [5] T. Wu, M. S. Arefin, J.-M. Redoute, et al, "A solar energy harvester with an improved MPPT circuit for wearable IoT," *Int. Conf. IEEE. Body Area Networks (Bodynets)*, Turin, Italy, 2016, pp. 166–170.
- [6] T. Wu, M. S. Arefin, D. Shamilovitz, et al, "A flexible and wearable energy harvester with an efficient and fast converging analog MPPT," *Conf. IEEE. Biomedical Circuits and Systems (BioCAS)*, Shanghai, China, 2016, pp. 336–339.
- [7] Yang Kuang, Tingwen Ruan, et al, "Meiling Zhu, Energy harvesting during human walking to power a wireless sensor node," *Sens. Actuators A: Phys*, vol.254, 2017, pp. 69–77.
- [8] A. Dionisi, D. Marioli, E. Sardini, et al, "Autonomous wearable system for vital signs measurement with energy-harvesting module," *IEEE Transactions on Instrumentation and Measurement*, vol.65, 2016, pp. 1423–1434.
- [9] Jiasha Elizabeth Shaji, Bibin Varghese, et al, "A Health Care Monitoring System with Wireless Body Area Network Using IoT," *International Journal of Recent Trends Engineering & Research*, vol.3, 2017, pp. 112–117.
- [10] Luis M. Borges, Raul Chávez-Santiago, et al, "Radio-frequency energy harvesting for wearable sensors," *IET Healthcare Technology Letters*, vol.2, 2015, pp. 22–27.
- [11] A. B. Amar, A. B. Kouki, et al, "Power approaches for implantable medical devices," *Sensors*, vol.15, 2015, pp. 28889–28914.
- [12] M. A. Hannan, S. Mutashar, S. A. Samad, et al, "Energy harvesting for the implantable biomedical devices: issues and challenges," *Biomedical engineering online*, vol.13, 2014, pp.79.
- [13] B. Yang, K.-S. Yun, "Piezoelectric shell structures as wearable energy harvesters for effective power generation at low- frequency movement," *Sens. Actuators A: Phys*, vol.188, 2012, pp. 427– 433.
- [14] Z.G. Wan, Y. K. Tan, et al, "Review on energy harvesting and energy management for sustainable wireless sensor networks," *Int. Conf. IEEE. Communication Technology (ICCT)*, 2011, pp. 362–367.

- [15] S. Stoecklin, A. Yousaf, et al, "Efficient wireless powering of biomedical sensor systems for multichannel brain implants," *IEEE Transactions on Instrumentation and Measurement*, vol.65, 2016, pp. 754–764.
- [16] Thang Viet Tran, Wan-Young Chung, "High- Efficient Energy Harvester with Flexible solar panel for a wearable sensor device," *IEEE Sensors Journal*, vol.16, 2016, pp. 9021–9028.
- [17] M. Dai, X. Xiao, et al, "A low-power and miniaturized electrocardiograph data collection system with smart textile electrodes for monitoring of cardiac function," *Australasian. Phys. Eng. Sci. Med*, vol.39, 2016, pp. 1029–1040.
- [18] J. C. Lim, M. Driberg, et al, "A simple solar energy harvester for wireless sensor networks," *Int. Conf. Intelligent & Advanced Systems (ICIAS)*, 2016.
- [19] T. Wu, M. S. Arefin, J.-M. Redoute, et al, "Flexible wearable sensor nodes with solar energy harvesting," *Int. Conf. IEEE. Engineering in Medicine and Biology (EMBC)*, Seogwipo, South Korea, 2017, pp. 3273–3276.
- [20] Gaurav Kumar, Km. Shilpa Maurya, et al, "Design and development of heart rate and temperature measuring device using MATLAB," *International Journal of Advanced Research in Electrical, Electronics, and Instrumentation Engineering*, vol.6, 2017, pp. 3366–3372.