



for their underground use, provided that some additional conditions are fulfilled.

### III. MEASUREMENT METHODOLOGY

The above mentioned systems were used to perform measurement experiments, used to assess some basic parameters, such as: throughput, delays or range.

#### A. Test environment

Tests were performed underground at a copper mine in Lubin, at a depth of around 600m below ground surface. Two characteristic areas for the mine site have been chosen: one straight corridor with a length of around 700m as well as a grid of corridors, covering around 300m x 100m area.

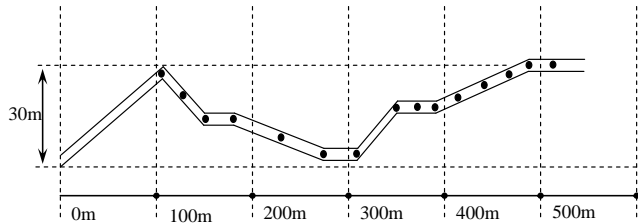

Fig. 1. Vertical cross-section of the straight corridor.

The tunnels forming the grid were generally flat and level, whilst the long straight corridor had risen and falling sections along its length. The rough cross-section of the tunnel along with location of the measurement points is shown by Fig. 1, where the indicated lengths are as measured along the corridor floor.

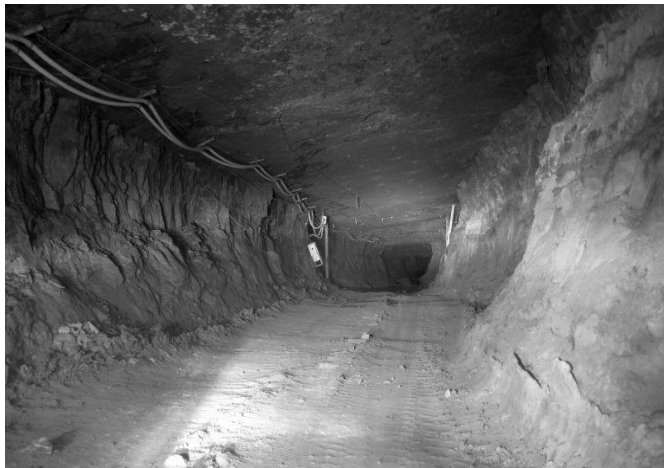

Fig. 2. Long straight corridor.

The height of the straight corridor was around 4m whilst the width was around 5m. The grid corridors were a little lower, at around 3m, having the same width as the straight tunnel. Pictures of these corridors have been included below in Fig. 2 and Fig. 3.

#### B. Measurement system

Because of the damp soil (in many places there were puddles of water and deep mud) the measurement configuration and methodology had to be modified to match

these conditions. In order to have comparable results, all of the systems had to be evaluated in the same way and using the same tools. Furthermore, the need for external power for both the assessed and measurement devices determined that a point-to-point architecture should be used. Figure 4 shows the test configuration.

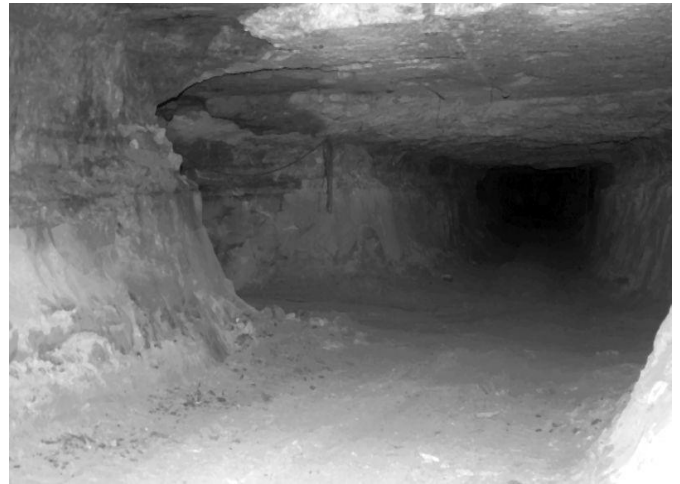

Fig. 3. Corridors in the grid structure.

During tests three portable computers (Celeron 1.86GHz, 1GB RAM and CentOS operating system) have been used. Depending on the assessed system, the TX station has been chosen to be the base station (WiMax systems) or the access point (WLAN systems), where the receiver was either the user terminal (WiMax) or a client adapter card (WLAN). The TX station was placed on a fixed mast, at a height of around 3m and around 0,5m from the wall. The RX station was moved along the corridor - being placed on top of a car thus around the center of the tunnel, at a height of around 2m. Measurement units for WiMax 1,5GHz system are shown in figure 5 and 6.

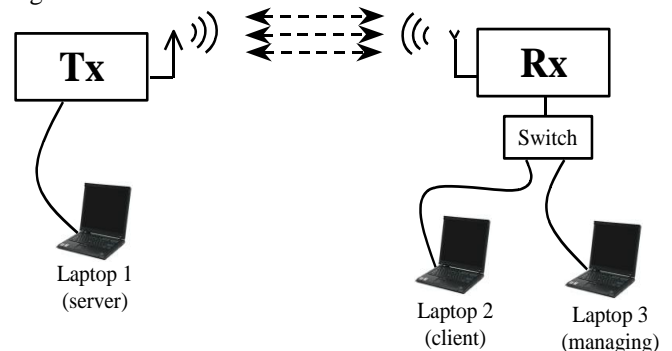

Fig. 4. Vertical cross-section of the straight corridor.

#### C. Test methodology

Assessment was performed using three software applications: rude/crude, iperf and ping. The first two programs were used for throughput measurements at each of the test spots, whilst ping was used to measure packet delays. During assessments in the straight corridor has been used a special script for throughput measurements, written according to RFC recommendations and using the rude/crude application. During assessment, each measurement would last

30s. The general operating principle of this script consists of increasing or decreasing packet generation speed, based on packet loss.



Fig. 5. Tx unit for WiMax 1,5GHz system



Fig. 6. Rx unit for WiMax 1,5GHz system mounted on car

Throughput measurements in the grid corridors were performed using the Iperf program. Considering that in this test environment significant throughput variations were observed, whilst the script would not retest a certain packet TX speed after it was rejected, the test results were underestimated and therefore it has been decided to use Iperf, setting the measurement time to 60s. Throughput measurements were recorded every second, where these sixty measurements were then used to calculate the final throughput value.

#### IV. MEASUREMENT RESULTS

The available systems have been tested in both the straight

corridor and the grid tunnel environments, presenting the results for both below.

##### A. Long straight mine corridor

Long straight corridors are typical for this test environment. These are the main communication ducts used by excavation vehicles. In order to assess range and select the measurement points (as well as the density of their distribution) a preliminary assessment using ping has been performed (to check the TX/RX connection). This test was performed using WiMax 1.5GHz (Table I), based on its parameters, which seemed most promising to achieve the highest range.

TABLE III  
RESULTS OF THROUGHPUT MEASUREMENTS [MBIT/S]

Distance [m]	WiMax 1.5GHz	WiMax 3.5GHz	WLAN 0.9GHz
50	-	24.9	30.4
100	11.555	24.9	30.8
130	11.85	24.6	30.1
150	11.85	24.9	28.7
180	11.85	24.9	28.3
230	11.642	24.9	24.5
280	11.85	18.8	22
320	8.249	4.8	15
350	7.758	5.4	2.7
370	5.166	2.7	1.7
390	7.5	no connection	no connection
420	3.87	no connection	no connection
450	1.194	no connection	no connection
470	1.649	no connection	no connection
490	1.491	no connection	no connection
510	no connection	no connection	no connection

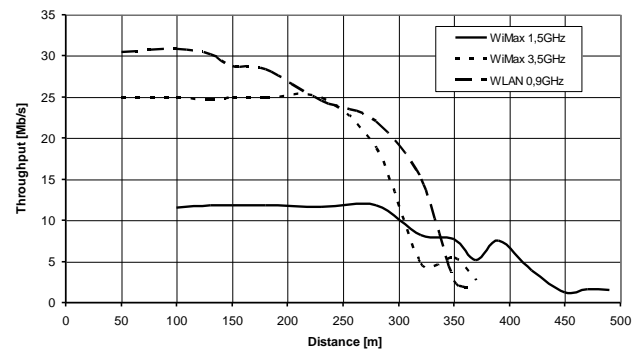

Fig. 7. Throughput as a function of distance

This test gave a rough estimate of the range of around 500m. The distribution density of the test points was verified experimentally when performing the tests (we assumed a higher density of these points when observing more significant variation of measured throughput), thus it is quite low in the beginning section of the corridor. Furthermore, conditions at certain points of the tunnel did not allow for performance of tests (deep and wide puddles, steep inclines with soft soil), because of the inability to stop the vehicle at these points. During tests the throughput (rude/crude script), delays (ping)

and received signal power (as reported by the device application) have been measured. Detailed results are presented in Table III and Fig. 7. Considering that test results for WLAN 2.4GHz differ significantly from the other systems and that showing them together would make the data unclear, it is presented separately (Table IV, Fig. 8).

TABLE IV  
RESULTS OF THROUGHPUT MEASUREMENTS [MBIT/S] FOR WLAN  
2.4GHz

Distance [m]	Throughput [Mb/s]
0	88.03
20	140.62
30	140.60
40	135.22
50	135.29
60	113.09
70	144.90
80	107.70
90	129.20
100	133.56
110	107.50
120	52.46
130	67.30
140	42.65
150	43.58
160	52.80
170	30.78
190	no connection

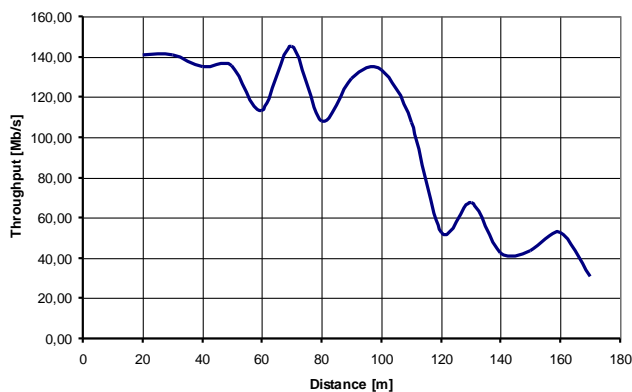

Fig. 8. Throughput as a function of distance for WLAN 2.4GHz

Based on the experimental results, the best performance was achieved using WiMax 1.5GHz. The priority of our measurements was to achieve the highest possible range at certain minimum throughput, and whilst systems WiMax 3.5GHz and WLAN 0.9GHz allowed for higher throughput, after reaching around 350m (the beginning of another incline – Fig. 1) we lost connection. Systems WiMax 1.5GHz, WiMax 3.5GHz and WLAN 0.9GHz all have comparable TX power. As expected, the highest range was achieved using the first system, because of a lower TX frequency compared to the second system (lower influence of scattering from uneven surface) and different TX protocol compared to the third

system. It seems that the achieved range in these conditions of around 500 meters is quite promising for potential use of such systems in underground mines. The WLAN 2.4GHz system had significantly lower range compared to the remaining ones. This can be attributed to its lower TX power as well as lower TX and RX antenna gain. Even though this system allowed for very high transmission speed, our key objective was to achieve the highest range. The speed of 1Mb/s (WiMax 1.5GHz at a distance of around 500m) allows for successful transmission for a variety of services, e.g. voice transmissions. As one can easily notice, increase of the distance to the transmitter results in decrease of throughput. This matches theory, as increase of distance leads to a lower received signal strength, which in turn requires change of modulation, to one better suited to cope with interference, but which provides lower throughput.

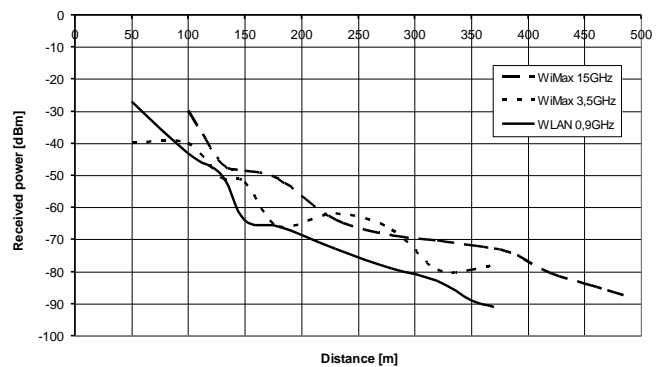

Fig. 9. Received power as a function of distance

Results of measurements of received power are shown in figure 9 (power was measured simultaneously with the throughput and delay by dedicated application for each system). As it can be noticed the received power for WiMax 1.5GHz at distance about 370m (border of range for WiMax 3.5GHz and WLAN 0.9GHz) is higher than for the other systems so the transmission is possible. Interesting phenomenon was that WiMax 1.5GHz waves were propagated better than waves of the WLAN system operating in 0.9GHz band (shown in reference [3]). The waves with lower frequency (longer wave length) theoretically could propagate better in this environment than waves with higher frequency (more resistant to scattering). In this case better waves propagation with higher frequency (1.5GHz relative to 0.9) results from properties of system (WiMax relative to WLAN). Transmit power for each system was set on maximum (see point II).

Delay measurement results (Fig. 10) show that it is fairly constant when moving along the corridor. It should be noted that the measurement was performed using the "ping" command, which measures signal delay from the transmitter to the receiver and back to the transmitter. Lowest delay was achieved for the WLAN 0.9 GHz systems, which could be attributed to a different transmission protocol. However, the achieved results in the area of around 30ms should not prevent implementation of various services, like real-time voice transmission.

**B. Grid corridors**

The grid corridor structure as presented in Fig. 11 is another characteristic arrangement found in underground mine excavations. The arrangement of corridors is related to the method used for ore excavation. The total distance between the TX point and point 19 is 311m, whilst the distance between the parallel transversal corridors is around 50m. The first measurements were performed between the transmitter and point 19, which provided a line of sight connection. The power indicator of the terminal at the end of the corridor displayed around 4dB (for WiMax systems) and around 30dB (WLAN 0.9GHz) lower value compared to the value measured near the base station, however this did not affect the system throughput. Considering this, the throughput values achieved along this corridor were basically the same at all points as in point 19 (Table V).

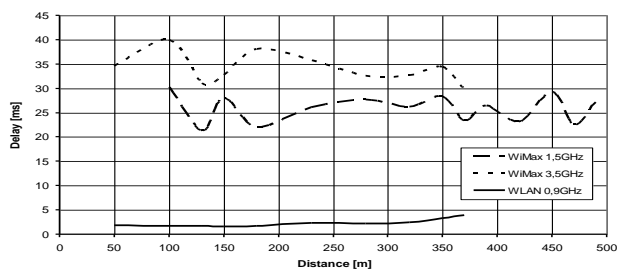

Fig. 10. Delay as a function of distance

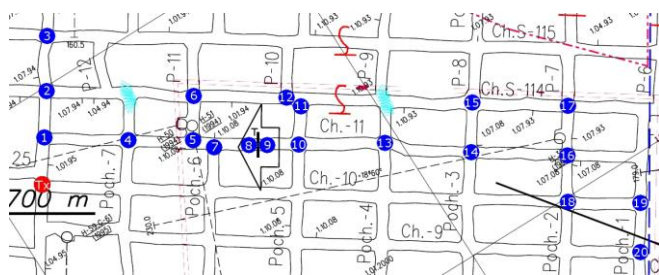

Fig. 11. Fragment of the corridor grid with indication of measurement points

The second phase of tests consisted of measurements at corridor intersections - assuming the arrangement of test points shown in Fig. 11. Considering a rubber curtain (used to control air circulation in the mine shown in Fig. 12) between points 8 and 9, it can be noticed that a higher density of measurement points has been used in this area.

As mentioned earlier, the systems achieved the maximum throughput even at the highest distance between the TX point and point 19. However as it was moved to the sides, a drop in throughput, down to total loss of connection was experienced. One should note points 14, 15 and 16, where only WiMax 1.5GHz allowed for transmission - this can be attributed to electromagnetic wave propagation and its reflection from the tunnel walls. The operating frequency of WiMax 1.5GHz is much lower than of WiMax 3.5GHz, thus the higher wavelength. As expected, the longer wavelength is much less prone to scattering on the uneven surfaces. On the other hand,

in case of WLAN 0.9GHz, the lack of range at these points was probably caused by the characteristics of the transmission protocol and the unfavorable link budget, rather than scattering of waves.



Fig. 12. Rubber curtain to control air circulation

TABLE V  
RESULTS OF THROUGHPUT MEASUREMENTS [Mb/S]

Measurement point	WiMax 1.5GHz	WiMax 3.5GHz	WLAN 0.9GHz
1	11.1	20.9	22.1
2	11.1	21.4	19.9
3	11.1	21.4	21.8
4	11.1	19.6	7.6
5	1.38	no connect.	1.63
6	-	-	-
7	1.24	12.7	1.7
8	5.75	2.4	7.8
9	3.82	no connect.	0.592
10	7.11	14.6	5.34
11	11.1	no connect.	1.29
12	no connect.	no connect.	no connect.
13	5.04	6	no connect.
14	7.52	no connect.	0.765
15	9.9	no connect.	no connect.
16	3.82	no connect.	no connect.
17	no connect.	no connect.	no connect.
18	11.1	21.6	23.2
19	11	20.1	22.8
20	1	12.3	-

Received power for each system measured in each point is shown in Fig. 14. As mentioned in point IVA, the power was measured by dedicated application so the result of measurement was obtained only in points where there was the connection between systems units (measurement could be realized). In points where it was unable to obtain the measurement the received power was below the receiver's sensitivity.

Delay measurements lead to similar conclusions as in the earlier straight corridor. The variation of delays at the different measurement points is very small. WiMax systems have significantly higher delays than WLAN system, which relates

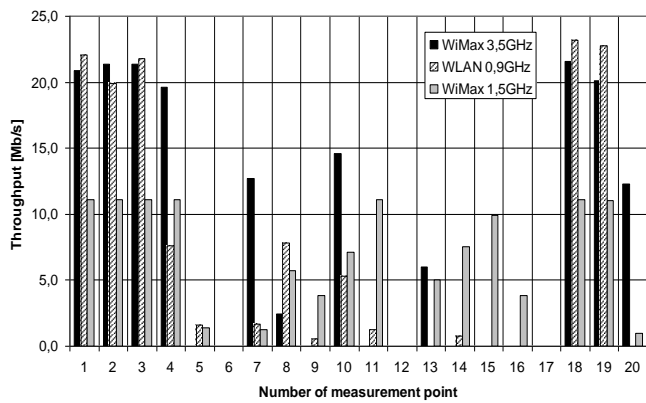

Fig. 13. Throughput at each of the measurement points

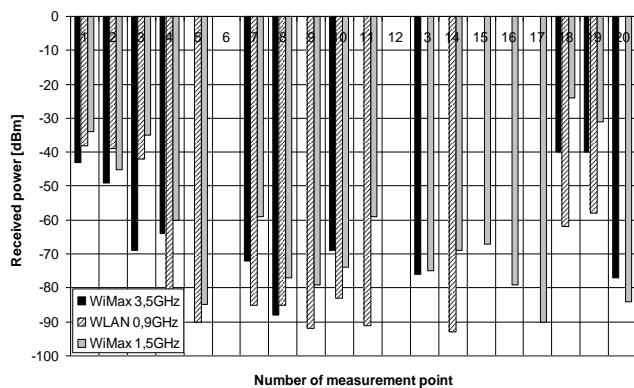

Fig. 14. Received power at each of the measurement points

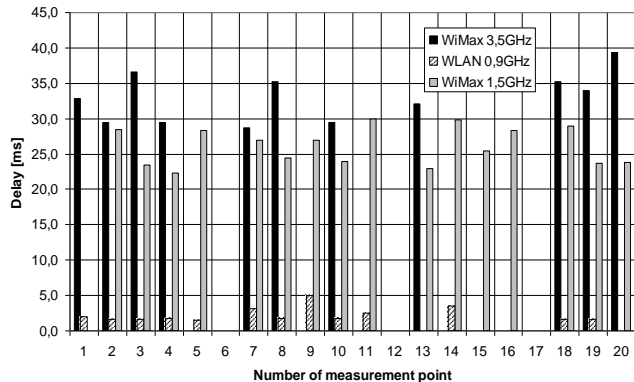

Fig. 15. Delay at each of the measurement points

to their operating principle and the applied transmission protocol. The details pertaining to delay values at the individual test point are given in Fig.15.

## V. SUMMARY

Test results prove that wireless systems operating using the above mentioned standards can be successfully used in environments differing from ones for which they have been originally designed. In view of range, the best system is one using WiMax air interface in 1,5GHz transmission band – it allowed for straight-line connection of around 500m, whilst the remaining systems failed to connect after around 370m. This system also proved best in the grid corridor arrangement. Excluding a few exceptions it allowed for communication throughout the entire test area. Even though the throughput for this system dropped at some areas to around 1Mb/s, this is still a sufficient speed to implement most of the packet network services. The delays of around 30ms are higher than in typical wired networks, however still insignificant to the quality of the foreseen services.

Wireless systems based on the configuration of WiMax 1.5GHz could be successfully used to assure communications at areas where installation of radiating cables is too expensive or where it would prove insufficient because of the limited throughput. WiMax based systems could be used as a backbone for voice, video or telemetric data transmissions, whilst at the same time using WLAN as the access system. The research confirmed that WiMax systems can be used in underground mine environments further and provides an optimistic outlook for further works related to the development and implementation of such systems in this environment.

## ACKNOWLEDGMENT

The authors of this paper would like to thank the management of copper mining KGHM Lubin Główny for allowing us to conduct this research as well as the individual mine employees for their invaluable help during our research.

## REFERENCES

- [1] Miśkiewicz K., Wojacek A.: New solutions of radiocommunication systems for underground mines, (in Polish), *Zeszyty Naukowe Politechniki Śląskiej* 2006.
- [2] Benson, F.A. Cudd, P.A. Tealby, J.M.: Leakage from coaxial cables, *IEE Proceedings-A, Vol. 139. No. 6, November 1992*.
- [3] Staniec K., Radio waves propagation in realistic mine environment, (in Polish), *Przegląd Telekomunikacyjny/Wiadomości Telekomunikacyjne*, 06/2009