

Reconfigurable Antennas: the State of the Art

Yevhen Yashchynshyn

Abstract—The paper provides an overview of the state of the art in the area of reconfigurable antennas. This emerging area has been rapidly developing in the recent years. This article brings a comprehensive summary of the high quality applied and fundamental research contributions in the above-mentioned field. A broad spectrum of topics is covered, reflecting the areas in which Institute of Radioelectronics's expertise is recognized worldwide.

Keywords—Antenna arrays, reconfigurable antennas, semiconductor devices, MEMS switches, surface PIN diodes.

I. INTRODUCTION

MODERN wireless systems employ multifunction broadband subsystems to support multiple frequency bands. This is connected with increased technical requirements for some parts of the system, e.g. filters and antennas with adaptable frequency behaviour. Availability of multi-mode, multi-band, and multi-standard devices makes the simplification of RF front ends possible. For example, adaptive filters are realizable with the use of a bank of switchable fixed frequency filters for different frequency bands [19]. Instead of having multiple antennas switched into multiple transceivers covering different frequency ranges, a single multi-band tuneable antenna set would provide product size and complexity reduction. Tuneable antenna technology can be fully utilized for next-generation wireless devices.

On the other hand, as more wireless services are getting more common, availability of the radio spectrum is decreasing. Moreover, different countries have their own spectrum allocations. Technology which tries to resolve these problems is the Cognitive Radio. It adds computational intelligence to a system to provide dynamic services. Hence, it is not practical to dedicate one antenna to each service: some of the services are required all the time, while others may be required periodically. In most cases, systems would need an automatic switching between these different modes, bands, polarizations, etc. Many services mean many antennas, and many standards mean more antennas in a conventional case of multiple antennas. In order to reduce antenna dimensions and costs, and to improve performance characteristics, it is desirable to combine multiple functions into a single antenna system.

Providing additional levels of functionality for a wireless system is limited if antenna characteristics are fixed. Reconfigurable antennas can help avoid these restrictions and open new horizons for high functionality of wireless systems. Using frequency-reconfigurable antennas as an alternative for

multiband or wideband antennas is one of the examples of an effective solution.

To satisfy multi-mission functionalities, a single aperture requires an antenna array that can be quickly reconfigured to operate efficiently, e.g. at various frequencies. Contrary, reconfigurable aperture reduces the complexity of an antenna system operating on a desired frequency bands, with the control over antenna gain and beam pointing direction or shape.

Reconfigurable antennas have existed for many years. Reconfiguration of antenna can be achieved through an intentional dynamic redistribution of currents of an antenna's aperture. These changes are enabled through various mechanisms such as switching, material tuning, or structural modifications. It can be seen that reconfiguration does not include the use of phase shifters and matching circuits that do not interact directly with the mechanism of radiation. Increased complexity is a cost of enhanced performances. From a practical perspective, additional feature of reconfigurable antennas should therefore countervail the cost and complexity of reconfiguration [2].

Many solutions of reconfigurable antennas have been described in the literature, and they have been successfully applied in telecommunication systems, e.g. satellite communication [30]. With the expanding demands on wireless systems one can look forward to new antenna reconfigurability specification, e.g. at multiple frequencies with varying bandwidth, polarization and radiation characteristics.

Reconfigurable antennas come in a large variety of shapes and forms. They are typically described by some categories, including reconfigurable radiation pattern, and/or polarization, reconfigurable frequency, and/or bandwidth.

There are four main mechanisms of changing the antenna's parameters:

- mechanical/electromechanical, e.g. by using MEMS switches,
- electronic, e.g. by using PIN diodes,
- optical, e.g. by using photosensitive layer,
- electrical/magnetic, e.g. by using special substrate media such as controllable materials (ferroelectrics, liquid crystal and ferrite).

Combination of the aforementioned mechanisms is also very useful.

Considering the properties of a base design, reconfigurable antennas can be classified according to the continuity of reconfiguration, which is defined by the reconfiguration mechanism:

- continuous reconfiguration within a range of parameters,
- discrete - a finite number of reconfigured states.

In this paper, two important characteristic parameters of a reconfigurable antenna, an operating frequency and radiation pattern, have been considered by means of electrical,

electronic and electromechanical mechanism of continuous and discrete reconfiguration.

The paper is organized as follows. Section II presents the continuously reconfigurable antennas. The electronic and mechanic ways, and reconfiguration mechanisms by material changes are described. The discretely reconfigurable antennas based on the separated switches, e.g. MEMS switches, and temporarily created switches are presents in Section III.

II. CONTINUOUSLY RECONFIGURABLE OR TUNEABLE ANTENNAS

There are numerous approaches to continuous reconfiguration of operating frequency and radiation pattern of antennas.

A. Electronic Reconfiguration

The electronic way of changing antenna's parameters is most frequently utilized, e.g., by varactors. Varactor impedance is controlled by electrical voltage. Parasitic antenna array [38] is an example of a simple microstrip array, which uses two varactors to reconfigure the radiation pattern. This antenna consists of three parallel strips printed on the grounded substrate. The center strip is a driven element and strips on either side are the parasitic ones. These parasitic elements can be lengthened or shortened with respect to the driven element. Their effective electrical lengths can be continuously tuned by electrical controlling of the value of the varactors capacity. This causes the reconfiguration of the radiation pattern and small changes of the input impedance.

Another example of using the varactors for tuning the antennas' parameters is in [4]. This dual-band frequency reconfigurable antenna utilizes two varactors which tune two matched impedance bands of a slot antenna. By adjusting the bias of the two varactors, the antenna is capable of tuning each band independently or simultaneously. Furthermore, in contrast to the previous case, it shows similar radiation patterns and polarization at both bands and over tuning.

B. Reconfiguration Mechanisms by Material Changes

One of the most comprehensive antenna arrays used in communication and radars is the phased array. The complexity of the phased array increases rapidly with its size. The main objects which contribute to the significant cost of the phased array are the phase shifters. Beside the possibility of reducing the phase shifters cost, it is possible to design the tunable antennas without exploiting these very expensive elements. This type of antenna is known as integrated antenna. For tunability, the integrated substrate of antenna has to be controlled.

Advances in several areas of materials science have led to a variety of new materials with strong potential applications to microwave and millimeter-wave components. A number of review papers [29, 12, 31, 15, 25] have appeared recently, covering different aspects of tunable ferroelectric materials and their applications.

High tunability and low dielectric losses are the only desired properties of material which can be applied in tunable micro- and mm-wave devices. Despite the enormous effort

made to reduce the cost of tunable devices, the desired progress has not been achieved yet. However, as demonstrated recently, a number of the device configurations are a promising solution to inexpensive controlling.

Ferroelectric materials having a dielectric constant that can be modulated at high frequencies by electric bias perpendicular to the direction of signal propagation is very attractive, and can be used to develop a new family of devices operating in the microwave and mm-wave range. Ferroelectric materials are in many ways dual to ferromagnetic materials. However, they have a number of advantages over the ones controlled by magnetic field. In ferroelectrics, the driven energy required to change the property of the material goes primarily to changing the stored electrostatic energy and is not dissipated in the material. As a consequence, less power is required to control the property of the material. Ferroelectric also allows for faster tuning compared to ferromagnetic, they have smaller and lighter structure, and allow for high power capability. There are some unsolved problems which are needed to be worked out, e.g. permittivity, tunability and losses of ferroelectrics and the interaction between them. This in turn enables to figure out the desired properties of tunable ferroelectrics and point out their principal applications.

As mentioned before, the main attraction of ferroelectric materials is the dependence between permittivity ε and applied bias electric field E_0 , which is commonly described by the *relative tunability* n_r , defined as a relative change of dielectric constant with respect to DC bias voltage

$$n_r = \frac{\varepsilon_{r,\max} - \varepsilon_{r,\min}}{\varepsilon_{r,\max}} = 1 - \frac{1}{n}. \quad (1)$$

Formula (1) presents a new form of the tunability definition which differs from the one well known in the literature, e.g. [25]. The reason is that conventionally, dielectric permittivity of typical ferroelectric materials decreases with the increase of electric field. However, some new materials, e.g. ceramic-composite [35] demonstrate permittivity increase with the field increases.

In the first case, maximal permittivity is the permittivity at zero electric field $\varepsilon_{r,\max} = \varepsilon(0)$ while in the second permittivity at non-zero electric field has higher value $\varepsilon_{r,\max} = \varepsilon(E_0)$.

Dielectric loss in ferroelectrics is determined by the loss tangent $\tan \delta$, as in case of common microwave dielectrics. Ferroelectrics also exhibit temperature dependence of the permittivity. Because the correlation between tunability and the losses optimal choice between these two parameters for the best performance can be estimated by Communication Quality Factor (K):

$$K = \frac{(n-1)^2}{n \cdot \tan \delta(U_{\min}) \cdot \tan \delta(U_{\max})}, \quad (2)$$

where U_{\max} and U_{\min} are voltages applied in the two states of the ferroelectric capacitor and n is the tunability determined as the ratio

$$n = \frac{\varepsilon(U_{\min})}{\varepsilon(U_{\max})}. \quad (3)$$

Usage of ferroelectrics in phased arrays has been presented in [21, 17]. Three possible configurations: two traveling wave types and another lens type antenna, have been discussed. However, there is a drawback in this approach: very high DC bias (max is about 13.5 kV).

A new type of reconfigurable microstrip antenna has been presented in [16]. This novel concept is based on the utilization of the voltage-controlled ferroelectric materials. The antenna consists of a multilayered structure with thin ferroelectric tape sandwiched between two dielectric slabs, which are located on the conductive plate.

Microstrip antennas on ferroelectric substrates have been investigated in [33]. In [18] a new method of null pattern synthesis of antenna arrays without phase shifters and attenuators has been shown. This concept is based on utilizing the voltage-controlled ferroelectric array, where the pattern of each antenna element is used to synthesize array pattern with desired nulls. It has been shown that such antenna array can provide higher directivity, narrower main lobe and lower side lobes levels than conventional phased array.

The main reason why ferroelectric materials have not been used at microwave range is the large bias voltage required to change their dielectric constant and high losses of the materials.

A new low-cost scan antenna concept has been presented in [35]. The substrate of this microstrip antenna uses a ceramic-polymer composite with modified ferroelectric powder $\text{Ba}_{0.65}\text{Sr}_{0.35}\text{TiO}_3$ and an appropriate polymer (grains of the powder were sprayed into polymer). The ceramic-polymer composite was designed to change the permittivity in response to an applied electric control field [24]. Figure 1 shows the view of the ferroelectric ceramic-polymer composite material. This ceramic-polymer composite consists of ferroelectric powder (granulated to a desired size within the range 1-5 μm). It has been utilized to obtain ceramic-polymer films. Thickness of the composite layer was selected between 100 to 500 μm . A big advantage of the ceramic-polymer ferroelectric materials over ceramic ferroelectric materials is that the former can have any dimensions (even 1 m^2), smaller permittivity (above 10) and higher tuneability comparing to the latter. These features are important for scanning antenna design.

Fig. 2 shows the basic configuration of electrically controllable scanning antenna.

This is a simple, low-cost structure in which the transmission line, phase shift section and radiating aperture are contained completely within one homogeneous ferroelectric ceramic-polymer composite microstrip line with no discrete components to be assembled. Designed antenna has been tested in the frequency range 7.7-7.9 GHz. The antenna is fed asymmetrically with a narrow quasi-TEM line. Wider microstrip transmission line (operating on the first higher order mode) is printed on 200 μm ceramic-polymer ferroelectric substrate and has the width of 10.5 mm. The length of the antenna has been chosen to be equal to 96 mm. The bias of the substrate is achieved using dedicated DC-block. It has been

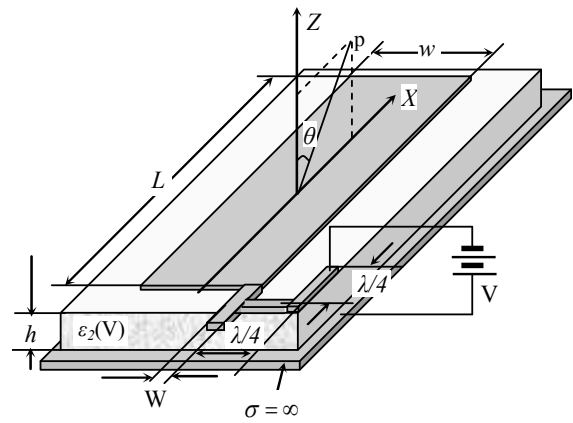

Fig. 1. Ferroelectric ceramic-polymer composite material for scanning antenna.



Fig. 2. Basic configuration of electrically controllable scanning antenna.

shown [35] that the beam angle can easily change over 30 $^{\circ}$ with varying DC bias field up to 200V.

Beside the ferrite and ferroelectric materials, liquid crystals show very good RF performance. Novel approaches to tuneable devices for millimetre waves utilizing liquid crystal have been presented [10]. Authors have described a concept of a tuneable liquid crystal phase shifter in LTCC (Low Temperature Cofire Ceramics) technology and a tuneable high-gain antenna based on a liquid crystal tuneable reflectarray. It has been shown that continuous beam scanning is between $\pm 25^{\circ}$. Other examples of using liquid crystals are found in [5]. Authors proposed the use of a liquid crystal substrate for a patch antenna whose frequency can be tuned by changing the biasing voltage across the substrate. It has been found that by varying the biasing voltage from 0 V through 11V, operating frequency of the circular patch antenna changes from 1.08 GHz up to 2.35 GHz.

C. MEMS for Continuous Reconfiguration

In tuneable antennas, varactors are used to continuously tune the operating frequency of the antenna. For example, the length of a microstrip patch antenna can be adjusted to obtain continuous tuning of the operation frequency. The advantage of this configuration is that a single antenna element can be

tuned to operate in a narrow frequency band. Typically, antenna has to be matched for operation at a fixed frequency. A broadband matching network could be employed to provide a reasonable return loss in the desired operating frequency range.

With the appearance of RF MEMS devices, there has been a considerable interest in the development of reconfigurable antennas. RF MEMS devices can be integrated with antennas for changing the operating frequency and/or the radiation pattern.

There are many possibilities of comprehensive use of the RF MEMS devices for changing antenna's parameters. To mention a few among many:

- frequency tuning by changing the effective dielectric constant.
- beam scanning.
- beam steering.
- electronic beam scanning using MEMS phase shifters or true-time-delay line.
- antenna pattern reconfiguration.
- beam steering by means of reflect array antennas.

A brief overview of the current state of RF MEMS devices applicable to reconfigurable antenna systems is given in this part of paper.

A frequency tunable microstrip antenna can be designed similarly as ferroelectric antenna because the effective dielectric constant can also be changed in case of MEMS devices. Such antenna consists of a microstrip radiator supported by two or four suspension springs. Radiator is able to move in the direction of normal to the patch. Operating frequency of the antenna can be tuned electrostatically by applying a DC bias voltage between the patch and the ground plane. Moveable patch suspended along dielectric layer drags downward the ground plane according to electrostatic force. This decreases the air gap and in turn increases the effective permittivity of antenna, and causes the reduction of the resonant frequency.

The digital micromirror device (DMD) has been developed by Texas Instruments's for mechanically beam steering reconfigurable antennas [28]. The main element is a micromechanical torsional antenna element similar to a mirror, which can be tilted. The antenna element consists of a flat microstrip segment supported by two torsional springs. The angle of radiation of the antenna can be changed by angular or torsional rotation of the radiating segment. This can be accomplished by using electrostatic, electromagnetic or electrothermal actuation mechanisms.

In [1], magnetic actuation was employed to develop a two-dimensional mechanical beam-steering antenna. The antenna was fabricated on a single high-resistivity silicon substrate and uses a polymer-based hinge structure. A magnetic material located on the backside of the plate, is actuated by an off-the-shelf solenoid coil. A maximum beam-scanning angle of up to 40° was obtained.

Phased array antenna can steer transmitted and received signals without mechanical rotating of the whole antenna. This type of array consists of multiple stationary antenna elements, which are fed coherently and, uses variable phase or time-

delay control at each element to scan the beam to angles given in the space. Each radiating element of a phased array is associated with a phase shifter or a T/R module with the phase that can be varied through 360° . Electronically scanned microwave antennas are accomplished by electrical altering of the phase across the antenna radiating aperture (by means of discrete phase shifting elements). Electronic beam scanning using MEMS phase shifters is also possible by means of adjusting the phase of the single fed to the antenna element. The usage of true-time-delay phase shifters instead of conventional phase shifters allows to avoid undesirable frequency scanning.

A true-time-delay MEMS phase shifter, which can provide group delay control, is based mainly on a switched-line [11] or distributed loaded-line design [3]. True-time-delay MEMS phase shifter can be a key element of the lenses and reflect arrays for passive electronically scanned array [6]. The lens consists of the antennas and true-time-delay phase shifters. The lens captures a space wave, delays and reradiates wave to space. Reflect array is based on tunable impedance surfaces [7]. There has been considerable interest in the development of a printed reflect array. This kind of antenna is capable of producing reconfigurable beam patterns suitable for high-gain applications. The tunable reflect array cell reradiates the incident field with appropriate phase shifts required for formation of a desired pattern. MEMS phase shifter and antenna element can be integrated with reflect array to enable electronic reconfiguration [23].

The main disadvantage of electrostatic actuation-based RF MEMS devices is that these devices exhibit pull-in instability above the pull-down voltage. As a result, frequency tuning can be achieved only in a narrow frequency range below the pull-down voltage. Furthermore, frequency will remain constant until the applied voltage is decreased to the release voltage and thus the frequency tuning is not typically controlled during the release process.

III. DISCRETELY RECONFIGURABLE ANTENNAS

The leading technology for reconfigurable system is based on switchable antenna elements. The reconfigurable antennas are usually equipped with switches that are controlled by DC bias signals. The switches and the accompanying control system are very often an integral part of the reconfigurable antenna. The antenna can be reconfigured to support a discrete set of operating parameters, e.g. frequency, polarization, radiation pattern by switching between the on and off states of the switches. Each reconfigurable antenna employs a distinct mechanism in order to achieve the required reconfigurability, e.g. photonic, solid state or MEMS switches [32].

The fundamental role of a switch or relay is to make or break an electric circuit. In static and quasi-static regimes, a switch operates simply as either a conduction path or a break in the conduction path. However, switch operation in an RF system will include additional electrical properties. Switch resistance, capacitance and inductance along the RF signal path must be taken into account in the analysis of the system. In antenna systems, switch function typically implicates the controlling and directing of the flow of RF energy along a

desired RF path. Traditionally, this path may include any of the RF subsystems leading to the antenna feed distribution network as well as the antenna feed and, in the case of arrays, any power distribution network. Irrespectively of the type of the switch used, there are several important characteristics that must be evaluated for all RF switch applications and particularly reconfigurable antenna designs. The selection of switch type depends fundamentally on the switching speed required by the application and the switched signal power level. Other critical parameters to consider in the selection of RF switches include impedance characteristics, switch biasing and activations conditions, package and form factor, and switch cost.

Generally, reconfigurable antennas by RF switches technology can be divided into two groups:

- ones which use fixed separated switches placed on the aperture (the following can be used as switches: PIN diodes, FET transistors or MEMS),
- ones which use temporarily created switches, e.g. made on a semiconductor substrate.

Furthermore, a typical reconfigurable structure has the following basic component parts: multilayer planar or 3D antenna arrays and their corporate feed network, switching networks and their bias circuits and ground plane which may consist of multi-screen frequency selective surfaces or photonic band-gap structure.

A. Reconfiguration by Means of Separated Switches

An example of the first group is a reconfigurable aperture concept derived from fragmented aperture design where the configuration of the fragmented aperture may be switched by the user to obtain different functionalities [13, 20]. Figure 3 shows the concept of the fragmented aperture with switches in the on and off states.

This reconfigurable structure is called a *pixel-patch antenna* and consists of a matrix of conducting patches with switches between some or all of the small patches. These reconfigurable apertures can change functionality by opening or closing of different connections between these patches.

In the prototype antenna, the switches were electronic and controlled via infrared illumination. A light-emitting diode (LED) in the control circuitry sends infrared radiation through a hole in the reflector. The beam then passes through a light tube in the honeycomb spacer. The sides of the channel are painted to make them reflective and lightproof – this increases the efficiency of the light transfer and prevents crosstalk between channels. The light beam finally strikes a photodetector located on the backside of the dielectric substrate containing the metallic patches. Here, the light beam activates an electronic switch connecting two patches – when the light is on, the switch is closed, and when the light is off, the switch is open.

B. MEMS for Discrete Reconfiguration

For some applications, MEMS switches can be applied. There are several ways to actuate the MEMS switches such as: electrostatic, thermal, magnetostatic or piezoelectric. Among these actuation mechanisms, electrostatic force is widely used due to its simplicity, compactness and low power

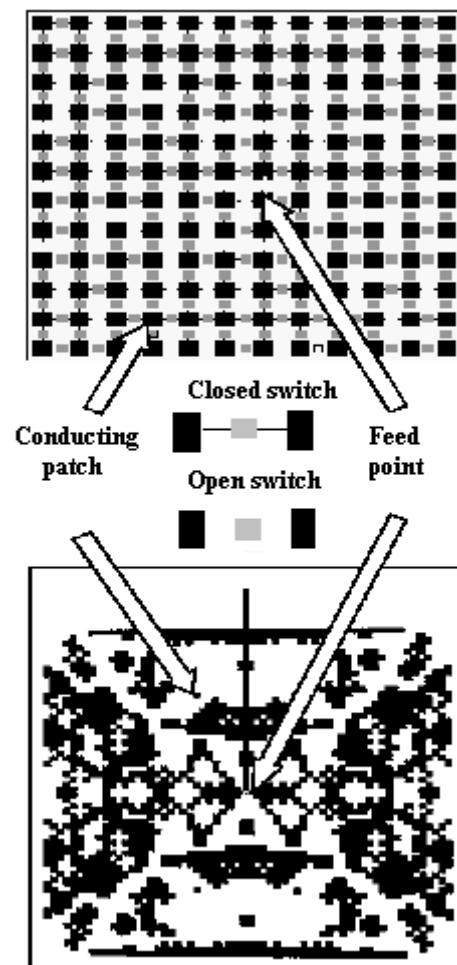

Fig. 3. Concept of the fragmented reconfigurable aperture [13, 20].

consumption. Although MEMS switches have some disadvantages, such as medium switching speed and low power capability compared to solid state and ferroelectric-based devices, they achieve excellent performance such as: very low insertion loss, high linearity and high isolation. Table I summarizes the performance comparison of MEMS switches with the standard FET switches and PIN diodes [22].

The switches based on PIN diodes and FET transistors inherent loss which reduces the radiating efficiency of the antenna. The use of the solid state switches also introduces the limitation on the power that can be handled by the antenna, and the possibility of unwanted nonlinear effects, both on transmission and reception. It would be highly desirable to have a switch for reconfigurable antennas that alleviates these potential problems. It seems that the MEMS switches can offer promising characteristics in this regard.

RF MEMS switches can be widely used to reconfigure the radiating structure or aperture of the antenna and in turn, for example, discrete switching between two or more operating frequencies.

In the frequency switching reconfiguration, RF MEMS devices are used to switch between, e.g. two different frequency bands by choosing an appropriate ratio of physical

TABLE I
COMPARISON OF PERFORMANCE OF FET, PIN AND MEMS SWITCHES

Parameter	RFMEMS	PIN	FET
Voltage [V]	20 – 100	3 – 5	3 – 5
Current [A]	0	3 – 20	0
Power Consumption [mW]	0.05 – 0.1	5 – 100	0.05 – 0.1
Switching Time	1 – 200 μ s	1 – 100ns	1 – 100ns
Cup (Series) [pf]	1 – 6	40 – 80	70 – 140
Rs(Series)[Ω]	0.5 – 2	2 – 4	4 – 6
Capacitance Ratio	40 – 500	10	-
Cutoff Freq. [THz]	20 – 80	1 – 4	0.5 – 2
Isolation (1 - 10 GHz)	Very high	High	Medium
Isolation (10 - 40 GHz)	Very high	Medium	Low
Isolation (60 - 100 GHz)	High	Medium	-
Loss (1 - 100 GHz) [dB]	0.05 – 0.2	0.3 – 1.2	0.4 – 2.5
Power Handling [W]	< 0.5	< 10	< 10

structures, for example lengths of the antenna. This type of antenna would also require reconfigurable matching network to obtain good impedance matching at various operating frequencies.

C. Reconfiguration by Means of Temporarily Created Switches

The main disadvantage of the reconfiguration with the use of fixed separated switches is that all separated switches are placed on the aperture, although only some switches are involved in the „generation” of the desired radiation pattern.

An example of the group which uses temporarily created switches is the plasma regions with fairly high electrical conductivity, which are temporarily created on a silicon substrate [14, 8, 9]. These regions define the antenna structure, and they can be changed to create different antennas. Concept of the holographic reconfigurable aperture is shown in Fig. 4.

The holographic antenna is based on a semiconductor chip that contains a set of individually controlled surface PIN structures. Electromagnetic waves propagate through the chip, which also serves as a planar dielectric waveguide. Through selective activation of the PIN devices various surface antenna patterns can be produced. In holographic antenna, the PIN devices are activated to produce a simulated metallization pattern that is excited by a surface wave, transmitted from a surface mounted dipole antenna [26].

The new type of semiconductor antennas have been designed and investigated in the Institute of Radioelectronics at the Warsaw University of Technology. The semiconductor antenna means that the antenna utilizes the semiconductor material as a substrate, which parameters can vary.

The key element of the mentioned and presented concepts is a surface PIN (S-PIN) device [26]. S-PIN devices are not widely used in the microwave and millimeter wave range applications. The structure of the S-PIN diode differs significantly from a conventional PIN diode used as a switching device and well-known to microwave engineers. The structure of a standard PIN diode is bulky, even if the device is fabricated in a planar technology. The inner intrinsic (very lightly doped) layer is placed between two areas with high concentration of carriers - N⁺ and P⁺. Dimensions of this inner area depend on, for example, the desired isolation, switching time, and required breakdown voltage. In some

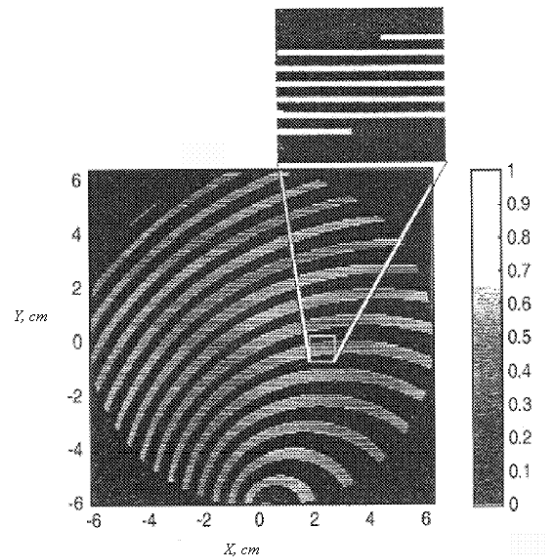

Fig. 4. Concept of the holographic reconfigurable aperture.

cases the structure is cylindrical. It provides requested mechanical, thermal and electrical parameters of the devices.

In the OFF state, while the diode is not biased, the S-PIN device offers the high resistance of the area between the doped regions. In the ON state, it is characterized by the low resistance of the plasma of injected carriers in the surface area, when the diode is strongly biased in the forward direction. The plasma should be conductive enough to become an equivalent of a quasi-metallic layer. It is also requested, for several applications, that the metal contacts, used for biasing the diode, should be as small as possible. In order to be used at microwave and millimeter wave ranges, the S-PIN diode has to provide a possibility of the dynamic switching between OFF and ON states.

The first antenna to be discussed is a new fixed-frequency beam-steerable reconfigurable leaky-wave antenna [27]. The concept is based on the usage of a semiconductor substrate for creating surface S-PIN, which are utilized to switch between the different aperture configurations by means of the width of the aperture. It has been observed that the change of the width of the microstrip line operating in its first higher-order mode is accompanied by a noticeable shift in the cutoff frequency of the first higher-order mode. This effect has been used in the design of antennas with a continuously adjusting operating frequency range. It can be seen that approximately 35^o main-beam scan range has been achieved at a constant frequency $f=7.9$ GHz by lightly changing the width of the aperture.

The second example of reconfigurable antenna is a more advanced structure based on the array of surface p-i-n diodes integrated with radiators. “Generating” a desired radiation pattern can be obtained by the following steps: the traveling wave propagates along the semiconductor (silicon) layer, on which the grid of S-PIN devices is formed. In the S-PIN diodes, the carriers are confined to the top surface. Injection of a DC current into S-PIN diodes induces the plasma of carriers in the intrinsic region, which appears to be like a conductive

layer for microwaves. This diode array is addressable by a control circuit.

In our case, at the first moment, the grid of S-PIN diodes is turned OFF (no bias). In this state, the highly resistive silicon substrate behaves like insulator and may be used as a dielectric waveguide. Then a block of the synthesis of the requested radiation pattern processes the initial data. It outputs as a result, a binary sequence that defines which of S-PIN devices should be turned-on. The number of bits at bit sequence depends on the number of S-PIN diodes. In our cases, we have investigated 64 and 128 pairs of the S-PIN diodes.

The sequence is passed to a control circuit, in order to obtain a requested DC current for activating the S-PIN diodes. Thereby a conductive aperture pattern is created, which in turn causes the generation of the desired shape of radiation pattern. Thus, by turning the S-PIN structures ON and OFF selectively, it is possible to obtain instantaneously the desired conductive pattern. Therefore, at a fixed frequency, the main beam can be electronically switched among the several shapes of the radiation pattern or beam directions, or the antenna may be tuned to several desired frequencies.

Using these types of reconfigurable antennas is advantageous for many applications. First of all, the reconfigurable antennas can be used for obtaining broadside beams for different frequencies. It has been proved that for a standard equidistance array excited by a traveling wave, it is impossible to obtain broadside radiation covering range from 20-40 GHz, while our design reconfigurable aperture makes such coverage possible.

Another application is the use of a reconfigurable antenna to design a scanning antenna array. Our results prove that the desired directions in the range of $\pm 40^\circ$ can easily be covered. Additional advantage is the lack of diffraction beams for a large scanning. These diffraction beams are a great disadvantage of the phased array antennas.

A similar concept of a reconfigurable antenna [34] has been realized on a reconfigurable slot aperture, which was placed instead of one wall of a metallic rectangular waveguide [36]. A standard rectangular waveguide WR-42 has been used with S-PIN diodes mounted on the narrow wall of the waveguide (Fig. 5).

The S-PINs forming array of „slots” are placed in a skew-symmetric manner, which is clearly visible in Fig. 5 showing a fragment of this chip wired to the external system. The reconfigurable elements form an array similar to a waveguide slot antenna but with large amount of slots. As small as possible distance between the nearest slots on the aperture has been chosen. Every slot could be used for the generation of a requested radiation pattern. At the forward bias, a wide slot (between two conductive area) in metallization is short-circuited by conducting plasma of carriers. This antenna has been investigated in the wide frequency range: from 17 GHz to 34 GHz for different configurations of the diodes being in the ON and OFF states. The results, published in [37], prove that this device can emit radiation beam to the desired direction or it can operate at different frequencies, while supporting radiation in the similar directions.

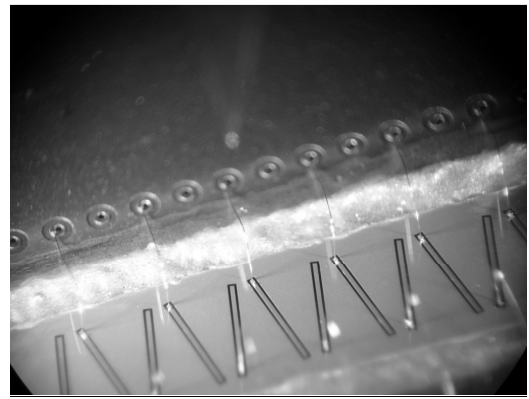

Fig. 5. Part of the ready device wired to the control system.

IV. CONCLUSIONS

The brief overview of the current state of reconfigurable antenna systems has been given in this paper. It has been shown that there are four main mechanisms of changing the antenna's parameters: mechanical/electromechanical, e.g. by using the MEMS switches; electronic, e.g. by using the PIN diodes; optical, e.g. by using the photosensitive layer and electrical/magnetic, e.g. by using the special substrate media such as controllable materials (ferroelectrics, liquid crystal and ferrite). The combination of the aforementioned mechanisms is also very useful. Considering the properties of a base design, reconfigurable antennas can be classified according to the continuity of reconfiguration, which is defined by the reconfiguration mechanism: continuous (reconfiguration within a range of states) and discrete (a finite number of reconfigured states)

In this paper, two important characteristic parameters of a reconfigurable antenna - an operating frequency and radiation pattern, have been considered by means of electrical, electronic and electromechanical mechanism of continuous and discrete reconfiguration. Significant attention was given to RF switches which are available for use in reconfigurable antenna systems. In particular, it explores switches based on PIN diodes and MEMS.

The paper also presents the results of the investigation conducted in the Institute of Radioelectronics at the Warsaw University of Technology on some models of reconfigurable antennas. Discussed solutions have been based on the ferroelectric and semiconductor materials. Such approach allows us to design the electronically controlled beam-steering and electronically reconfigurable antennas. The possibility of the reconfiguration of the antenna aperture is very promising. The key element of the reconfigurable antenna is a surface PIN (S-PIN) diode whose conductivity changes proportionally to the plasma density. S-PIN structures can be activated selectively and cause, in turn, a generation of the desired shapes of radiation pattern.

REFERENCES

- [1] C.-W. Baek, S. Song, J.-H. Park, S. Lee, J.-M. Kim, W. Choi, C. Cheon, Y.-K. Kim, and Y. Kwon, "A v-band micromachined 2-d beam-steering antenna driven by magnetic force with polymer-based hinges", *IEEE Transactions on Microwave Theory and Techniques*, 51(1), 2003, pp.325-331.
- [2] C. A. Balanis. *Modern Antenna Handbook*, Wiley, 2008.
- [3] N. S. Barker and G. M. Rebeiz, "Optimization of distributed MEMS transmission-line phase shifters – U-band and W-band designs", *IEEE Transactions on Microwave Theory Techniques*, vol.48, no.11, pp.1957-1966, Nov. 2000.
- [4] N. Behdad and K. Sarabandi, "Dual-band reconfigurable antenna with a very wide tenability range", *IEEE Transactions on Antennas and Propagation*, vol. 52, pp. 409-416, February 2004.
- [5] R. Bose and A. Sinha, "Tunable Patch Antenna Using a Liquid Crystal Substrate", *RADAR'08*, May 2008, pp.1 - 6.
- [6] C. Chekroun, "Microwave phase shifter and its application to electronic scanning", U.S. Patent, 4,320,404, February 24, 1981.
- [7] A. Dorne, R. G. Malech, and W. Statre, "Grid array antenna", U.S. Patent 3,276,023, May 21, 1963.
- [8] A. Fathy, A. Rosen, F. McGinty, G. Taylor, S. Perlow, and M. ElSherbiny, "Silicon Based Reconfigurable Antennas", in *Proc. 2000 IEEE Antennas and Propagations Symposium*, Salt Lake City, 2000, pp. 325-313.
- [9] A. Fathy, et al., "Silicon-based Reconfigurable Antennas - Concepts, Analysis, Implementation, and Feasibility", *IEEE Transactions on Microwave Theory and Techniques*, vol. 51, no. 6, pp.1650 – 1661, June, 2003.
- [10] A. Gaebler, et al., "Liquid Crystal-Reconfigurable Antenna Concepts for Space Applications at Microwave and Millimeter Waves", Hindawi Publishing Corp., *International Journal of Antennas and Propagation*, ID876989.
- [11] J. B. Hacker, R. E. Mihailovich, M. Kim, and J. F. DeNatale, "A Ka-band 3-bit RF MEMS true-time-delay network", *IEEE Transactions on Microwave Theory Techniques*, vol. 51, no.1, pp. 305-308, January 2003.
- [12] M. J. Lancaster, J. Powell, and A. Porch. *Superconductors Science Technologies*, 11, 1323, 1998.
- [13] J. C. Maloney, M. P. Kesler, L. M. Lust, L. N. Pringle, T. L. Fountain, and P. H. Harms, "Switched Fragmented Aperture Antennas", in *Proc. 2000 IEEE Antennas and Propagations Symposium*, Salt Lake City, 2000, pp. 310-313.
- [14] M. Matsumoto, M. Tsutsumi, and N. Kumagai, "Radiation of Millimeter waves from a Leaky Dielectric Waveguide with a Light-Induced Grating Layer", *IEEE Transactions on Microwave Theory and Techniques*, vol. MTT-35, pp. 1033 –1042, Nov. 1987.
- [15] F. A. Miranda, F.W. Van Keuls, R.R. Romanofsky, C.H. Mueller, S. Alterovitz, and G. Subramanyam. *Integrated Ferroelectrics*, 42, 131, 2001.
- [16] J. Modelski and Y. Yashchyshyn, "Investigations of the Microstrip Antenna on Ferroelectric Substrates", *30th European Microwave Conference 2000*. France, Paris, October 2-6, 2000, pp. 162-165.
- [17] J. Modelski and Y. Yashchyshyn, "Voltage-controlled ferroelectric microstrip antenna for phased arrays", *2000 IEEE International Symposium on Antennas and Propagation and USNC/URSI National Radio Science Meeting*. USA, Utah, Salt Lake City, July 16-21, 2000, pp. 506-509.
- [18] J. Modelski and Y. Yashchyshyn, "Null Pattern Synthesis of Ferroelectric Smart Antennas". *IEEE MTT-S International Microwave Symposium Digest*, Phenix, Arizona, USA, May 20-25, 2001, Vol.1, pp.467-470.
- [19] D. Packiaraj, V. S. Reddy, G. J. D'Mello, and A. T. Kalghatgi, "Electronically switchable suspended substrate stripline filters", in *Proc. RF and Microwave Conference*, Oct. 2004, pp. 64 – 66.
- [20] L. N. Pringle, et. al., "A Reconfigurable Aperture Antenna Based on Switched Links Between Electrically Small Metallic Patches", *IEEE Transactions on Antennas and Propagation*, vol. AP-52, pp.1434 – 1445, June 2004.
- [21] J. B. L. Rao, G. V. Trunk, and D. P. Patel, "Two Low-Cost Phased Arrays," *IEEE Aerospace and Electronic Systems Magazine*, Vol.12, pp.39-44, 1997.
- [22] G. M. Rebeiz, *RF MEMS Theory, Design, and Technology*. John Wiley and Sons, 2003.
- [23] J. K. Smith, "Special session – reconfigurable aperture antennas" *IEEE International Symposium on Antennas and Propagation and USNC/URSI National Radio Science Meeting*. USA, Utah, Salt Lake City, UT, July 2000.
- [24] M. Szafran, E. Bobryk, J. Modelski, and Y. Yashchyshyn. Kompozyt ceramika-polimer do zastosowań mikrofalowych i sposób wytwarzania kompozytu ceramika-polimer do zastosowań mikrofalowych. Patent PL, priority BUP02-05-200509/2005, published WUP30-01-200901/2009, [in polish].
- [25] A.K. Tagantsev, V.O. Sherman, K.E. Astafiev, J. Venkatesh, and N. Setter. Ferroelectric Materials for Microwave Tunable Applications. *Journal of Electroceramics*, 11, 5-66, 2003.
- [26] G. C. Taylor, et. al., "Reconfigurable Antenna", U. S. Patent no.: US 6,567,046 B2, May 20, 2003.
- [27] G. C. Taylor, A. Rosen, A. E. Fathy, P. K. Swain, and S. M. Perlow, "Surface PIN device", U. S. Patent no.: US 6,617,670 B2, Sep., 9, 2003.
- [28] H. Toshiyoshi and H. Fufita, "Electrostatic micro torsion mirrors for an optical switch matrix", *IEEE Journal Microelectromech. Synt.* 5(4), 1996, pp. 231-237.
- [29] O.G. Vendik, E.K. Hollmann, A.B. Kozyrev, and A.M. Prudan. *Journal of Superconductivity*, 12, 325, 1999.
- [30] G. Washington, H.-S. Yoon, M. Angelino, and W. H. Theunissen, "Design, modeling, and optimization of mechanically reconfigurable aperture antennas", *IEEE Transactions on Antennas and Propagation*, vol. 1, pp. 179 – 181, 1991.
- [31] X.X. Xi, H.C. Li, W.D. Si, A.A. Sirenko, I.A. Akimov, J.R. Fox, A.M. Clark, J.H. Hao. *Journal of Electroceramics*, 4, 393, 2000.
- [32] S. Yang, C. Zhang, H. K. Pan, A. E. Fathy, V. K. Nair, "Frequency-Reconfigurable Antennas for Multiradio Wireless Platforms", *IEEE Microwave Magazine*, vol.10, nr. 1, pp.66-83, Feb. 2009.
- [33] Y. Yashchyshyn, J. Modelski. "The Leaky-Wave Antenna With Ferroelectric Substrate", *Proc. IX Intern. Conf. On Microwaves, Radar and Wireless Communications MIKON'2002*, Vol.1, Gdansk, Poland, May 20-22, 2002, p.218-221.
- [34] Y. Yashchyshyn, J. Modelski, "A Reconfigurable Leaky-Wave Microstrip Antenna" in *Proc. 35-th European Microwave Conference*, Paris, France, Oct. 2005.
- [35] Y. Yashchyshyn, J. Modelski, "Rigorous Analysis and Investigations of the Scan Antennas on a Ferroelectric Substrate", *IEEE Transactions on Microwave Theory Techniques*, Feb. 2005, pp. 427 – 438.
- [36] Y. Yashchyshyn, K. Derzakowski, J. Modelski, "Extending Functionalities of Waveguide Slot Antennas by Means of Reconfigurable Aperture", in *Proc. 38-th European Microwave Conference*, Amsterdam, The Netherland, Oct. 2008, pp. 268-261.
- [37] Y. Yashchyshyn, J. Marczewski, K. Derzakowski, J. Modelski, P. Grabiec, "Development and Investigation of an Antenna System with Reconfigurable Aperture" *IEEE Transactions on Antennas and Propagation*, vol. 57, no. 1, Jan., 2009.
- [38] S. Zhang, G. H. Huff, G. Cung, J. T. Bernhard, "Three variations of a pattern-reconfigurable microstrip parasitic array", *Microwave Optical Technology Letters*, vol.45, pp. 369 – 372, June 2005.