

# Design of Wearable EEG Device for Seizures Early Detection

Viktoriia Gaidar, and Oleksandr Sudakov

**Abstract**—This paper presents the design of a wearable electroencephalography device and signal processing algorithm for early detection and forecasting of the epileptiform activity. The availability of the examination of functional brain activity for a prolonged period, outside of the hospital facilities, can provide new advantages in early diagnosis and intervention systems. In this study, the low-cost five-channel device is presented. The system consists of two main parts: the data acquisition and transmission units and processing algorithms. In order to create the robust epileptiform pattern recognition approach the application of statistical sampling and signal processing techniques are performed. The discrete wavelet and Hilbert-Huang transforms with principal component analysis are used in order to extract and select a low-dimension feature vector.

**Keywords**—circuit design, statistical sampling, Hilbert-Huang transform, feature selection

## I. INTRODUCTION

THE debilitating consequences of abrupt seizures is one of the threads of the epilepsy disease. It is common neurological disorder that causes the abnormal electrical activity in the brain. The uncontrolled epilepsy seizure occurrence lay the burden on the daily life activity for people, who suffer from the condition. According to the studies [1] the unpredictability of seizures is the major impactful factor of epilepsy.

In many cases, people do not have any physical signs. Only small percent of the patients could feel the so called aura before the seizure occurred.

The vast majority of patients use medical supplies, which prevents them from seizures. Such treatment provides the control of the seizures occurrence and alleviate social and mental anxiety. But unfortunately, almost 30% of the patients are experience the medical resistant form of epilepsy. Therefore, the task of forecasting of the seizure occurrence is a major field of neurological research. It is based on analyzing the features derived from electroencephalographic recordings. The warning system, that may forecast the seizure prior to its physical manifestation has been the goal for many researchers since digital electroencephalography.

The electroencephalography (EEG) is a safe and multi-functional technique to detect electrical activity of the brain. It is a clinical tool that used to localize and identify the epilepsy syndrome [2]. In the clinical examination the EEG

This work was supported by Bogomoletz Institute of Physiology of NAS of Ukraine. The experimental in-vivo intracranial electroencephalography data provided by the Bogomoletz Institute of Physiology was used in this study.

The Authors are with Taras Shevchenko National University of Kyiv, Ukraine (e-mail: gaidar.viktoriia@gmail.com, sudakov.oleksandr@gmail.com).

diagnosing procedure takes place for a couple of hours or even days. Even so, sometimes it is hard to detect the epileptiform patterns during the EEG diagnosis process. The epileptiform activity presented in interictal epileptiform discharges (IED). According to the [3], epileptiform discharges may occur up to 24 hours after partial and generalized seizures and it was proved that within this period increases the likelihood of obtaining IED. Pattern recognition of epileptic and preictal states based on feature selection and extraction derived from the EEG signal is the major task of research.

This paper is focused on two main goals. The first is to design the wearable EEG system for signal acquisition. The second one is to provide a fast and suitable algorithm for detecting the pre-ictal and ictal activity prior to the seizure occurrence.

## II. WEARABLE EEG SYSTEM

The new approaches in a field of wireless transmission of the data caused the advantages of the computer-brain interfaces and monitoring systems. For decades the only option to provide medical examination was ambulatory EEG monitoring. It is high precision systems that conduct from 32 to 128 electrodes and can operate for days during one examination session. EEG systems divided into non-invasive and intracranial electrodes placement. For epilepsy studies, the first on scalp technique is commonly used for the medical diagnosis of epilepsy disorder. For the patients with rare conditions, in most of the cases with drug resistance epilepsy, the intracranial systems are used. It provides the opportunity to collect the data during the weeks and month to design individual medical treatment.

The rapid evolve in wireless technology conduct the evolution in miniaturized EEG units for prolonged monitoring studies [4]. The wearable EEG monitoring systems faced some common issues. The main tradeoffs of such approaches are system power consumption and the optimal method for data compression. Also, to make wearable EEG devices feasible it is necessary to provide sustainable amplification system and perform optimal number of electrodes.

To reduce power consumption we construct the method to create the low-dimensional feature vector. Thus to reduce the numbers of data, that needed to be preprocessed and conducted.

The EEG system design is divided into three main categories: signal acquisition, signal transmission, and signal



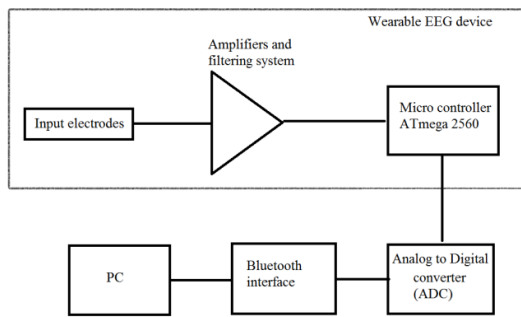

Fig. 1. Basic block diagram of the wearable EEG system

processing. For signal acquisition, the international 10-20% electrodes placed on the scalp system was used [5].

For signal transmission the golden plated medical electrodes were used. From the isolated wires from the band the data then transmitted to the intermediate microcontroller and than via Bluetooth module sent to the computer.

In order to provide the substantial signal processing algorithm, the new approach for extraction and selection of low-dimensional feature vector was conducted. It has been tested on the in-vivo datasets of the rats to reduce the influence of the additional artifacts.

#### A. Amplification and Filtering

There are two common montages used for data acquisition: bipolar and monopolar. In the monopolar montage, one electrode is active and the other one is reference electrodes. For bipolar montage two electrodes are active and the potential difference between them is measured. In this work, we use monopolar montages. The reference electrode must be as electrically neutral as possible. Basically, we record the difference between the potential of the active site and the reference site.

Fig. 1. is shown the basic block diagram where a signal is taken from electrodes and then goes through amplifiers and filters then it is digitized and transmitted via Bluetooth module to PC. The amplitude of the EEG signal measured in microvolts and varies between 1-150  $\mu\text{V}$ . The signal is quite sensitive to biological artifacts and environmental noises that is why sufficient filters and amplifiers are important.

The signal is first acquired with gold plated electrodes (using electrolytic gel) and fed into the instrumentation amplifier block (in which canceled out the common modes noises). After the pre-amplifier stage, it passes through a high pass filter to remove DC offsets to the operational amplifier for 2nd stage amplification.

The signal again is high passed and then amplified in the 3rd stage. The 3rd stage amplifier also acts as a notch filter to remove aliasing noise, which occurs when the signal is digitized. And then finally its low passed to remove higher frequencies above 45 Hz. The process is shown in Fig. 2 [6].

For forecasting and early detection purposes it is needed to track the dynamics of the brain activity between the normal state and ictal periods. During the last few decades it was proven [7] that the seizure occurrence may be detecting prior

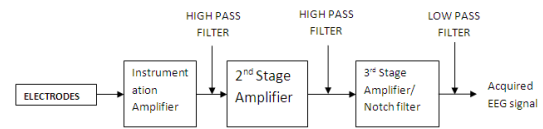

Fig. 2. Block diagram of Acquisition phase

it physical appearance. Clinical evidence for existence of pre-ictal periods is proving the feasibility of creating the robust alarming system of seizure upcoming events.

#### B. Data Transmission

The common practice during the EEG examination is when a signal recorded for a long period (from hours to a few days). In this case, the wires while examination restricts patience movements. The rapid development of wireless technology includes Bluetooth and WiFi provides new approaches for EEG medical examination.

We used the HC-06 Bluetooth module from Gunzhou HC Information Technology Co. to connect our wearable EEG device with the computer via a USB port using the UART data transmission protocol. It works at the low voltage 3.1 - 4.2 V and 30 - 40 mA current during the pairing. For analyzing and displaying data collected from electrodes we created a simple graphical user interface in Matlab.

We used Multisim simulation software for the EEG circuit simulations. The schematic contains three main parts: pre-amplification circuit with an instrumental amplifier, amplification, and the active twin T-notch filter to reduce power-line noise.

The EEG signal is typically from 1 to 100 $\mu\text{V}$  in amplitude and frequency band from 1 - 45 Hz (delta - 1-3 Hz, theta - 4-7 Hz, alpha - 8-12 Hz, beta - 13-30 Hz). Human skin has high impedance on the order of tens of  $k\Omega$  to  $1M\Omega$ , so the instrumental amplifier in the pre-amplification circuit requires much higher input impedance to avoid attenuation of the EEG signal.

The first stage of the amplification circuit consists of an instrumentation amplifier AD620AN. The AD620 is a low cost, high accuracy instrumentation amplifier that is low powered (only 1.3 mA max supply current) with only one external resistor to set gains of 1 to 10 000.

We performed the simulation for the two sine waves with amplitude 10 - 200 $\mu\text{V}$  and with frequency 3 - 45 Hz which is closed to real EEG signal. The results of modulation are shown below (Fig. 3.). The final amplification is from tens of  $\mu\text{V}$  to hundreds of  $\text{mV}$ . Along with the amplification the preprocessing and filtering circuits are an important parts of the system.

The biological artifacts such as electrooculogram and electromiogram increase the data that needed to be transmitted and pre-processed. Let alone those artifacts, the external noises influenced on the aquisition processes. That is why some additional filters have been embedded in the output circuit.

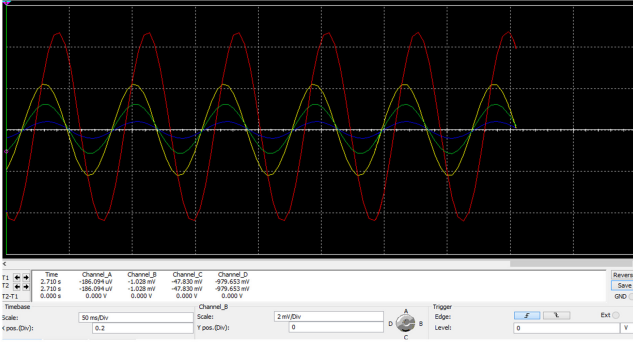

Fig. 3. The Multisim modulation of amplification circuits results: blue – input, green – after 1st stage, yellow – after 2nd stage, and red – the final output

It helps to save some power supplies, which plays reasonable role in mobile devices.

### III. SIGNAL PROCESSING

The designed EEG system consists only four active elements, so it could be used while the daily life activity. On another hand, this fact imposes certain requirements on the signal processing system. To provide a robust algorithm with fewer electrodes, we need to find the optimum solution of the feature vector extraction and selection processes.

In common, features represent a distinguishing functional component or a specific measurement. One of the first comprehensive studies [8] shows how to determine features from EEG recordings for epileptic seizures detection. In this study was constructed 30 features including bi-variate and multi-variate features as well as linear and non-linear ones.

In our study, for each of the seizure and non-seizure epoch, the following features have been extracted: Hjorth's parameters (such as activity, mobility, and complexity), standard deviation, skewness, kurtosis, entropy. Also, the Hilbert-Huang and Discrete Wavelet parameters have been included in the feature vector.

### IV. FEATURE EXTRACTION AND SELECTION

This task might be divided into two: feature extraction and feature selection techniques. Feature selection maps features into a new low-dimensional space. The new vector is usually the combinations of original features and may be obtained after principal component analysis (PCA) or similar technique. On contrary, the feature extraction approaches aim to select the small subset of features without losses in relevance to specific target. In our case, it is the class labels of epileptic and non-epileptic states.

Both feature selection and extraction lower computational complexity, decrease storage memory and computational time and build simply model with the same learning performance for classification.

In common, features represent a distinguishing functional component or a specific measurement. In order to use algorithm for wearable device we need to lower computational

complexity, decrease storage memory and computational time. To build the simple model with accurate detecting we extract basic statistical measures of signal and of coefficients in wavelet and hilbert-huang transform.

The basic statistical features that are used for signal analysis are minimum and maximum values, mean, variance, skewness, curtosis. For the EEG signal  $x(t) = x_1, x_2, \dots, x_n$  and mean value  $x_m = \frac{1}{n} \sum_{i=1}^n x_i$ . The mean value is average value on specific time-period(epoch). The dispersion is calculated as(1):

$$var(x) = \frac{1}{n-1} \sum_{i=1}^n (x_i - x_m)^2 \quad (1)$$

Also, the square root on dispersion  $\sigma$  has been calculated. The measure of the deviation of the sample distribution from the normal distribution is skewness(2):

$$skewness(x) = \frac{1}{n} \cdot \sum_{i=1}^n \left[ \frac{x_i - x_m}{\sigma} \right]^3 \quad (2)$$

The Equation (3) is the kurtosis, which measures the height and sharpness of the central peak to the data:

$$kurtosis(x) = \frac{1}{n} \cdot \sum_{i=1}^n \left[ \frac{x_i - x_m}{\sigma} \right]^4 - 3 \quad (3)$$

In this paper, we consider the task of simple binary classification on seizure and non-seizure periods. After feature extraction, the features combined in one vector. To decrease the dimension of this vector the feature selection method has been conducted.

The principal component analysis has been implied to classify the EEG epochs in two classes - seizure and non-seizure. The PCA [15] is a linear transformation that minimizes the reconstruction error and retained variance maximized. The PCA transform provides information about features that is more informative in case of classification. Feature selection about the original features that contain most of the essential information. So after PCA, the projection to the lower-dimensional space with selected features has used.

#### A. Hjorth's parameters

Hjorth's parameters [9] are the measures of signal complexity and they are useful for the quantitative description of EEG. For the time-series signals  $x(t)$  activity parameter indicates the signal power.

$$Activity(x) = var(x(t)) \quad (4)$$

The mean frequency of the signal is represented by the mobility parameter.

$$Mobility(x) = \sqrt{\frac{var\left(\frac{dx(t)}{dt}\right)}{var(x(t))}} \quad (5)$$

Complexity parameters indicate how the shape of a signal is similar to a pure sine wave and indicates the changes in the frequency domain.

$$Complexity(x) = \sqrt{\frac{Mobility(\frac{dx(t)}{dt})}{Mobility(x(t))}} \quad (6)$$

### B. Hilbert-Huang transform

The changes in neuronal electrochemical activity before and during the epilepsy seizure can be detected by tracking the weighted mean frequency. The Hilbert-Huang transform (HHT) [10] provides information about instantaneous frequencies and amplitudes of the EEG signal.

HHT analyses the non-linear and non-stationary signals by decomposing it into data-dependent basis functions. To apply to transform on a single-channel intracranial EEG signal [11] six Intrinsic Mode Functions (IMFs) have been extracted. The Empirical Mode Decomposition (EMD) of the  $x(t)$  of the signal can be expressed as summation of the  $i$ -th IMF component  $c_i$  and its residue  $r(t)$ :

$$x(t) = \sum_{i=1}^n c_i(t) + r(t) \quad (7)$$

The Hilbert-Huang transform  $y(t)$  of each IMF function  $x(t)$  is given by [13]:

$$y(t) = \frac{1}{\pi} \lim_{\tau_0 \rightarrow \infty} \left( \int_{t-1/\tau_0}^{t-\tau_0} \frac{x(\tau)}{t-\tau} d\tau + \int_{t+\tau_0}^{t+1/\tau_0} \frac{x(\tau)}{t-\tau} d\tau \right) \quad (8)$$

### C. Discrete Wavelet analysis

The EEG recording is a time series signal that most of the power is contained from zero to forty Hz. The changes from different functional states of the brains occurred in different frequency bands. The Discrete Wavelet Transform (DWT) reflects both frequency and temporal location properties of the signal. To compute the wavelet transform the original signal  $x(t)$  is convoluted with a scaled and translated version of the mother wavelet function  $\psi(t)$  [14].

The DWT leads to wavelet coefficients:

$$W_x^\psi(b, a) = A_\psi \int \psi^* \left( \frac{t-b}{a} \right) x(t) dt \quad (9)$$

The  $\psi$  is a mother wavelet function. In the context of epilepsy pattern recognition, the Daubechies 4 or Symlet 5 mother wavelet functions are used. The  $A_\psi$  denotes a normalization parameter,  $a$  is scaling parameter and  $b$  is translation parameters.

The wavelet coefficients quantify the similarity between the original and the wavelet function at a specific scale. In the context of epilepsy detection and forecasting features extraction the wavelet coefficients play the main role because they give information of signal in time.



Fig. 4. Wearable EEG device prototype

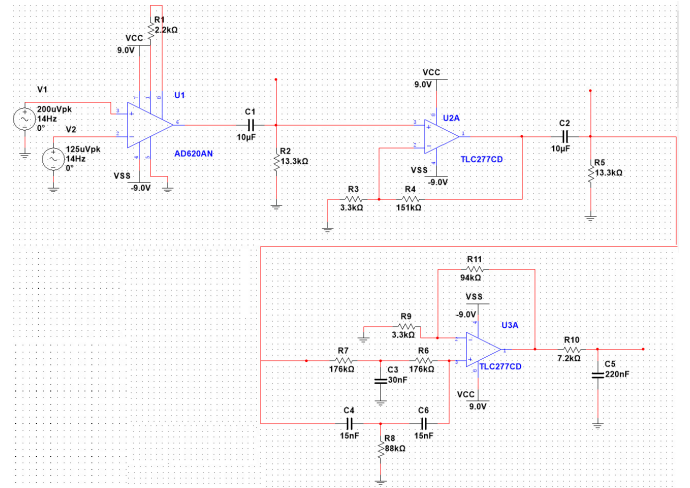

Fig. 5. The amplification EEG circuit design for one channel

## V. RESULTS

In this study we created the prototype of the EEG device with only four active and one referent electrodes placed according to 10-20% system and it is shown in Fig. 4.

As the microcontroller, we used the Arduino platform with AVR Atmega328 manufactured by Atmel. It has 32K bytes of Flash memory, six 10bit ADC channels, and programmable serial USART. The circuit schematic of the amplification system, designed for each of the electrodes, is represented on Fig. 5

The data from the electrode via isolated wires, connected to the amplification system and then via Bluetooth, transmitted to personal computer and displays on Matlab GUI in real-time. The Matlab gives advantages in providing computational power for preprocessing EEG data in real-time.

To create the solid algorithm for epilepsy state early detection, that could be used for wearable device, we firstly applied

it to one-channel intracranial recordings. The datasets has been collected from the Bogomoletz Institute of Physiology.

In-vivo datasets from fifteen rats with chemically induced epilepsy have been obtained at a sampling rate of 416 Hz. The time duration of one recording varies from one to two and a half hours for one examination. After the preprocessing datasets were segmented into pre-ictal and ictal states.

The features extended from the signal have been combined in one vector. The wavelet transform has been performed DWT coefficients for eight levels were extracted. The spectrogram is shown below on Fig. 6

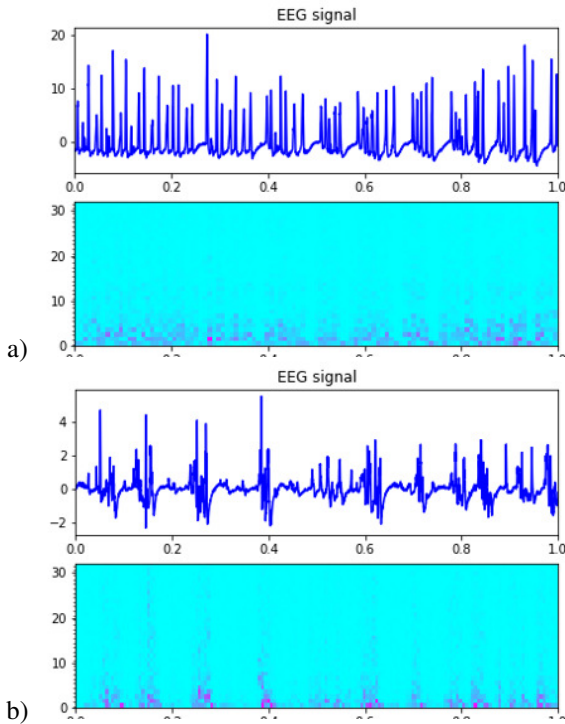

Fig. 6. DWT spectrogram on a) seized and b) non-seized epochs.

The seizure behaviour on the EEG signals is presented in abnormal synchronous discharges. Those activity causes the changes in local amplitude and the frequency of the signal. So, the Hilbert-Huang transform provides information about instant frequency and amplitude.

After the wavelet and hilbert-huang transforms the obtained coefficients were stored in one vector. The statistical features from the initial signal and the according coefficients were written in the high-dimentional feature vector.

This vector included Hjorth's parameters(activity, mobility, and complexity), kurtosis, absolute values, skewness, variation coefficients, Shanon entropy, the DWT coefficients for eight levels (the mean, energy, and entropy of wavelets coefficients also were extracted) and values of instant frequency and amplitude after Hilbert-Huang transform (also first and second derivatives of the values were calculated). The PCA analyses have been performed to reduce the dimension of the proposed feature vector (Fig. 7).

After the conducting analyses, only seven features were selected. For assessment of performed algorithm the SVM

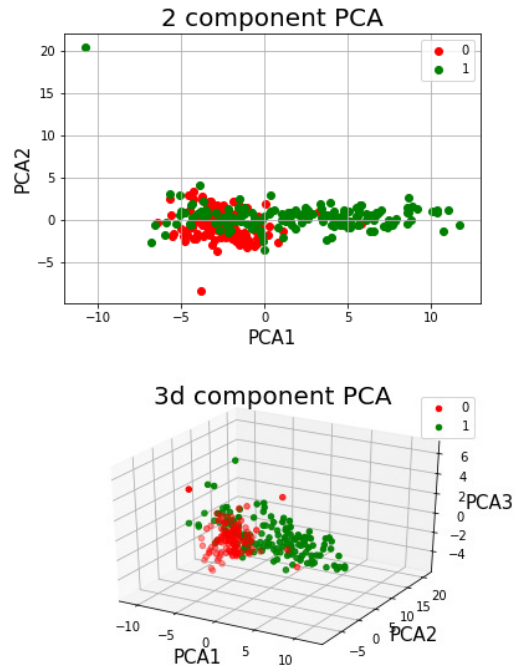

Fig. 7. PCA 2D and 3D analysis, 0 - non-seizure, 1 - seizure epochs.

binary classification has been performed with reduced feature vector as an input. We observed that the proposed algorithm provides a classification accuracy of 87,6% and a sensitivity of 95,7%.

Our results indicate that seizure events in a rat model can be detected with high accuracy with fewer features. The feature vector in the lower dimensional space provides the opportunity to reduce the computational processing of the data, which is crucial in implementing those methods on the mobile diagnosis systems an on-line monitoring systems.

## VI. CONCLUSIONS

The proposed work showed that it is possible to create a wearable cheap EEG device that can be used for epilepsy diagnosis and forecasting. The use of such mobile EEG devices provides several advantages:

- in contrast to conventional EEG examinations, the use of wearable devices provides the opportunity to examine the health care institutions and for a prolonged time;
- the fabrication process is less expensive, compared with clinical EEG devices;
- it provides the ability to collect amass data for each person, so we could create the forecasting epilepsy seizures alarm system or improve medical treatments based on obtained recordings.

Still, it is a variety of improvements that could be done in the recent researches. The next steps in this direction could be next:

- to create incorporated amplification system (so we avoid additional noise caused by wired electrodes);

- to miniaturize the system itself by using own fabricated circuit with embedded microcontroller, amplification system, ADC and Bluetooth module;
- to minimize power supply of our system and to build battery-free EEG which uses the RFID technology for power supply.

#### REFERENCES

- [1] Stacey, William C. "Seizure Prediction Is Possible—Now Let's Make It Practical.", *EBioMedicine*, No. 27,2018,pp. 3-4.
- [2] Federico, P., Abbott, D. F., Briellmann, R. S., Harvey, A. S. "Functional MRI of the pre-ictal state", *Brain* no. 128, 2005, pp. 1811 - 1817.
- [3] Smith S. J. M. "EEG in the diagnosis, classification, and management of patients with epilepsy", *Journal of Neurology, Neurosurgery & Psychiatry*. no. 76, 2005, pp. 112 - 117.
- [4] V. Mihajlović, B. Grundlehner, R. Vullers and J. Penders "Wearable, Wireless EEG Solutions in Daily Life Applications: What are we Missing?", *Journal of Biomedical and Health Informatics* vol. 19, no. 1, 2015, pp. 6-21.
- [5] Malmivuo, Plonsey, Jakko Malmivuo, Plonsey Robert, "Bioelectromagnetism: principles and applications of bioelectric and biomagnetic fields", Oxford University Press, USA, 1995.
- [6] Sudakov O., Kriukova G.,Natarov R. et al., "Distributed System for Sampling and Analysis of Electroencephalograms", in Proc. 2017 IEEE 9th International conference IDAACS 2017, Bucharest, 21-23 September 2017, pp. 306-310
- [7] Direito B. et al. "A realistic seizure prediction study based on multiclass SVM." *International journal of neural systems*, vol. 27, no. 3 , 2017.
- [8] Federico P., Abbott, D. F., Briellmann, R. S., Harvey, A. S. "Functional MRI of the pre-ictal state", *Brain*, No. 128., 2005, pp. 1811-1817
- [9] Obermaier B. et al. "Hidden Markov models for online classification of single trial EEG data.", *Pattern recognition letters*, No. 12, 2001, pp.1299-1309.
- [10] Zaena J.V. "Adaptive tracking of EEG oscillationd", *Neuroscience Methods*, 2010.
- [11] Dilran S.W., Lakshitha P.W, Sudaraka M. "Seizure prediction using Hilbert-Huang transform on field programmable gate array", IEEE Global conference on signal and information processing, Orlando, 2015.
- [12] Jin-De Zhu, Chin-Feng L. et al. "Analysis of spike waves in epilepsy using Hilbert-Huang transform", *Journal of Medical Systems* , 2015.
- [13] Kshischang F. R."The Hilbert transform",University of Toronto, 2006.
- [14] Herrmann C.S., Grigutsch M., Bush N.A. "EEG oscillations and wavelet analysis",*Event-related potencial*,2005.
- [15] Shaiens J."A tutorial on Principal Analysis", arXiv preprint, Cornell University, 2014.