

# High-performance FPGA Architecture for Data Streams Processing on Example of IPsec Gateway

Mateusz Korona, Krzysztof Skowron, Mateusz Trzepinski, and Mariusz Rawski

**Abstract**—In modern digital world, there is a strong demand for efficient data streams processing methods. One of application areas is cybersecurity — IPsec is a suite of protocols that adds security to communication at the IP level. This paper presents principles of high-performance FPGA architecture for data streams processing on example of IPsec gateway implementation. Efficiency of the proposed solution allows to use it in networks with data rates of several Gbit/s.

**Keywords**—IPsec, FPGA, hardware implementation, data streams processing

## I. INTRODUCTION

ALONG with dynamic development of telecommunication and multimedia in recent years, a strong demand for efficient methods of data streams processing has emerged. Cybersecurity is one of important areas, where they are utilized. Data on the Internet are transmitted through multiple routers and may be intercepted (*packet sniffing*). Cybercriminals use also active attack methods, consisting of packet forging (*packet spoofing, man in the middle*). Information is at risk not only on the Internet — proper internal network perimeter security is necessary. Economic globalization and necessity of e-business profits protection prompted creation of adequate safety mechanisms.

Internet of Things (verification and processing of data from various sensors), wireless communication and video streams processing (transcoding, multiscreen applications) are other areas, where effective data streams processing systems can be applied.

This paper describes the idea of hardware architecture for high-performance data streams processing in FPGA on example of IPsec gateway, which offers all features of IPsec protocol suite and is efficient enough to be used in networks with data rates of several Gbit/s.

Section II. presents fundamentals of IPsec protocol suite. In section III. prototype of IPsec gateway is described and possible areas of its improvement are mentioned. Section IV discusses the principles of high-performance architecture of completely functional IPsec gateway and its potential is analyzed in section V. Section VI describes some other possible applications of developed architecture. Section VII concludes the paper.

Authors are with the Institute of Telecommunications, Faculty of Electronics and Information Technology, Warsaw University of Technology, Poland (e-mail: rawski@tele.pw.edu.pl).

## II. IPSEC STRUCTURE

Internet Protocol Security (IPsec) is network protocol suite that protects communication over IP protocol. Its subprotocol ESP (*Encapsulating Security Payload*) provides confidentiality, integrity and authenticity of transmitted data.

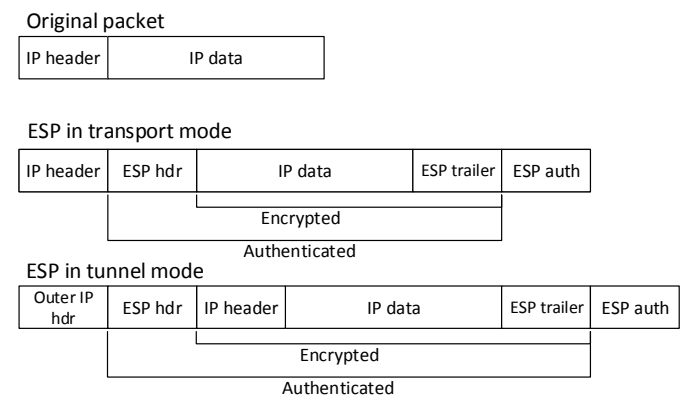

Fig. 1. IP packet secured with ESP protocol (transport and tunnel mode of operation). Source: [amaranten.com](http://amaranten.com)

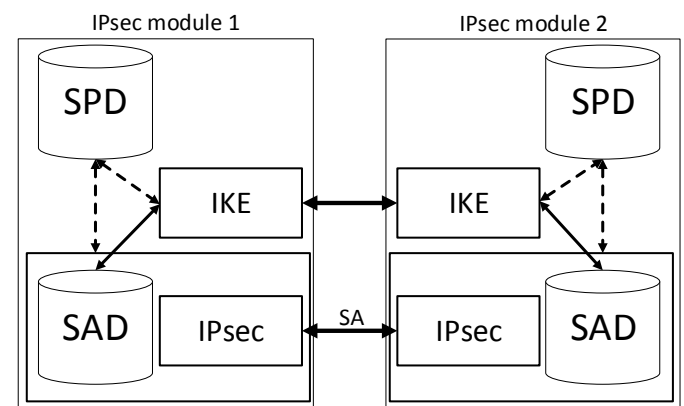

Fig. 2. Architecture of IPsec system. Source: [codeidol.com](http://codeidol.com)

Tunnel operation mode (fig. 1) allows for creation of VPN networks. Original packet must be properly padded, so it can be encrypted with block cipher (total message length must be multiple of cipher's block length). Padding contains also part of the ESP protocol header (*ESP trailer*). Then packet is ciphered and ESP header (*ESP hdr*) is added. It consists of two fields: Security Parameter Index and Sequence Number. First one is identifier of SA (*Security Association*) — logical connection between two network devices with set of cryptographic attributes shared by them (e.g. cipher key) and the

latter is countermeasure against replay attacks. At the end ICV (*Integrity Check Value*) is appended (*ESP auth*, e.g. *keyed-hash Message Authentication Code* – HMAC hash). After recalculation of this value integrity and authenticity of the packet can be verified. Finally, outer IP header is attached.

Fig. 2 presents the architecture of IPsec system. *Security Policy Database* is reflection of corporate security policy. SPD stores selectors (e.g. IP addresses, port numbers, etc.), which are used by gateway to decide, whether (and possibly how) each particular packet should be protected. *Security Association Database* stores information necessary to secure packet (e.g. encryption key). *Internet Key Exchange* module is responsible for negotiation and automatic setup of new safe channels (*Security Association*). Module marked as IPsec performs all cryptographic operations and packet encapsulation.

There is a variety of available IPsec solutions. *Open source* software implementations are suitable only for private use (e.g. Linux OpenWRT distribution [1], designed for home routers, which offers throughput of the order of several dozen Mbit/s). More efficient solutions require significant hardware resources (over a dozen processing cores) to achieve maximal throughput of 1 Gbit/s (strongSwan project [2][3]). Commercial implementations often use hardware support (e.g. Intel IPsec library designed for Intel Architecture processors with extended instruction set [4]). These solutions offer higher throughputs (of the order of several Gbit/s, [5][6]), but are expensive. There are commercial implementations of IPsec using FPGAs [7] or GPUs [8], but they don't provide all IPsec features (e.g. IP traffic header processing or any IPsec database functions).

### III. PROTOTYPE DESIGN

Original goal of this paper authors was to develop IPsec gateway, that implements all stages in FPGA and maximizes benefits of hardware packet processing, in contrast to other solutions that use hardware only for critical functions acceleration. Solution was split into hardware data plane and software control plane (including IKE module).

A prototype of IPsec gateway was designed [9] and its analysis allowed to elaborate guidelines for next generation product and generic efficient data streams processing architecture.

#### A. Prototype Implementation

Fig. 3 presents the scheme of packet-securing part of the design (AST is abbreviation of AXI4-Stream interface). After packet reception in Ethernet controller and when data link layer header is stripped, pure IP packets are moved to simple security policy controller. Pearson's hash is calculated from IP header selectors, which is key in SPD database and allows to find appropriate records. This module determines whether data must be secured or can be transmitted through *bypass* path. The entire data securing process is carried out in *IPsec\_outbound* module. Subsequent processing steps are: SAD database lookup to fetch particular SA attributes, ESP encapsulation and DES encryption. The last step is SHA1-based HMAC calculation and packet is stored in FIFO until it is appended.

#### B. Prototype Performance Analysis

Prototype of IPsec gateway was tested with Terasic DE2-70 developer board equipped with Altera's Cyclone II FPGA. Maximum clock frequency of the design was 86.72 MHz with 20% FPGA logic utilization.

$$R_b \left[ \frac{\text{Mbit}}{\text{s}} \right] = \frac{8 \cdot N \left[ \frac{\text{bytes}}{\text{packet}} \right]}{M \left[ \frac{\text{cycles}}{\text{packet}} \right]} \cdot F \left[ \text{MHz} \right] \quad (1)$$

Using formula 1, where  $N$  – size of the packet,  $M$  – number of cycles necessary for packet processing,  $F$  – maximum clock frequency of the design, throughput of the IPsec gateway for several packet lengths was computed (table I).

TABLE I  
IPSEC GATEWAY PROTOTYPE PERFORMANCE

Packet size [byte]	Cycles/packet	$R_b$ [Mbit/s]
64	520	85.39
240	784	209.70
1500	2682	437.44

The correctness of prototype operation was verified with functional simulation and tests including packet generator and sniffer (Ostinato and Wireshark respectively). Prototype

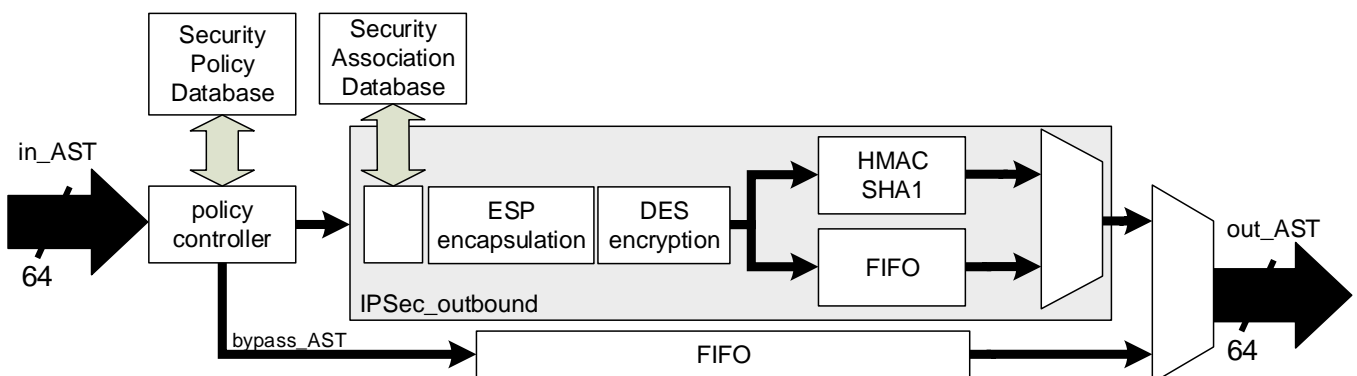

Fig. 3. Block diagram of the prototype

performance analysis allowed to identify three key elements critical for throughput increase.

The main "bottleneck" of the prototype is the module responsible for HMAC hash calculation. HMAC algorithm requires that SHA-1 digest is computed twice — for 240-byte IP packet it takes 86% time of its processing (685 cycles of total 794).

Another problem is the design of security processor — IPsec functions are divided between security policy controller and complex module performing all other operations. During HMAC hash calculation stage, which is the longest one in the whole process, resources responsible for IP and ESP encapsulation or data encryption remain unused.

On the other hand, low FPGA logic utilization (20%) of small by today's standards Cyclone II FPGA allows for application of hardware optimization methods, such as pipelining and parallelization of the processing.

#### IV. IPSEC GATEWAY 2.0

The prototype analysis became the basis for development of new hardware IPsec gateway architecture. Advanced hardware optimization methods were applied for its implementation, leading to increase in processing speed and better logic utilization (fig. 4).

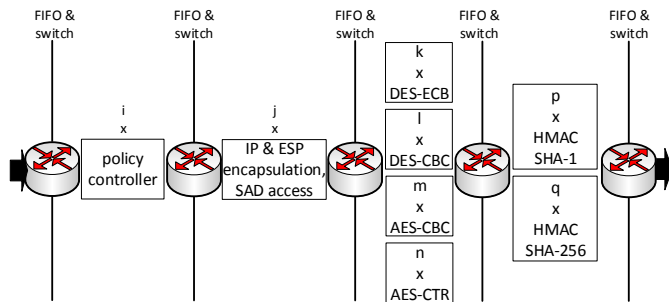

Fig. 4. New IPsec gateway concept

As it was mentioned in section II, processing of ESP protocol consists of several suboperations that can be performed independently. The only requirement is that they must be subsequent for a particular packet, but couple of packets can be processed simultaneously. The IPsec functions were therefore divided into several sections of the design. What is more, every section can contain many modules implementing a specific stage of processing, working in parallel. Sections are separated with FIFO queues and *round robin* switches, which distribute packets between modules in particular section. As a result, even more packets can be processed at the same time. The utilization of switches enables controlling the load of processing elements in given section. Increasing the number of modules calculating the most time-consuming HMAC resulted in throughput increase. Simplified application of many different cryptographic algorithms (e.g. several ciphers in various modes in ciphering section) is also great advantage of presented architecture.

##### A. Internal Packet Header

New architecture concept allowed to vastly increase throughput of the IPsec gateway, however a problem of sharing *Security Association* attributes among modules in particular sections arose. In the prototype (fig. 3) *Security Association Database* is accessed by one complex module, which performs also all other IPsec functions, but in IPsec gateway 2.0 packet processing is distributed. Fetching SA attributes in every single module would be huge load for the database and would be extremely inefficient. Therefore it was decided that database accesses will be performed in separate gateway section and all the information will be transmitted *along* with the packet. Fig. 5 presents structure of internal packet header before given modules in IPsec gateway sections, which is transported using *TUSER* sideband signal of AMBA AXI4-Stream [10] interface together with IP data.

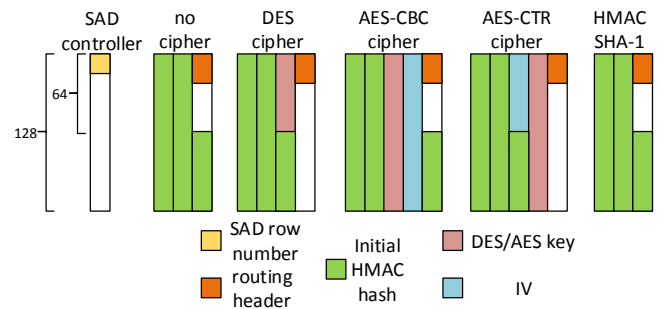

Fig. 5. Internal packet header structure for various cryptographic algorithms

Packet, which was directed for securing in security policy controller, has a pointer to specific *Security Association Database* row. After SAD access section all headers contain *routing field* with information about next destination modules (e.g. packet must be ciphered in AES-CBC module and ICV at HMAC-SHA1 module must be appended). Packets before encryption section (except the situation when no cipher is applied) have ciphering key and other information depending on cipher operation mode [11][12] attached. Fig. 5 shows also how the internal header is changed between sections — after ciphering section all data necessary for encryption are stripped and before HMAC section header contains only initial HMAC hash values.

##### B. Packet Switch

Packet switch is the crucial element of this high-performance and configurable architecture. It relays packets basing on information from internal header and works as load-balancer.

Concept of packet switch implementation is illustrated in fig. 6. Module has  $N$  inputs connected to long FIFOs — these are actual packet buffers. FIFOs connected to  $M$  outputs are short, because they must buffer only one packet, which is currently being processed by destination module.

Switch contains also two internal sets of FIFOs — *queue* and *type*, respectively. First one allows to register all incoming packets with given destination address (in fact destination module type). Number of output connected to module of given

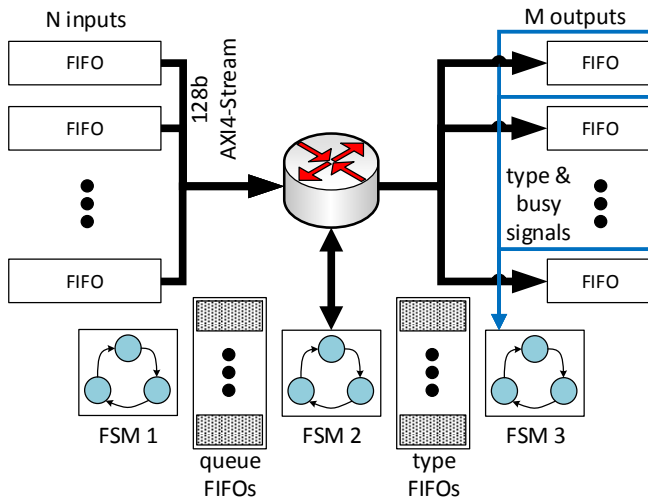

Fig. 6. Packet switch scheme

type, which is ready to process next packet, is stored in the second FIFO set.

Finite-state machine 1 (FSM1) controls *queue* FIFO set. It periodically checks input FIFOs and whenever one contains valid data, destination module type is read from *routing header* and number of this input is written into *queue* FIFO assigned to this type.

FSM3 is responsible for *type* FIFO set. It periodically reads *type* and *busy* control inputs and whenever destination module signalizes its availability, number of this output is written into *type* FIFO assigned to this type.

The most important function is performed by FSM2. It monitors outputs of *queue* FIFO set and when it finds valid data, it checks appropriate FIFO from *type* set (where information about availability of desired destination module is stored). If free resource is found, FSM creates connection between input and output and packet is transmitted.

*Routing header* may be also potentially used to distinguish between traffic classes within the design. Some modules in given section can be designated only to process high-priority traffic (e.g. part of AES-CBC encryption modules). Separate *type* identifier must be assigned to them and then it must be included in *routing header* of high-priority packets.

### C. HMAC-SHA1 Module Optimizations

In order to improve performance of IPsec gateway, optimizations of individual modules were also performed. Special attention was devoted to HMAC-SHA1 module, because its efficiency was the crucial processing speed curtailment in the prototype. Fig. 7 presents HMAC algorithm [13].

SHA-1 hash is calculated from IP packet with prepended *i\_key\_pad* value. String of bits is split into 512-bit blocks, which are processed individually by hash algorithm. In the second stage, *o\_key\_pad* value is prepended to previously calculated hash and the whole procedure is repeated. Finally, 160-bit HMAC hash is obtained, ready to be appended to the secured packet. *I\_key\_pad* and *o\_key\_pad* blocks are the result

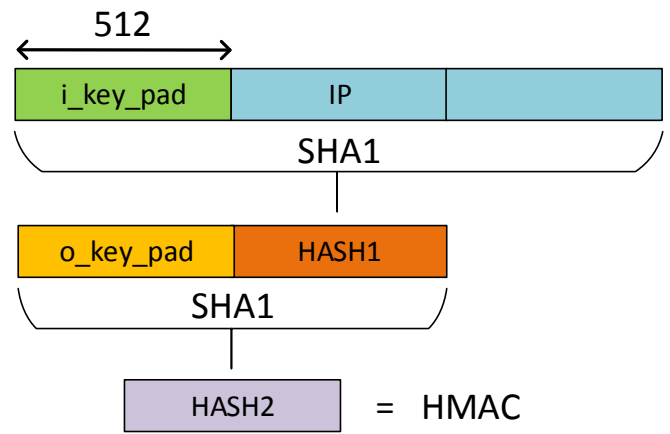

Fig. 7. HMAC-SHA1 algorithm scheme

of XOR operation performed on the key and two constants defined in RFC 2104 [13].

The same key is used for all IP packets being secured by one SA channel. This means that SHA-1 hashes of blocks *i\_key\_pad* and *o\_key\_pad* can be calculated in advance, right after SA negotiation process and stored in *Security Association Database* instead HMAC key. SHA-1 submodule in HMAC-SHA1 processor has only to be initialized with these precalculated values during ICV calculation — they are included in internal packet header (fig. 5). This optimization shortens the HMAC calculation by 160 clock cycles (processing time of two 512-bit blocks in SHA-1 algorithm before further optimizations – in IPsec gateway prototype).

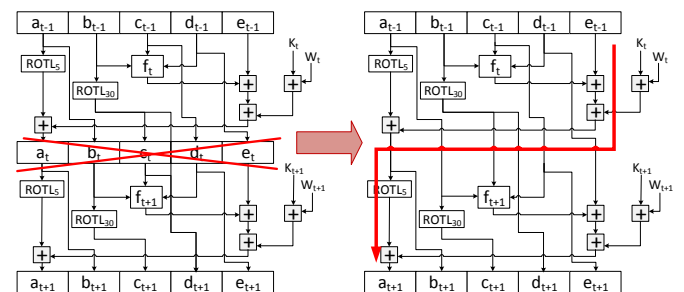

Fig. 8. SHA1 algorithm unfolding – critical path problem. Based on: [15]

Another important task is reduction of time required for 512-bit block processing in SHA-1 algorithm [14]. Unfortunately, hardware algorithm's loop unrolling (e.g. calculation of 2 of 80 rounds in one clock cycle) results in the extension of the design's critical path (fig. 8), because extra addition must be performed during the same clock cycle. This leads to the decrease of design maximum frequency.

The solution of this problem was proposed in paper [15]. SHA-1 algorithm was modified by adding new variables — some calculations can be moved one round earlier than in unmodified algorithm, because their inputs are already known (values derived from previous round). That way extra addition can be avoided when unrolling the algorithm's loop. Implementation of the improved algorithm decreased the time of the 512-bit block processing to 40 clock cycles (from the

initial 80) without causing a drop in the design's maximum frequency.

#### D. Other Architecture Optimizations

The width of the internal bus was increased from 64 to 128 bits (size of the AES block) in order to improve the performance. Two parallel DES pipelines (64-bit width) were placed in DES-ECB ciphering modules.

The use of many parallel processing cores created a problem in providing access to Security Association Database. To solve this, appropriate arbiter system was designed. Moreover, the accesses to the database were moved to a separate clock domain, because the DDR memory can usually be clocked with much higher frequency than other design parts.

### V. PERFORMANCE ANALYSIS

The design was tested with new Terasic DE5-Net developer board equipped with Altera's Stratix V FPGA. Synthesis of the IPsec gateway in various configurations (with varying number of particular modules in the gateway sections) was conducted. Table II presents synthesis results for DES configurations. In the *Configuration* column, numbers of security policy controllers, SAD controllers, ciphering modules and HMAC modules in every section were listed respectively.

TABLE II  
DESIGN IMPLEMENTATION RESULTS FOR DES CONFIGURATIONS

Configuration	$F_{max}$ [MHz]	Logic utilization
4/4/4/4	102.79	16%
4/4/4/8	104.04	20%
8/8/8/16	100.65	38%

The same throughput estimation method as in the prototype was used to compute the throughput of every configuration. It must be noted that benefits of the new architecture are visible when packet stream is being processed. In tables III, IV and V, throughput (Mbit/s) for miscellaneous packet streams is presented.

TABLE III  
THROUGHPUT FOR 64-BYTE PACKETS

Configuration	Count of packets in stream			
	16	32	64	128
4/4/4/4	1137.91	1253.06	1319.84	1355.97
4/4/4/8	1691.06	2029.28	2254.75	2387.38
8/8/8/16	1940.06	2780.86	3550.16	4120.05

TABLE IV  
THROUGHPUT FOR 240-BYTE PACKETS

Configuration	Count of packets in stream			
	16	32	64	128
4/4/4/4	2363.55	2526.17	2616.16	2663.61
4/4/4/8	3699.20	4342.54	4756.11	4979.33
8/8/8/16	4218.24	5784.79	7103.89	<b>8018.07</b>

TABLE V  
THROUGHPUT FOR 1500-BYTE PACKETS

Configuration	Count of packets in stream			
	16	32	64	128
4/4/4/4	3239.63	3403.22	3478.30	3526.33
4/4/4/8	6139.47	7168.50	7732.62	8081.76
8/8/8/16	6185.03	7975.65	9291.33	<b>10227.44</b>

Similar tests were conducted for IPsec gateway using AES block cipher in CBC mode, which is more advanced than DES. Because the most time-consuming part in this configuration is the ciphering process, the number of ciphering modules in section was increased. Table VI presents synthesis results for AES configurations, while design throughput for miscellaneous packet streams is shown in tables VII, VIII and IX.

TABLE VI  
DESIGN IMPLEMENTATION RESULTS FOR AES CONFIGURATIONS

Configuration	$F_{max}$ [MHz]	Logic utilization
4/4/6/4	94.07	27%
8/8/12/8	97.98	34%

TABLE VII  
THROUGHPUT FOR 64-BYTE PACKETS

Configuration	Count of packets in stream			
	16	32	64	128
4/4/6/4	830.411	973.01	1064.39	1116.84
8/8/12/8	1254.14	1658.37	1976.98	2187.06

TABLE VIII  
THROUGHPUT FOR 240-BYTE PACKETS

Configuration	Count of packets in stream			
	16	32	64	128
4/4/6/4	1711.98	1990.24	2166.29	2266.53
8/8/12/8	2537.90	3355.57	4056.53	4424.76

TABLE IX  
THROUGHPUT FOR 1500-BYTE PACKETS

Configuration	Count of packets in stream			
	16	32	64	128
4/4/6/4	2598.65	2755.95	3032.10	3076.89
8/8/12/8	3362.10	4580.40	4961.40	<b>5518.80</b>

### VI. POSSIBLE APPLICATIONS OF DEVELOPED ARCHITECTURE

Hardware acceleration of data processing is widely used nowadays and therefore there are many possible application areas of presented architecture. Authors discuss some of them.

#### A. Intrusion Detection/Prevention System

Intrusion Detection System is a device that monitors network for malicious activity (using signature-based and

anomaly-based methods) and alarms network administrator whenever something suspicious is detected. Intrusion Prevention System is extended version of IDS — besides standard functionality, it is capable of blocking detected attacks. Network traffic is split into *flows* to allow its analysis. Each of them is identified with set of values (e.g. IP address, port numbers, data from application layer headers, etc.).

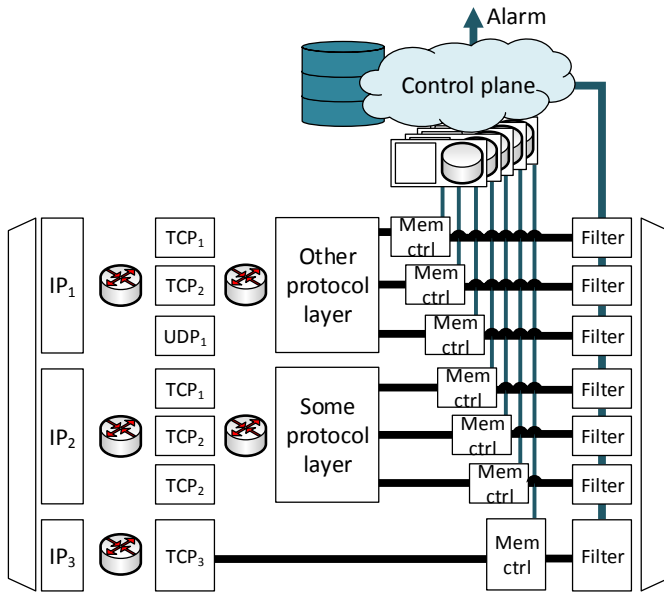

Fig. 9. Block diagram of Intrusion Prevention System

Concept of IPS implementation is illustrated in fig. 9. Stages of data processing were divided into sections as in IPsec gateway. At first packets are sorted in several layers corresponding to network protocol stack, in order to create group of flows that share some common features. This divides main task to subproblems and moreover allows for load balancing of subsequent section (*Memory controllers*), which is responsible for counting packets belonging to given flows and storing this information in databases. Software control plane analyzes gathered data and should detect possible threats. If necessary it alarms network administrator (IDS responsibility), but also configures set of packet filters at the end of the device to prevent malicious packets from entering the network.

### B. Wireless Communication

Another area, where presented architecture could be used, is wireless communication. Radio channel characteristic and its high variability enforces application of various checksums and forward error correction methods along with adaptive coding and modulation.

Fig. 10 presents simplified, generic diagram of wireless transmitter (based on [16]). Multiple video streams can be data to transmit. At first stream configuration must be performed — initial configuration is read from the database and can be modified by device control plane depending on radio channel condition (ACM). In subsequent sections CRC is calculated and redundant bits are added (there can be more than one FEC

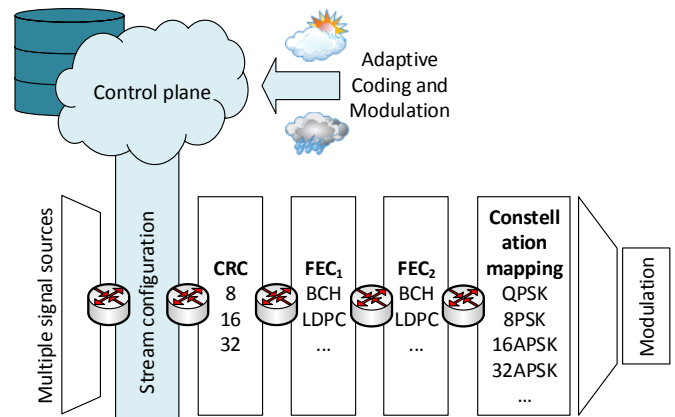

Fig. 10. Block diagram of simplified wireless transmitter

layer). At the end constellation mapping is done and packet is transmitted.

## VII. CONCLUSION

This paper presents high-performance and configurable FPGA architecture for data streams processing and process of its formation during hardware implementation of IPsec gateway in FPGA. Thanks to the use of advanced designing methods and the optimization typical for digital circuits implementation, high processing speed was achieved. Created device can compete with commercial IPsec solutions, especially these implemented in FPGA [7]. Architecture of this design is strong basis for future hardware accelerators implementations.

## REFERENCES

- [1] OpenWRT project webpage, *IPsec performance*, accessed 26.03.18, <https://wiki.openwrt.org/doc/howto/vpn.ipsec.performance>
- [2] strongSwan project webpage, accessed 26.03.18, <https://www.strongswan.org/>
- [3] Klassert Steffen, *Parallelizing IPsec*, [https://www.strongswan.org/docs/Steffen\\_Klassert\\_Parallelizing\\_IPsec.pdf](https://www.strongswan.org/docs/Steffen_Klassert_Parallelizing_IPsec.pdf), 2010
- [4] Intel Corporation, *Fast Multi-buffer IPsec Implementations on Intel Architecture Processors*, 2012
- [5] Cisco Systems, Inc., *Cisco IPsec and SSL VPN Solutions Portfolio*, 2008
- [6] Juniper Networks, *Security Products Comparison Chart*, 2015
- [7] Helion Technology Limited, *IPsec ESP IP Core for FPGA – Product Brief*, accessed 26.03.18, <http://www.heliontech.com/ipsec.htm>
- [8] Sangjin Han, Keon Jang, Kyoung Soo Park, Sue Moon, *PacketShader: a GPU-accelerated Software Router*, <http://shader.kaist.edu/packetshader>, 2010
- [9] Mateusz Korona, *Implementation of IPsec protocol suite using field-programmable devices*, bachelor thesis, 2015
- [10] ARM, *AMBA 4 AXI4-Stream Protocol Specification*, 2010
- [11] Frankel S., Glenn R., Kelly S., RFC-3602, *The AES-CBC Cipher Algorithm and Its Use with IPsec*, 2003
- [12] Housley R., RFC-3686, *Using Advanced Encryption Standard (AES) Counter Mode With IPsec Encapsulating Security Payload (ESP)*, 2004
- [13] Krawczyk H., Bellare M., Canetti R., RFC-2104, *HMAC: Keyed-Hashing for Message Authentication*, 1997
- [14] Eastlake D. 3rd, Jones P., RFC-3174, *US Secure Hash Algorithm 1 (SHA1)*, 2001
- [15] Eun-Hee Lee, Seok-Man Kim, Chungbuk National University, *Design of High Speed SHA-1 Architecture Using Unfolded Pipeline for Biomedical Applications*, accessed 26.03.18, <http://www.iiis.org/CDs2009/CD2009SCI/SCI2009/PapersPdf/S231IM.pdf>
- [16] ETSI, EN 302 307 v. 1.1.2, *Digital Video Broadcasting (DVB); Second generation framing structure, channel coding and modulation systems for Broadcasting, Interactive Services, News Gathering and other broadband satellite applications*, 2006