

Minimizing Delay Using Dynamic Blocking Expanding Ring Search Technique for Ad Hoc Networks

Kavita Mhatre, and Uday Khot

Abstract—Energy and latency are the significant Quality of Service parameters of ad hoc networks. Lower latency and limited energy expenditure of nodes in the ad hoc network contributes to a prolonged lifetime of the network. Reactive protocols determine the route to the destination using a route discovery process which results in increased delay and increased energy expenditure. This paper proposes a new technique of route discovery, Dynamic Blocking Expanded Ring Search (DBERS) which minimizes time delay and energy required for route discovery process. DBERS reduces energy expenditure and time delay occurring in the existing route discovery techniques of reactive protocols. The performance of DBERS is simulated with various network topologies by considering a different number of hop lengths. The analytical results of DBERS are validated through conduction of extensive experiments by simulations that consider topologies with varying hop lengths. The analytical and simulated results of DBERS are evaluated and compared with widely used route discovery techniques such as BERS, BERS+. The comparison of results demonstrates that DBERS provides substantial improvement in time efficiency and also minimizes energy consumption.

Keywords—AODV, BERS, ERS, BERS+, DBERS, MANET, Latency, Energy efficiency, Route discovery

I. INTRODUCTION

MANET is a collection of nodes which interact with each other without a fixed base station or access point. Nodes in MANET [1] can route their packets to neighbouring nodes without any physical infrastructure. Nodes are battery operated and hence saving energy is utmost important for a longer lifetime of the ad hoc network [2]. Protocols used for MANET [3] define the communication between the nodes. Reactive protocols work on-demand basis [4]. Whenever any node requires a path to the particular destination node, the route is found on demand and route is established between source and destination. Most popular reactive protocol AODV works in a similar way. AODV broadcasts the packet to neighboring nodes. If the destination is located, RREP is sent back to the source. If the destination is not found, neighboring nodes rebroadcast the same packet to their neighboring nodes [5]. The procedure repeats until the destination is found. To decrease energy consumption during packet transmission and to decrease time required for locating the destination, existing algorithms need to be further modified to achieve an increased time efficiency and energy efficiency of an ad hoc network. Main contributions of paper are

1. This article identifies the unnecessary fixed waiting time

Kavita Mhatre is with Usha Mittal Institute of Technology, SNDT Women's University, Mumbai, India (e-mail:-kavitamhatre@yahoo.com).

Uday Khot is with St. Francis Institute of Technology, Mumbai University, Mumbai, India (e-mail:-udaypandit@rediffmail.com).

utilized in existing broadcasting techniques to receive reply from neighboring nodes resulting in increased latency and energy expenditure. To overcome these drawbacks, the paper defines the new process of route discovery, DBERS.

2. DBERS aims at identifying and reducing the unnecessary waiting time. It is done by introducing dynamic waiting time to receive response from intermediate nodes instead of fixed waiting time in existing broadcasting techniques implemented for MANET.

3. The new technique DBERS improves substantial increase in time efficiency to locate the destination compared with the existing route finding techniques. At the same time, it also requires less energy to find the destination compared to widely used route discovery techniques such as BERS, BERS+. The paper is organized as follows. In this paper, section II describes existing route discovery techniques like ERS, BERS, BERS+, tBERS and tBERS*. System model is illustrated in section III. New proposed method is introduced in section IV. Simulation results and its analysis are presented in section V. Validation of DBERS is demonstrated in section VI. Conclusions are drawn in section VII.

II. RELATED WORK

Reactive protocols like AODV, DSR produce excessive energy consumption, increased bandwidth and delay in route discovery process [6]. Energy efficient algorithm for AODV is proposed in [7] to reduce energy dissipation of network. Hence, modified AODV protocol [8,9] can be used to minimize flooding of route request packets. Broadcasting technique aims at reducing bandwidth requirements of MANETs. Ring search techniques mentioned below are also implemented to reduce redundancy of broadcasting RREQ packets.

ERS Expanding Ring Search (ERS) is employed for flooding of route request packet to locate the destination node in the network. ERS reduces energy expenditure of routing protocols effectively.

TTL mechanism is used in ERS [10] for searching the path to the destination as shown in the Fig. 1. TTL value (k) determines the flooding areas. Initially, RREQ is flooded in the region with a radius of k hops. If RREP from the destination is not obtained, TTL value is increased and the same procedure is repeated until the destination is located [11]. ERS enhances energy efficiency and decreases control overhead compared to AODV. If the distance between destination and source is more, source rebroadcasts same RREQ packet to intermediate nodes. Thus, these nodes have to process the same RREQ packet many times. This leads to a lot of energy dissipation of intermediate nodes and increased control overhead in the network. Hence, ERS is not suitable when the destination node



is to be found in the entire network. ERS wastes energy by re-flooding RREQ packets redundantly.

BERS BERS is another technique of route discovery of destination node studied in [12] for MANETs. In BERS approach, source node doesn't reinitiate flooding mechanism again and again even if the destination is not found. BERS decreases overhead and energy expenditure. Initially, the source node broadcasts an RREQ packet within a specified region or ring. If the destination is not found, the intermediate nodes in that ring rebroadcast RREQ packet instead of the source node. Rebroadcasting of RREQ packet is initiated by the intermediate nodes. Rebroadcasting is done till the next ring or specified region. Intermediate nodes wait for RREP for twice of hop (H) time. H is the hop number. If the destination is found, RREP is sent to the source. Source node stops every intermediate node from further flooding and processing of packets by sending End instruction. The time efficiency is further increased by identifying unnecessary waiting time caused by END instruction.

BERS+ BERS+ minimizes total energy consumption while defining a path to the destination from the source. This algorithm presents minimum energy approach and also minimized latency. The source will broadcast RREQ only once. It will be further received by intermediate nodes in the first ring. If the destination is not found from intermediate nodes within the specified waiting time in the first ring, intermediate nodes will further rebroadcast it to the nodes in the second ring. Intermediate nodes will wait only for one hop time to receive RREP or before rebroadcasting [13]. This will reduce delay and overall energy required for locating destination compared to AODV protocol. BERS+ saves time needed for finding the path compared to ERS and BERS techniques.

Time Efficient BERS (tBERS and tBERS*) The working of tBERS and tBERS* is described in [14]. The tBERS works similar to BERS. The only difference between two is STOP instruction. The STOP/END instruction can be issued by destination or route node in tBERS whereas it can be issued only by a source node in BERS after receiving route reply from route node in the network. Allowing route node to issue STOP/END instruction minimizes latency in tBERS compared to BERS without increasing energy consumption. Similarly, tBERS* allows route node to broadcast STOP/END instruction to minimize latency. The latency increases while finding destination is mainly because of unnecessary waiting time employed in tBERS, tBERS*, BERS, BERS+. A substantial reduction in latency can be obtained by using dynamic waiting time in route discovery process. Newly proposed technique DBERS employs dynamic waiting time which is proportional to node density and it helps to overcome shortcomings of existing broadcasting controlled techniques.

III. SYSTEM MODEL

The product model described in [15] is used to find the broadcasting cost in MANET which is given by equation (1).

$$C(x) = E_t(x) T_r(x) \quad (1)$$

where x is the size of the input data. $E_t(x)$ is the total energy consumed. $T_r(x)$ is the time it takes to complete route discovery.

If $E_{ta} = E_{tb}$, then $T_{ra} = T_{rb}$. In this case, if energy efficiency of approach a is equal to energy efficiency of approach b, then both approaches will show equal time efficiency.

If $E_{ta} \neq E_{tb}$, then $T_{ra} \neq T_{rb}$. In this case, if energy efficiency of approach a is not equal to energy efficiency of approach b, then time efficiency of approach a will not be equal approach b.

IV. PROPOSED SCHEME DBERS

This section details about newly proposed DBERS technique. The Fig.3 shows flowchart of DBERS approach. This section also presents theoretical analysis of time delay or latency introduced in route discovery process to locate destination. It also demonstrates mathematical equation to calculate amount of energy consumed in process of route discovery.

A. DBERS

The important difference among BERS, BERS+ and DBERS are waiting time. Waiting time is kept to fixed or defined value in BERS, BERS+. In DBERS, waiting time is not fixed. It is dynamic and waiting time is proportional to node density in DBERS. Intermediate nodes in DBERS will not wait for the fixed amount of waiting time like in BERS or BERS+ to receive RREP or before rebroadcasting RREQ. When a source has a data packet to transmit it to the destination, the density of neighboring nodes of the source is estimated. The waiting time depending upon the density of neighboring nodes of source (an average number of nodes in neighborhood of source) is computed and then RREQ packet is broadcasted. The node density considered in this paper is based on number of nodes found in given area and the connectivity of nodes. The connectivity of nodes depends upon the transmission range of each node. In this paper, the waiting time is made proportional to node density in the neighborhood of the source or average no of nodes in the neighborhood of the source which is computed by equation (2).

$$N_{avg} = \frac{N_{source}}{N_{total}} \quad (2)$$

where N_{avg} = Average no of nodes in the neighborhood of source, N_{source} = No of nodes in the neighborhood of source, N_{total} = Total no of nodes.

The source will broadcast the RREQ packet to neighboring nodes in the first ring as shown in Fig. 2. The Fig. 3 shows flowchart of DBERS approach. The source will wait for dynamic waiting time to receive a reply from its neighboring nodes in the first ring. If the response is not received within estimated dynamic waiting time, intermediate nodes rebroadcast the received RREQ packet to their neighboring nodes in the second ring. The same process continues until the destination is located. When destination node is found, Route reply packet, RREP will be transmitted to the source node. The source node then sends END instruction to every node in the network to stop the flooding or rebroadcasting of RREQ packets. This technique reduces delay and energy required for locating destination compared to AODV protocol as well as BERS+, ERS techniques. DBERS increases time efficiency compared with BERS+ and ERS. It is difficult to achieve a

balanced tradeoff between time and energy parameters (QoS) of ad hoc network. DBERS addresses new combined measure that takes into consideration both energy consumption and time delay. It minimizes time delay of the entire route discovery process and also reduces energy consumption.

B. Analysis of Time Required for Locating Destination

The total time required to locate the destination node is the time at which source propagates the RREQ packet to the time at which source receives RREP. The total time to find destination involves broadcasting time and waiting time. The waiting time is the time for the source node or intermediate nodes to receive RREP. If the response is not received within waiting time, intermediate nodes broadcast RREQ packet to the nodes in the next specified area or ring. Therefore, the time taken to find a destination for DBERS is known as End to End Delay.

End to End Delay indicates how long it takes for a packet to travel from source to the destination. It is measured in seconds. The equations (3), (4), and (5) are newly introduced to compute end to end delay for i^{th} range of BERS, BERS+ and DBERS respectively.

$$BERS = 2 * D_{wi} + 2HC * D_{bi} \quad (3)$$

$$BERS+ = D_{wi} + 2HC * D_{bi} \quad (4)$$

$$DBERS = DC * D_{wi} + 2HC * D_{bi} \quad (5)$$

Therefore, the total end to end delay for route discovery for DBERS can be expressed by equation (6)

$$DBERS = (DC * D_{wi} + 2HC * D_{bi}) * k \quad (6)$$

where D_{wi} = Waiting time, HC = Hop Count, k = Total number of hops, DC = DBERS coefficient, D_{bi} = Broadcasting time.

C. Analysis of Energy Consumption

Total energy consumption in DBERS is due to nodes transmitting RREQ and RREP packets, nodes receiving RREQ and RREP packets, and energy expenditure due to idle nodes in MANET. The idle energy consumption is due to the total no of idle nodes in the network for the duration of locating destination (End to End Delay). Therefore, the total energy consumption of BERS, BERS+, and DBERS for one route discovery process is given by equations (7), (8), and (9), respectively.

$$BERS = \sum_{i=1}^k \{E_t * n_{ti} + E_r * n_{ri} + E_{li} * N_{li} * D_{li}\} \quad (7)$$

$$BERS+ = \sum_{i=1}^k \{E_t * n_{ti} + E_r * n_{ri} + E_{li} * N_{li} * D_{li}\} \quad (8)$$

$$DBERS = \sum_{i=1}^k \{E_t * n_{ti} + E_r * n_{ri} + E_{li} * N_{li} * D_{li}\} \quad (9)$$

Where

n_{ti} = Total no of transmitting nodes during broadcasting of the i^{th} range

n_{ri} = Total no of receiving nodes during broadcasting of the i^{th} range

E_t = Energy consumption per node while transmitting the packets during broadcasting of the i^{th} range

E_r = Energy consumption per node while receiving the packets during broadcasting of the i^{th} range

E_{li} = Idle energy consumption per node during broadcasting of the i^{th} range.

D_{li} = End to end ideal delay during broadcasting of the i^{th} range

N_{li} = Total number of ideal nodes per ideal duration during broadcasting of the i^{th} range.

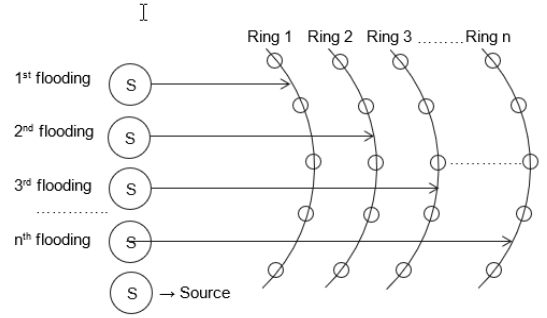

Fig. 1. ERS Approach

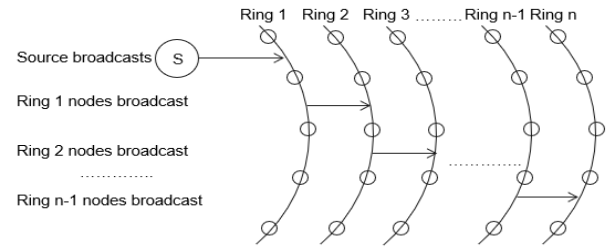

Fig. 2. DBERS Network Topology

V. RESULTS AND DISCUSSIONS (ANALYSIS)

The new algorithm of route discovery is simulated. Simulation runs have been conducted several times using MATLAB simulations to evaluate performance of DBERS and compare it with BERS and BERS+. Simulation environment consists of an area 200×200 m² with uniform distributions of nodes ranging from 80 to 200. Packet size is 512 bytes. Data transmission rate is taken as 1Mbps. Energy consumption while transmitting packets is 100×10^{-9} Joules and energy consumption while receiving data is 100×10^{-12} Joules. Energy dissipation due to idle nodes is same as energy consumption while receiving data. Transmission range of nodes is 25m. Simulations for various performance metrics are conducted with respect to hop-counts. The performance of DBERS is analysed and examined with BERS and BERS+ by considering different performance metrics especially metrics related to latency and energy. Simulations are conducted for different hop lengths to evaluate the performance difference between the new proposed protocol, DBERS, and BERS+, BERS.

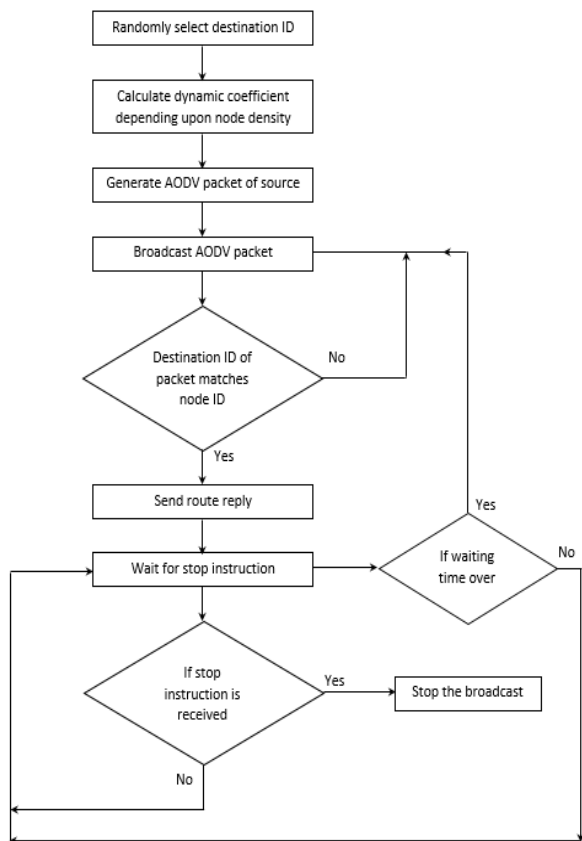

Fig. 3. Flowchart of DBERS Approach

1. End to End Delay End to End Delay describes the amount of time needed for a packet to travel from source to the destination. The Fig. 4 shows that DBERS requires less time to transfer packets to destination compared to BERS and BERS+. The End to End Delay of DBERS goes on decreasing as hop count increases. The efficiency of DBERS is 50.75% in transferring packets to destination for HC=4 and it is 53.84% for HC=5 compared with BERS. The results of Fig. 4 further illustrate that DBERS contributes 27.65% efficiency for HC=4 and 26.66% efficiency for HC=5 higher than BERS+.

2. Average Latency Average Latency = (Packet Arrival - Packet Start)/Total no of packets where Packet Arrival is the time at which packet reaches destination. Packet Start is the time at which source broadcasts the packet. The Fig. 5 shows a comparison of DBERS with BERS+ and BERS with respect to hops. Average latency of DBERS is very less compared to BERS and BERS+. DBERS contributes 49.40% and 32.26% more time efficiency for HC=5 compared with BERS and BERS+ respectively.

3. Energy Exhaustion Ratio Energy exhaustion ratio [16] determines energy used for finding destination node. It is the ratio of the amount of energy expended in the process of locating a destination and the amount of energy available in the network before the start of the ring search method. The Fig. 6 presents that the energy exhaustion ratio of DBERS is less compared to BERS and BERS+ for HC=3 and it is increasing for HC >3. The Fig. 6 shows that energy consumption of DBERS is less than BERS and BERS+ thus

reducing energy requirement and providing time efficiency at the same time.

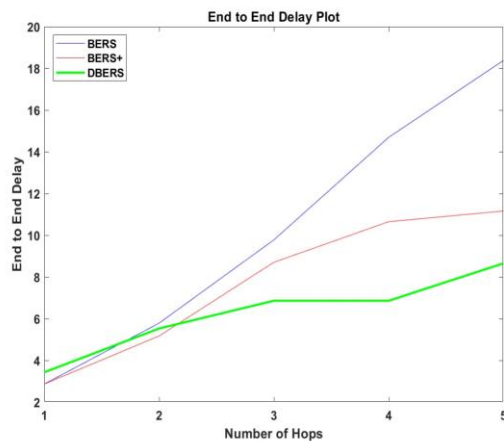

Fig. 4. End to End Delay wrt Hops

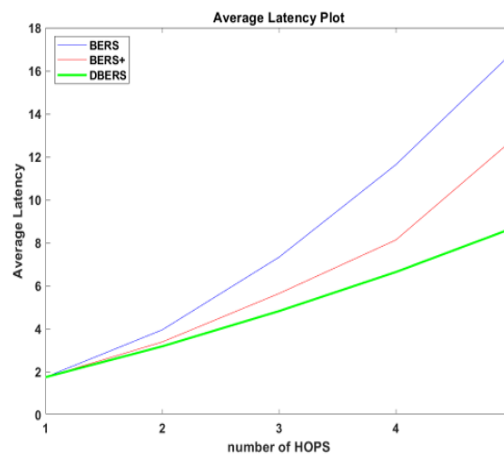

Fig. 5. Average Latency wrt Hops

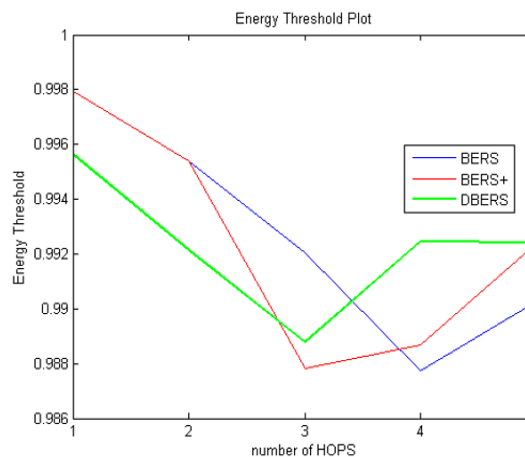

Fig.6. Energy Exhaustion Ratio wrt Hops

4. Query Forwarding It is the ratio of a total number of forwarded RREQ packets (Query packets) to the total number of nodes in MANET. The amount of query forwarding is higher in DBERS compared with BERS+ and BERS as shown in Fig. 7.

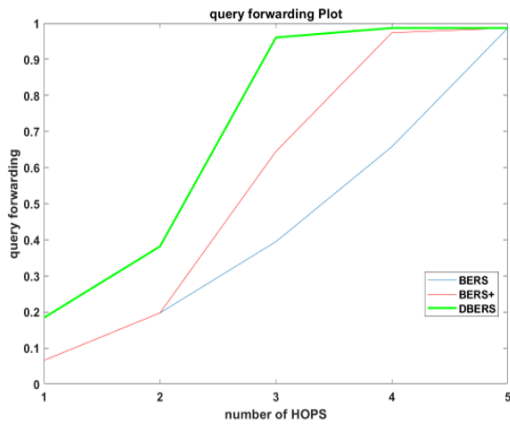

Fig. 7. Query Forwarding wrt Hops

5. Route Request Latency Route Request Latency is defined as the average delay encountered by route request packet per hop from the time source node broadcasts it in the network and until the time chase packet discards it. This time is known as the Route Request Lifetime. The Fig. 8 shows that DBERS provides 50% efficiency over BERS+ for hop count HC=5. DBERS contributes 75% efficiency for HC=5 compared with BERS. Thus DBERS reduces route request latency effectively compared to existing techniques BERS+ and BERS.

VI. VALIDATION

This section presents validation of DBERS results with respect to varying hop lengths. The validation of DBERS performance is also done by simulating experiments numerous times with respect to different hop lengths. Theoretical and simulation results of DBERS, BERS+, and BERS are further compared with each other to analyse performance of DBERS. The performance parameters chosen for validation are end to end delay, average latency, energy exhaustion ratio. Comparison with theoretical and simulated results shown in Figs. 9 to 11 conclude that DBERS performs much better than BERS+, BERS in terms of latency as well as energy consumption.

CONCLUSION

The performance of the newly proposed algorithm DBERS is analysed and evaluated. In this work, the comparison is made in between BERS, BERS+, and DBERS with respect to hop numbers. The performance of DBERS in terms of latency and energy consumption is superior compared to BERS and BERS+. DBERS minimizes energy consumption and latency of route discovery process compared with existing route discovery methods such as BERS and BERS+. Thus, DBERS can contribute good scalability at small expense of overhead. It is therefore well suited for high capacity networks. Furthermore, validation of performance of DBERS is also done through conduction of extensive experiments by simulation considering different network topologies with varying hop lengths. Analytical results and simulated results are evaluated and compared with broadcast controlling existing techniques to prove the performance of DBERS. DBERS

requires less time to transfer packets to destination compared with BERS and BERS+. The End to End Delay of DBERS goes on decreasing as hop count increases. The efficiency of DBERS is 53.84% in transferring packets to destination for HC=5 compared with BERS. The results further illustrate that DBERS contributes 26.66% efficiency for HC=5 higher than BERS+.

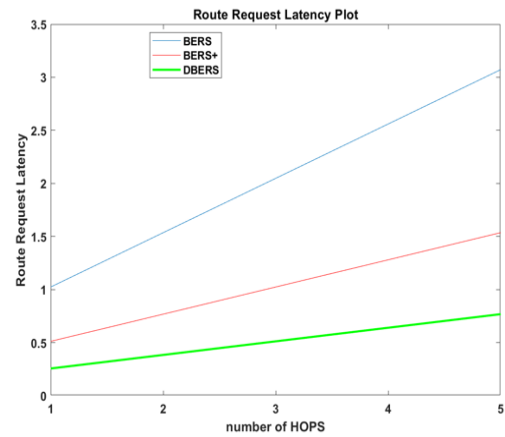

Fig. 8. Route Request Latency wrt Hops

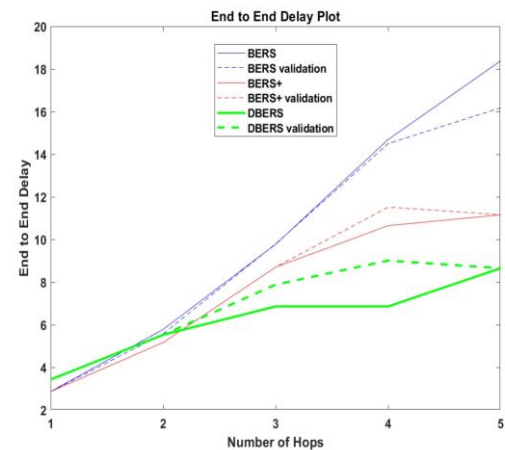

Fig. 9. End to End delay Validation wrt Hops

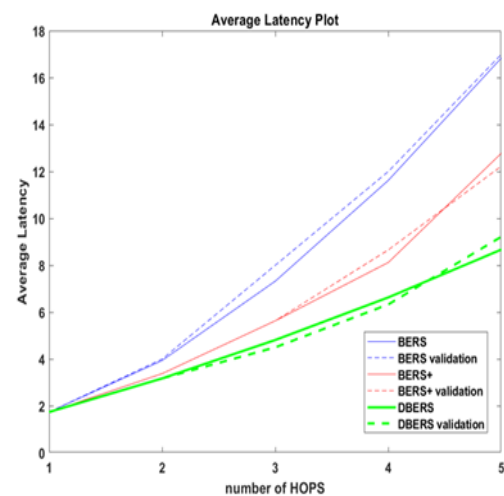

Fig. 10. Average Latency Validation wrt Hops

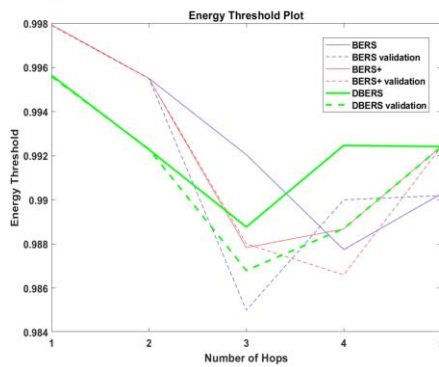

Fig. 11. Energy Exhaustion Ratio Validation wrt Hops

REFERENCES

- [1] S. Singh, S. Dutta, and D.K. Singh, "A study on Recent Research Trends in MANET," *Int. J. Research and Review in Comp. Sci.*, vol.3, no.3, pp. 1654-1657, Jun.2012.
- [2] S. Misra, I. Woungang, and S. C. Misra, "Guide to Wireless Ad Hoc Networks," *J. Sci, Springer Sci and Business Media, USA*, 2009.
- [3] M. Abolhasan, T. Wysocki, and E. Dutkiewicz, "A review of routing protocols for mobile ad hoc networks", *J. Ad Hoc Netw.*, vol.2, no.1, pp. 1-22, Jun. 2004.
- [4] S.A.Ade and PA. Tijare, "Performance comparison of AODV, DSDV, OLSR and DSR routing protocols in mobile ad-hoc networks", *Int. J. Inform. Techno. and Knowl. Mgmt.*, vol.2, no.2, pp. 545-548, Dec.2010.
- [5] J. Moond, D. Singh, and N. Choudhary, "Advancements in AODV Routing Protocol", *Int. J. Compu. Appli.*, pp. 20-25, Sep.2014.
- [6] M. K. Gulati and K. Kumar, "A review of QoS Routing Protocols in MANETs," in *Proc. IEEE Int. Conf. Compu. Commun. and Informatics*, India, Jan.2013, pp. 04-06.
- [7] K. Mhatre and U. Pandit, "Efficient Routing Protocol for MANET", *IEEE Int. Conf. Comput. for Sustainable Global Development (INDIA-Com)*, India, Mar.2016, pp. 1439-1442.
- [8] P. Latha and R. Ramachandra, "Energy Reduction Aware Multicast Routing for Mobile Ad hoc Networks" in *Proc. Indian J. of Sci. and Techno.* vol 3, no.3, pp. 305-307, 2010.
- [9] L. Chao and L. Pingan, "An Efficient Routing Approach as an Extension of AODV Protocol", in *IEEE Future Computer and Commun.*, pp. 95-99, 2010.
- [10] I. Park and I. Pu, "Energy Efficient Expanding Ring Search," *IEEE Proc. of Asia Int. Conf. on Modelling and Simulation*, Thailand, Apr.2007, pp. 198-199.
- [11] Hassan and S. Jha, "On the optimization trade-offs of expanding ring search", in *Proc. of IWDC*, pp. 489-494, Dec.2004.
- [12] I. Park, I. Pu, and J. Kim, "Blocking Expanding Ring Search Algorithm for Efficient Energy Consumption in Mobile Ad hoc Networks", in *Proc. 3rd Annual Int. Conf. on Wireless On-demand Network Systems and Services*, vol.1, Jan.2006, pp. 191-195.
- [13] I. Pu and Y. Shen, "Enhanced blocking expanding ring search in mobile ad hoc networks", in *IEEE Int. Conf. on New Techno., Mobility and Security*, Egypt, Dec.2009, pp. 1-5.
- [14] I. Pu and Y. Shen, "Improving time efficiency in Blocking Expanding Ring Search for Mobile Ad hoc Networks", *J. Discrete Algorit*, vol.24, pp. 59-67, Jan.2014.
- [15] I. Pu and Y. Shen, "Analytical study of Energy-Time efficiency of Blocking Expanding Ring Search", *J. Maths and Comp. Sci.*, vol.3, no.4, pp. 443-456, Jun.2010.
- [16] N. Ahmad and S. Hussain, "Broadcast expenses controlling technique mobile ad-hoc networks: a survey", *J. King Saud Univ. Compu. Inform. and Sci.*, vol. 28, no.3, pp. 248-261, Jul.2016.