

Corona Discharge Based Meters for Manufacturing of Conducting Microwires

Aliya S. Tergeussizova*, Shabden A. Bakhtaev, Waldemar Wojcik, Bekmurza H. Aitchanov,
Gulzada D. Mussapirova, and Aynur Zh. Toygozhinova

Abstract—The wide variety of electrode shapes and their arrangement relative to each other, as well as the possibility of corona discharge in the ambient air, have created prerequisites for the development of a number of new methods and corona discharge transducers designed to measure microwire parameters and linear dimensions of various objects. The principally new non-contact control method is based on the dependence of the corona discharge current value on the diameter of the corona wire placed inside the discharge chamber. This paper provides an overview of this method.

Keywords—corona discharge, measuring method, pulse signal, measuring accuracy, waiting mode

I. INTRODUCTION

THE thin and ultrathin wire (5-100 microns) of various metals and alloys are widely used in the vacuum-electrical and radio engineering industry. The homogeneity of the parameters and the reliability of the electric and radio tubes to a great extent depend on the quality of a tungsten wire which electric characteristics at the constancy of structure of metal are defined, basically, by the geometrical sizes of its section. Therefore, the development of new methods and devices for precise control of the size of microwires under production conditions is of great practical importance.

A large variety of electrode shapes and their location relative to each other, as well as the possibility of corona discharge in ambient air, created the prerequisites for the development of a number of new methods and corona-discharge transducers (CT) designed to measure the parameters of microwire and linear dimensions of various objects [1].

II. METHOD

A fundamentally new method of contactless control is based on the dependence of the magnitude of the corona discharge current on the diameter of the corona wire placed inside the discharge chamber. Depending on the range of diameters of the microwire and the purpose of the measurement, the discharge chamber can have various shapes and sizes. If the electrodes in the form of concentric cylinders are the simplest for determining

the design characteristics, plane-parallel chambers are practically more acceptable, providing the convenience of reloading and centring the wire. Corona-discharge transducers for diameter control in comparison with the known ones have the following advantages: high accuracy, locality of measuring the diameter of the wire, a small error at high winding speeds, simple design of the sensor and measuring circuit [1].

The most promising methods are those based on anomalous phenomena in the characteristics of the unipolar corona on microelectrodes (microwires, needle and sharp edges). At the initial stage of the negative corona, electrical pulses of various amplitudes and densities appear, which is due to the presence of micro-roughness on the corona-forming surface of the wire. With a developed corona, electron avalanches in the corona layer have the full run length up to the distance $\Delta = 0.3\sqrt{r_0}$, predetermining the appearance of pulses of maximum amplitude and density in the spectrum of the frequency pulses of corona current. It follows that, namely, the amplitude of the pulses with the carrier frequency will be directly dependent on the diameter of the corona wire. Another abnormal effect appears in the developed positive corona when an additional high-frequency voltage with a small amplitude and adjustable frequency is applied to the corona when a resonant oscillating process occurs in the corona discharge cover, and then the corona corona radius is determined by measuring the high-frequency conductivity of the discharge gap [2].

In practically all cases, a differential scheme is used, consisting of two discharge chambers, one of which contains a reference wire and the other a measured wire. In the process of measuring according to this scheme, the effect of temperature, humidity and air pollution on the corona discharge current in both chambers is compensated and the difference in currents depends mainly on the size of the wire itself (diameter and ovality) in the area under study. In addition, in all gas-discharge sensors, guard electrodes are used on both sides, covering the discharge chamber identical in shape with the main chamber, to localize the discharge and reduce current fluctuations. For the same purpose, a positive corona is used (the positive pole of the power supply is connected to the corona wire), which has a more stable and constant operating mode than the negative one.

Tergeussizova Aliya Sovetzhonovna is with Kazakh National University named after al-Farabi, Almaty, Kazakhstan, (e-mail: aliya55@mail.ru).

Bakhtaev Shabden Abuovich is with Almaty University of Power Engineering and Telecommunications, Almaty, Kazakhstan, (e-mail: b.shabden@aes.kz).

Waldemar Wójcik is with Lublin University of Technology, Lublin, Poland, (e-mail: waldemar.wojcik@pollub.pl).

Aitchanov Bekmurza Husainovich is with Suleyman Demirel University, Almaty, Kazakhstan, (e-mail: bekait@rambler.ru).

Mussapirova Gulzada Dauletbekovna is with Almaty University of Power Engineering and Telecommunications, Almaty, Kazakhstan, (e-mail: mgulz1@yandex.kz).

Toigozhinova Aynur Zhumakhanovna is with Kazakh Academy of Transport and Communications named after M.Tynyshtayev, Almaty, Kazakhstan, (e-mail: aynur_t@mail.ru).



III. RESULTS AND DISCUSSION

The conductivity of the corona-discharge gap with a developed corona is one of the important physical parameters for constructing a general theory of corona discharge, as well as to determine the possibility of its technical application. The differential conductivity of the corona discharge, i.e. the dynamic characteristic of the discharge gap is determined by the intensity of ionization processes in the corona layer (corona cover), ion concentration and mobility. At an average ion velocity of about $5 \cdot 10^5$ cm/s, their lifespan in the discharge chambers is in the range from $5 \cdot 10^{-5}$ to $5 \cdot 10^{-6}$ s. [3, 4] Thus, light ions with the greatest mobility during movement do not have time to transform into heavier complex ions or form metastable atoms, the conductivity will mainly depend on the mobilities characteristic of the simplest ions of a given gas.

To study the mobility of ions, a probe technique was used to study the motion of a space charge in a cylindrical capacitor when a mixed voltage was applied to the corona wire, consisting of a constant component and a variable component of the industrial frequency, the amplitude of which does not exceed 5–10% of the constant component. With such a voltage, the corona on the wire exists in the form of periodic flashes (once per period) and at the same time, a space charge of one sign is created in the form of separate layers or waves moving towards the outer cylinder.

To study the initial stages of a high-frequency discharge from a tip in the air at atmospheric pressure, we used the method of measuring the stresses of occurrence and extinction of a discharge from a tip while applying constant and high-frequency voltages in different proportions on the discharge gap [5, 6]. There was a transition of the initial DC voltage streamers to the initial two-voltage streamers, then a transition to discharge similar in shape to a high-frequency one, and, finally, a high-frequency discharge.

Our methodology is different in that, firstly, we examined the developed unipolar corona, where the variable component of the voltage was a probing high-frequency field and was measured separately. Secondly, this high-frequency disturbing field has almost no effect on the integral characteristics of the discharge, and the alternating component of the corona current depends on the conductivity of the corona gap at different frequencies.

Due to the fact that the amplitude of the alternating field is sufficiently small and lies within the linearity of the section of the static current-voltage characteristic of the corona gap, the variable component of the corona current is determined by the differential conductivity of the corona discharge gap in the corresponding section of the static voltage-voltage characteristic. Thus, by setting a certain value of the corona current, it is possible to obtain the frequency dependence of the differential conductivity in different parts of the current-voltage characteristic.

In addition, the method of applying to the gap a constant voltage and simultaneously an alternating voltage with a frequency of up to 1.5 MHz and with an amplitude of up to 100 V was used by us to determine the initial voltage of the appearance of a corona discharge and its dependence on the frequency of the applied alternating voltage at different intervals under various environmental conditions .

The proposed technique was developed and tested on a positive corona since with a negative corona from a microwire there are intermittent signals and statistical current pulses that mask the high-frequency probe voltage and make it difficult to measure the differential conductivity of the discharge gap.

To develop this technique, studies were also made of the static characteristics of the unipolar corona, i.e., the initial field strength, current-voltage characteristics, and their temperature dependences.

Measurement of linear parameters of microwire (MW). A device that implements a new method of controlling the diameter of the wire [7] contains a ring electrode covering a microwire being controlled, a high-voltage power source with adjustable stabilized output current, a load resistor, a separating capacitor for decoupling pulse signals and a pulse voltmeter. When a sufficiently high voltage of positive polarity is applied to the ring electrode, conditions are created for the onset of the pulsed mode of the negative corona, and ionization and excitation of atoms and gas molecules occur in the vicinity of the corona-making microwire, which in turn leads to the formation of numerous electron avalanches. It was established that in the pulsed mode of the negative corona, the amplitude of the pulses is directly dependent on the length of the run-up of electron avalanches in the corona-forming layer, whose thickness is determined by the Peak formula and is equal to $\Delta = 0.3\sqrt{r_0}$, where r_0 is the radius of the microwire. Therefore, by measuring the amplitude of current pulses with a developed corona (10–50 μ A), the radius (r_0) of the corona-making microwire is determined, and it is the amplitudes of such pulses that have the greatest density (carrier frequency) in the corona current pulse frequency spectrum. The output signal is taken from the load resistor and through the separation capacitor is fed to the input of a pulse voltmeter. In the process of measurement, the high-voltage power supply operates in the stabilized current mode with the setting of its value at the source output: 10, 20, and 50 μ A.

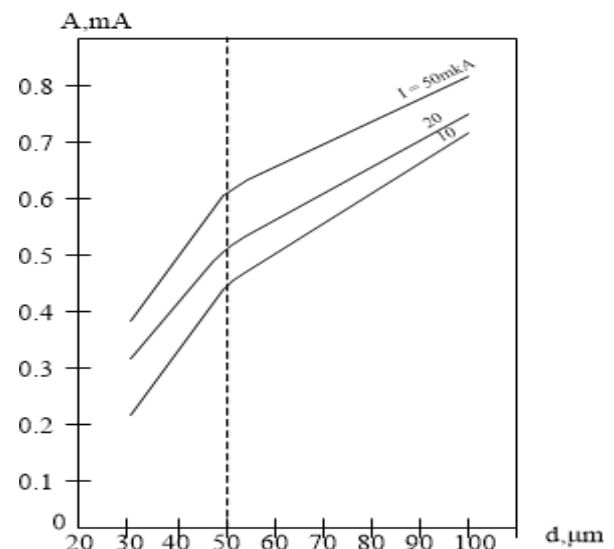

Fig. 1. Current pulse amplitude dependencies on microwire diameter.

Figure 1 shows the dependence of the amplitude of the pulses of the current carrier frequency (A) on the diameter (d) of the corona-producing microwire at different values of the negative corona current. The internal diameter of the outer ring electrode was 1 cm with a working length of 3 cm, the load resistance was 1.2 k Ω , the separation capacity was 1 μ F. The duration of the pulses varied depending on the diameter of the magnetic field and ranged from 30 to 100 μ s.

Experimental measurements have shown that the change in atmospheric air pressure is within ± 20 kPa and vibration of the wire within ± 2.5 mm do not have a significant impact on the accuracy of measuring the diameter of the microwires, which amounted to this method, like all known CT, about 0.5-1% of the measured diameter. The existence of a fracture on the calibration lines and its location are determined by the ratio $\ln D / d$ (D is the diameter of the outer ring electrode), which is included in the formula of the current-voltage characteristic of the corona discharge. Therefore, if necessary, change the measurement range and the shift of the fracture point on the calibration curves in one direction or another, the issue is solved by choosing the value D .

In another device [8], determining the radius of curvature of the corona surface is provided by applying additional high-frequency voltage between the electrodes and adjusting its frequency; it, determine the radius of curvature of the surface of the corona electrode according to the grading curve of equivalent radii, obtained depending on Cheney resonant frequency (f_0).

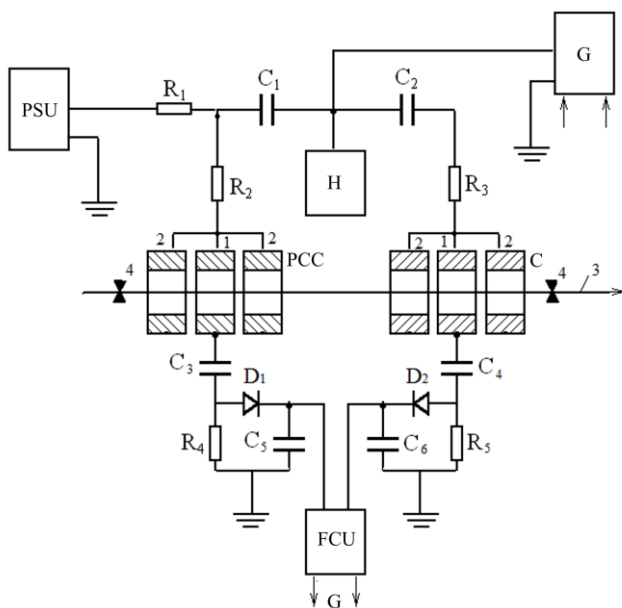

Fig.2. Functional diagram of the device curvature definition

In this case, two cameras are used in the form of cylinders of the same size and in this case, if the high-frequency voltage of small amplitude is supplied to both cameras, then the high voltage is simultaneously applied to only one of the cameras, and the values are measured simultaneously and immediately using a balanced circuit their difference. The frequency control unit under the action of the resulting difference in high-frequency conductance adjusts the frequency of the generator

and automatically finds the resonant frequency when this difference tends to zero.

Figure 2 shows the functional diagram of the device. The device contains two parallel-connected chambers PCC and CC, which consist of measuring I and guard 2 electrodes, measured wire 3, dies or holders 4 microwires, separation capacitors $C - C_4$ ballast R and load resistances $R_2 - R_5$, diodes D, D_2 , power supply unit (PSU), generator (G), frequency meter (H) and frequency control unit (FCU).

A known method for measuring the diameter of microwires, in which a ring electrode is used covering the microwire, between which a voltage of sufficient magnitude is created and the current strength of the corona discharge is measured, the magnitude of which is used to judge the diameter. The disadvantages of this method are the high requirements for the stability of temperature and gas composition in the corona discharge zone.

The closest in technical essence to the method for determining the radius of curvature of the corona surface is a method for controlling the diameter of a microwire, in which by applying a voltage of sufficient magnitude and positive polarity to the outer ring electrode, a negative corona pulse mode is created in the inter-electrode space, and the high-voltage power supply operates in a mode of stabilized current. Then, by measuring with a pulse voltmeter the amplitude of the carrier frequency pulses at the load of the discharge chamber, the diameter of the corona microwire is determined from the calibration curve obtained previously on reference microwire samples [9].

The main disadvantage of the proposed method is that it is not suitable for determining the radius of curvature of the surface of a corona electrode of arbitrary shape (points, needles, sharp edges, etc.). In addition, additional difficulties arise also in the need for high-voltage power supply with a stabilized current and reference samples of microwires.

In our invention, our goal was to develop a method for determining the radius of curvature of the surface of a corona electrode of various shapes, suitable for measurements during testing of high-voltage apparatuses.

The invention relates to measuring technique and can be used in the high voltage technique for determining the radius of curvature of the surface of a corona electrode of arbitrary shape. The technical result of the invention is the high accuracy of determining the radius of curvature of the corona surface (sharp edges) of inaccessible parts of high-voltage equipment.

The advantages of the proposed method is the creation of resonant oscillatory processes in the plasma of the corona discharge sheath by adjusting the frequency of the high-frequency voltage and determining the value of the resonant frequency depending on the radius of curvature of the corona surface, and the resonance frequency is measured while observing the equality of the high-frequency conductivity of the discharge gap in the presence and absence of corona discharge. In contrast to the known methods, including the supply of a high-voltage direct voltage between concentric microwires and an external cylindrical electrode, and the diameter of the microwire is determined by the strength of the discharge current or by the amplitude of the carrier frequency of the pulses, the task in the proposed method is solved by the fact that by feeding

between the electrodes an additional high-frequency voltages with an amplitude lower than the high-voltage constant voltage and frequency regulation create a resonant oscillatory process in the plasma of the corona discharge sheath.

Then, if the values of the high-frequency conductivities of the discharge gap with and without corona are equal, the radius of curvature of the surface of the corona electrode is determined from the calibration curve of equivalent radii obtained depending on the values of the resonance frequencies. A device that implements the proposed method includes a high-frequency voltage generator with an adjustable output frequency, a load resistor, a separation capacitor for removing an alternating current component, a millivoltmeter and an alternating voltage microammeter to determine the high-frequency conductivity of the discharge gap (Figure 3).

One of the possible approaches to the study of corona discharge is to study the features of its characteristics when a constant and small high-frequency (HF) alternating voltage is applied to the discharge gap. The sounding of this gap with the alternating voltage of high frequency with small amplitude allows us to study the dynamic characteristics of the corona gap and, in particular, to determine the dependence of the RF conductivity of the corona discharge on the frequency of the alternating voltage. Using this method, it was possible to establish the frequency ranges of the anomalous conductivity of the corona, which are closely related to the basic physical parameters of the zone of the corona layer (corona cover) [1]

The procedure for determining the dependence of the RF conductivity (q_d) of the corona discharge on the frequency of the alternating voltage was as follows: first, the capacitive current was measured through the corona-discharge gap when an alternating voltage component was applied over the entire frequency range (from 0.2 to 1.5 MHz). Then, a high potential was applied to the corona-discharge gap, and at a certain, predetermined value of the direct current of the corona discharge, the total signal — the variable component of the current in the same frequency range — was measured. The corresponding capacitive component of the current was subtracted from the total, and the HF conductivity curves of the corona were plotted based on this difference, depending on the frequency of the alternating voltage. The RF conductivity of the discharge gap was determined by the ratio of the value of the alternating component of the corona current to the value of the applied alternating voltage.

When constructing the frequency dependence of the RF conductivity of the corona from the arithmetic difference between the total current and the bias current (capacitive component), it was found that the q_d values can be more or less, or equal to the RF conductivity of the discharge gap in the absence of a corona constant current (q_e).

Of greatest interest to us is the frequency range when $q_d = q_e$, which is primarily associated with the electronic component of the current in the case of the corona discharge. In this case, the plasma resonance appears in the corona cover, i.e. the resistance of the crown cover zone to alternating voltage becomes minimal (voltage resonance), and the q_d value compares with q_e . It was found that the frequency f_0 , at which $q_d - q_e = 0$, is very sensitive to changes in the radius of curvature of the corona surface and

the current of the corona discharge. This means that f_0 , first of all, will depend on the electron drift velocity, their density and the change in the mean free path of electrons in the corona layer of the discharge gap. In addition, f_0 will also depend on the thickness of the corona layer (crown cover), which, in turn, is determined by the radius of curvature of the corona surface. Therefore, in the case of constant corona discharge current to determine the radius of curvature of the corona surface, we measured f_0 at $q_d = q_e$.

The solution to the problem for a corona surface of arbitrary shape is extremely complex and therefore, approximate and semi-empirical methods are developed for determining the initial field strengths for electrodes of various geometries [1].

As is known, a corona discharge occurs at the top of the surface and, with a further increase in voltage, propagates along the rest of the surface. To determine the initial corona discharge intensity, in the case of arbitrarily shaped electrodes, the connection between the change in the electrostatic field strength in the immediate vicinity of the electrode surface and the radii of curvature of this surface is usually used:

$$-\frac{dE}{E} = \left(\frac{1}{R_1} + \frac{1}{R_2} \right) dx$$

In the simplest way, it is calculated when the electrode is a surface of revolution, for example, if the needle is approximated by a hyperboloid of revolution. In this case, the maximum radius of curvature (R_2) is equal to the radius of curvature of the curve by rotation of which the electrode is obtained, and the minimum (R_1) is equal to the normal to this curve from the axis of rotation to the point in question.

The radius of curvature of the top of the electrodes is precisely determined at the initial stage of the corona discharge. Indeed, for the vertex of an arbitrary-shaped electrode, we can assume that $R_1 \ll R_2$, then with a certain error by the formula (5.15) we obtain frequency according to the calibration curve find that, ultimately, determines the radius of curvature of the corona surface of the electrode of arbitrary shape.

The value of f_0 ($q_d = q_e$) for a given configuration of electrodes and with a constant corona discharge characteristics (constant discharge current and atmospheric conditions) is found as follows: first, the dependences of the RF conductivity of the discharge gap (q_e is capacitive) on the frequency of the alternating voltage in the absence of corona discharge. Then, the dependences of the RF conductivity in the presence of corona discharge (q_d) are constructed and, by coincidence, $q_d = q_e$, they find the value f_0 , which is used to determine from the calibration curve, which corresponds to the radius of curvature of the surface of an electrode of arbitrary shape.

When determining the radius of curvature of the surface of an arbitrary-shaped electrode, constant high and alternating high-frequency voltages are applied to the second electrode in the form of a flat disk ($D \sim 2$ cm), closely located (4 - 5 mm) to the corona electrode (Figure 3.1). An alternating sinusoidal voltage with an adjustable frequency from 200 Hz to 1.6 MHz is supplied from the generator of the GS-100I type to the discharge gap, and the high-voltage voltage is supplied from a high-voltage source of the VS-23 type. The parameters of the output AC voltage are measured at a load of 1 k Ω using an oscilloscope DESO-2, a voltmeter V3-2A and a frequency meter Ch3-22.

The direct current of the corona is pre-set using an A-1244 class 0.2 microammeter, which is then turned off in order to eliminate the influence of stray capacitances and pickups on the accuracy of the main signal measurement. The amplitude of the alternating high-frequency voltage was selected in the range from 2 V to 100 V, depending on the steepness of the characteristics of the positive corona and the geometric dimensions of the discharge gap.

To construct a calibration curve (Fig. 3), the dependence of the equivalent microwire radius on f_0 was used for discharge chambers in the form of a cylinder with a diameter of 2 to 36 mm, and the central corona electrode was tungsten microwires with a diameter of 5 μm to 50 μm .

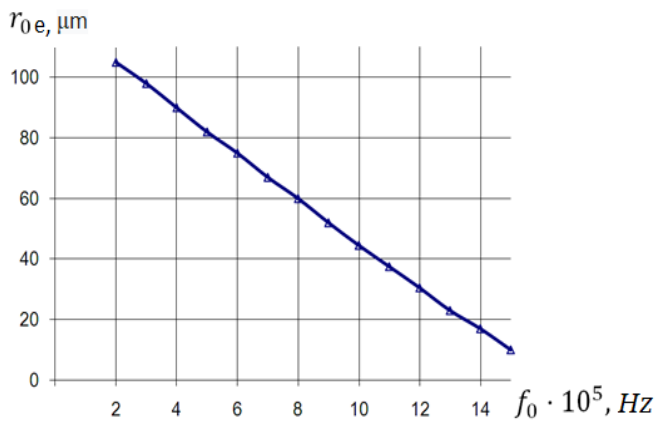

Fig. 3. Dependences of the equivalent radius on f_0

The experimental values of f_0 were determined for a corona discharge in a cylindrical electrode system, when $R = 0.2 \text{ cm}$, $U_0 = 10 \text{ V}$, $I = 20 \mu\text{A}$. It should be noted that when determining the radius of curvature of the surface of the stationary parts of high-frequency equipment, load resistance of 1 k Ω was located in the high-voltage circuit.

A method for determining the radius of curvature of the surface of a corona electrode, comprising supplying a high voltage DC voltage between concentrically arranged microwires and an external cylindrical electrode, when the diameter of the microwire is determined by the strength of the discharge current or the amplitude of the carrier frequency of the pulses, characterized in that by supplying an additional high voltage with an amplitude between the electrodes, lower than the high-voltage constant voltage and adjusting its frequency, create a resonant oscillatory process in the plasma of the corona discharge sheath. Then, if the values of the high-frequency conductivities of the discharge gap with and without a corona discharge are equal, the radius of curvature of the surface of the corona electrode is determined from the calibration curve of equivalent radii obtained depending on the values of the resonance frequencies.

Figure 4 shows the device for measuring the speed of pulling the microwire during its manufacture. In this case, a high-voltage power supply 4 with negative polarity at the output is used, which creates a positive space charge in the discharge gaps between the electrodes 1 and 3 with wire 2. In addition, the device contains an output device 5 connected to the signal points of the balanced circuit (a, b) which is formed by two discharge

gaps 3 and their load resistances 6, and to establish the equality of the shoulders of the balanced circuit, variable resistance 7 is used. To stabilize the corona discharge current on the main the ballast resistance is used in the outgoing electrode 8. When a sufficiently high voltage of negative polarity is applied to the ring electrodes 1 and 3, conditions are created for the occurrence of a corona discharge between the ring electrodes and the wire, and a corona layer (corona shell) with a positive space charge is formed near the corona-carrying microwire. After that, with the help of resistance 7, the zero reading of the output device is established when the wire is stationary. When the wire broach is turned on, the value of the voltage potential difference across loads of 6 two discharge gaps 3 is measured, which in essence will correspond to the wire pulling speed. The device is characterized by simplicity and convenience of operation, provides inertiality and continuity of measurements. In addition, the calibration of the output device is required to be carried out only once.

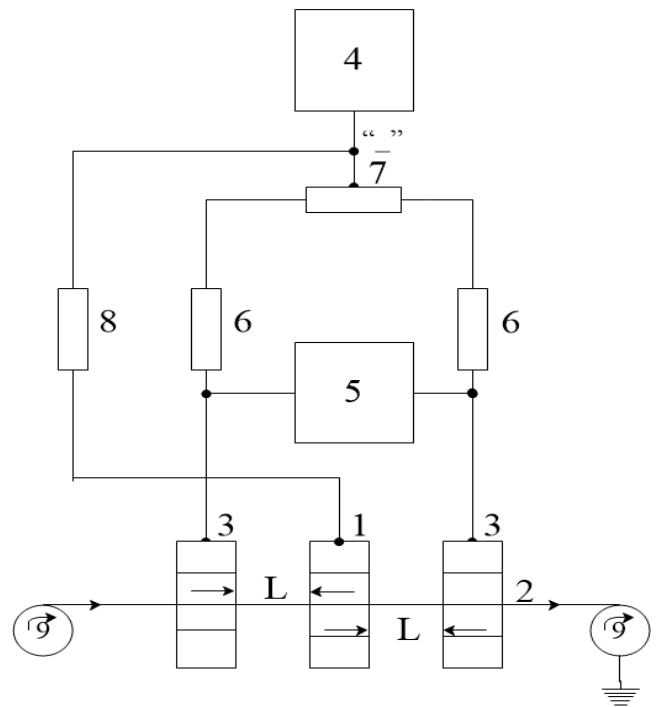

Fig.4. Functional diagram of a device for measuring the speed of a microwire drawing during its manufacture

Figure 5 shows the dependence of the potential voltage difference (U, mV) at the signal points of the balanced circuit from the speed of the wire flow ($V, \text{m/min}$). The device has the following parameters: the inner diameter of the ring electrodes is 10 cm with a working length of 1 cm, the diameter of the controlled microwire is 100 microns. The corona discharge current is 40 μA in each discharge gap at a supply voltage of 5 kV. The distances between the electrodes 3–1 and 1–3 were set to about $l = 0.1\text{cm}$. A balanced electronic voltmeter with a sensitivity of 0.1mV was used as the output device, and the load resistances 6 were equal to 100k Ω .

Experimental measurements of the speed of the microwire broach were performed on the rewinding unit 9 with the limit of change of the rewind speed to 30m/min. Experimental tests have

shown that a change in atmospheric air pressure of ± 20 kPa and a variation in wire diameter of ± 10 microns does not significantly affect the accuracy of measuring the speed of the microwire drawing, which was about 1–2% of the measured speed by this method.

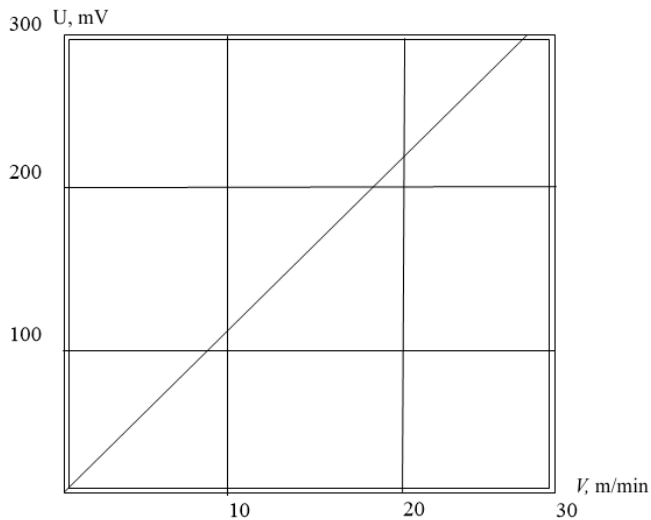

Fig.5. Dependence of the voltage potential difference at the signal points of the balanced circuit from speed wire broach

Significant heterogeneity of the electric field causes a sharply different nature of the flow of the corona discharge current in the inner and outer corona regions. Moreover, the internal corona layer is the key that determines all the characteristic features of the discharge as a whole. Ionization processes in the corona discharge occur in the corona layer near the electrode with a small radius of curvature. The presence of the measuring probe in this area significantly violates the distribution of field strength and space charges. Therefore, the discharge parameters of the corona layer are usually judged by the data of external electrical characteristics, the initial field strength, or by the structure of the corona glow [1]

One of the possible approaches to the study of corona discharge is the study of the features of its characteristics when applying to the discharge gap at the same time a high-voltage direct and small-sized high-frequency alternating voltage [10].

Sounding with a high-frequency alternating voltage with a small amplitude allows one to study the dynamic characteristics of the corona gap and, in particular, to determine the dependence of the RF conductivity of the corona discharge on the frequency, during the study of which anomalous effects were discovered [11].

The study of the corona zone presents certain difficulties from both the experimental and theoretical sides, which requires the development of special methods and equipment. The most promising method is the determination of the RF conductivity of the corona at various frequencies of the alternating current component, which makes it possible to a certain extent to eliminate the influence of the external region of the discharge. In particular, using this method it was possible to establish frequency regions of the anomalous conductivity of the corona, which are closely related to the main physical parameters of the zone of the corona layer.

IV. CONCLUSIONS

The method described in this article is the way to solve the problem of non-contact and continuous measurement of the drawing speed of thin and ultra-thin (10 to 100 microns) under manufacturing conditions, which is necessary when setting up and selecting a microwire manufacturing technology on multiple drawing machines.

REFERENCES

- [1] Sh.A.Bahtaev, A.A.Bokanova, G.V.Bochkareva, G.K.Sydykova. Fizika i tehnika koronnorazrjadnyh priborov. Almaty 2007.
- [2] Sh.A.Bahtaev, G.K.Sydykova, A.Zh. Tojgozhinova, K.Kodzhabergenova. Koronnyj razrjad na mikrojelektrodah. Almaty 2017 – 78p.
- [3] Sh.A.Bakhtaev, G.V.Bochkareva., G.D.Musapirova, “The pulsed current mode of the negative corona,” *Vestnik Kaz NTU*, no. 3, pp. 212-217, 2010.
- [4] T. Abiru, F. Mitsugi, T. Ikegami, K. Ebihara, S. -ichi Aouki, K. Nagahama, “Environmental application of electrical discharge for ozone treatment of soil,” *Informatyka, Automatyka, Pomiar w Gospodarce i Ochronie Środowiska*, vol. 5, no. 4, pp. 42-44, 2015, <https://doi.org/10.5604/20830157.1176573>.
- [5] Z. Lv, S. Rowland, S.Chen, H. Zheng, K.Wu, “Modelling of partial discharge characteristics in electrical tree channels: Estimating the PD inception and extinction voltages,” *IEEE Transactions on Dielectrics and Electrical Insulation*, no. 25, pp. 1999-2010, 2018. doi: 10.1109/TDEL.2018.007175.
- [6] M. Szadkowski, “New method of analysis of partial discharges,” *Przegląd Elektrotechniczny*, vol. 90 no. 3, 103-106, 2014. doi: 10.12915/pe.2014.03.21
- [7] Sh.A. Bahtaev, G.V.Bochkarjova, G.I. Bokova, “Sposob kontrolja diametra mikroprovoloiki,” Republic of Kazakhstan Patent no. 5070, *Ofic.bjull., Prom.sobstv.*, no. 10, 1998.
- [8] Sh.A.Bahtaev, G.D. Musapirova et al., “Ustrojstvo dlja izmerenija diametra mikroprovoloiki,” Republic of Kazakhstan Patent no. 96543, *Ofic.bjull., Prom.sobstv.*, no. 2, 30.01.2017.
- [9] Predpatent RK №12038.Sposob izmerenija skorosti protjazhki mikroprovoloiki // Bahtaev Sh.A. i dr.Opubl. Bjull.№9, 16.09.2002.
- [10] G.V.Bochkareva, G.D.Musapirova, “The frequency characteristics of the differential conductivity of the corona in the high-frequency region,” in *proc. The main problems of modern science: international materials. scientific-practical conf. - Bulgaria*, pp. 92-94, 2010.
- [11] Sh.A.Bakhtaev, G.V.Bochkareva, G.D. Musapirova, “Areas of existence of anomalies in the high-frequency conductivity of the positive corona,” *Tomsk State University Journal. AIPP* no. 2, pp. 18-23, 2010.