

# Estimation and Compensation of IQ Imbalance in SWIPT System

Ajin R. Nair, S. Kirthiga, M. Jayakumar

**Abstract**—Although there are many articulations of SWIPT architecture implementations, the hardware impairment aspect involved in the SWIPT architecture system is not given much attention. This paper evaluates the performance of SWIPT PS Receiver architecture in the presence of IQ imbalance hardware impairment with 16-QAM transmitter and AWGN channel. The parameters SNR, BER is evaluated in the presence of amplitude, phase imbalance, and PS factor at the SWIPT receiver side. Further, the IQ imbalance is estimated and compensated using a blind compensation algorithm. The system achieved a maximum BER of  $10^{-7}$  in the presence of amplitude and phase imbalance of 0.2 and 1.6 respectively.

**Keywords**—SWIPT, Power Splitting, IQ imbalance, Energy harvesting, Hardware impairments, Blind Compensation

## I. INTRODUCTION

As we know, any typical wireless communication system will possess a Transmitter, Channel, and Receiver section. The components used in transceivers are not ideal and suffer numerous hardware impairments. The transceiver of RF (Radio Frequency) wireless nodes suffer impairments such as IQ (In-phase and Quadrature) imbalance, nonlinearity in amplifier, and phase noise [1], [2] in a real environment. To compensate for the impairments and to improve the performance, it is inevitable to have hardware impairment modeling in any RF system.

The direct digitization of the RF will be costly and difficult in multi gigahertz bandwidth (60 GHz) systems such as IEEE 802.11ad which are limited to use analog to digital converter or digital to analog converter [3]–[7]. In these cases, analog IQ modulators and demodulators provide simple, compact, and low-cost solutions [8]. However, imperfections due to amplitude and phase imbalances deteriorate the performance of Quadrature modulated systems which is commonly called IQ imbalance. Therefore to enhance the performance of Quadrature modulated systems, it is necessary to model IQ imbalance parameters.

The energy harvesting of RF signals combined with wireless communication systems opens up a new opportunity for SWIPT (Simultaneous Wireless Information and Power Transfer). It gains its importance in systems with energy constraints like the remote sensors and User Equipment (UE). The signal which carries energy and information cannot be processed simultaneously. So there are two possible implementations

of SWIPT that is Time Switching (TS) and Power Splitting (PS) architectures. The TS architecture splits the signal in the time domain whereas PS architecture does it in the power domain. The PS architecture is having an advantage over TS as it does not waste the time resource for transmission. Also, the information rate of PS is higher than the TS architecture [9]. The results on the comparison of information rate in PS and TS architecture with the help of rate-energy function is done in [10].

In PS architecture, the PS factor decides how much of the received power should be given for energy harvesting [11]. The PS factor is determined by statistic channel state information (CSI) and hence it is important to develop dynamic PS strategies [12]. The maximum harvestable power with optimized receiver architecture under the constrain of Channel State Information (CSI) was discussed in [13]. The PS factor also influences outage probability as it decides the amount of received signal for information decoding [14].

The SWIPT implementations in the literature mostly consider ideal receivers. The SWIPT design with an ideal receiver capable of simultaneously monitoring and extracting power from the signal is introduced [1]. But there is a rare probability for such an ideal receiver can exist in the practical implementation of SWIPT [15], [16]. Therefore we see the interesting fact that most of the research involving SWIPT architectures has not given much attention to hardware impairment modeling.

In this paper, we enhance the performance of IQ Imbalance in a SWIPT PS Receiver Architecture system using a decision-directed based mitigation approach. The IQ imbalance estimations with decision-directed approaches require less amount of data compared with the data-aided approach that requires a huge amount of pilot data [17]. The simulation result clearly shows that a decision-directed based mitigation approach can enhance the performance of SWIPT receivers that employs IQ modulation schemes. The paper is arranged in various sections as follows. In section 2, a model for direct conversion transmitter and SWIPT PS receiver is described. Section 3 describes the results and discussion tailed by concluding observations in Section 4.

## II. SYSTEM MODEL

### A. Transmitter Model

The model consists of direct conversion transmitter and receiver architectures employing IQ modulation schemes. The transmitter architecture with IQ modulation shown in Fig. 1.

Authors are with Department of Electronics and Communication Engineering, Amrita School of Engineering, Coimbatore, Amrita Vishwa Vidyapeetham, India (e-mail: rn\_ajin@cb.students.amrita.edu, s\_kirthiga@cb.amrita.edu, m\_jayakumar@cb.amrita.edu).



upconverts the baseband signal  $T(t)$  using the quadrature mixing structure. The digital baseband signal consisting of the real  $R(\cdot)$  and imaginary part  $I(\cdot)$  is passed through digital to analog converter (D/A). The signals to be transmitted in the In-phase and quadrature branches are  $T_I(t)$  and  $T_Q(t)$  respectively. The local oscillator signal which multiplies the in-phase is having  $90^\circ$  phase shift with respect to the quadrature signal. The RF signal,  $T_{RF}(n)$  which is converted using IQ modulation is fed across the Power Amplifier (PA) before transmission. Note that at the transmitter side we do not have any IQ imbalance and we assume perfect matching of IQ branches with PA having a perfect unity gain.

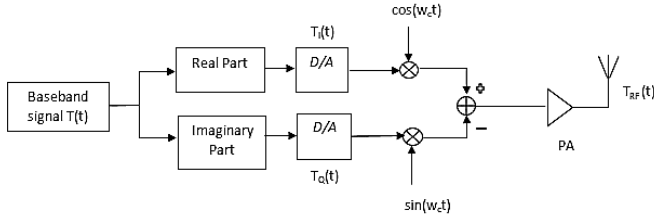

Fig. 1. Transmitter architecture with IQ modulation scheme

The discrete time model of the transmitter architecture for easy analysis is shown in Fig. 2

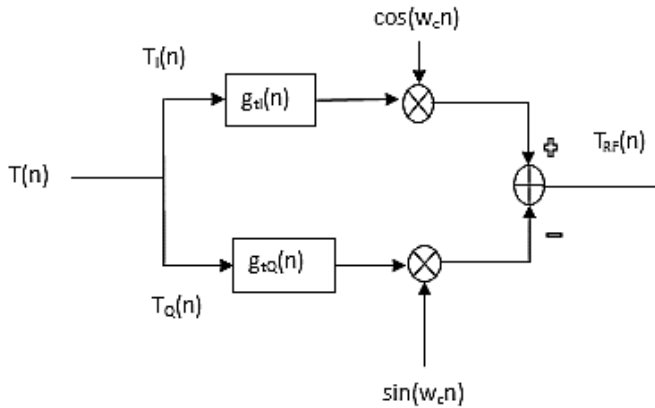

Fig. 2. Discrete time transmitter model with IQ modulation scheme

In the discrete time transmitter model,  $T_I(n)$  and  $T_Q(n)$  represents the signals in discrete form which is to be passed through the IQ branches respectively. The IQ branches at receiver side are considered to have filter impulse responses  $g_{tI}(n)$  and  $g_{tQ}(n)$  respectively. The signal to be transmitted can be written as

$$T(n) = T_I(n) + jT_Q(n) \quad (1)$$

The transmitted signal  $T_{RF}(n)$  after IQ modulation can be represented as

$$T_{RF}(n) = [(T_I(n) \otimes g_{tI}(n)) \cos(w_c n) - (T_Q(n) \otimes g_{tQ}(n)) \sin(w_c n)] \quad (2)$$

Where  $w_c$  is carrier frequency and  $\otimes$  represents convolution.

## B. Receiver Model

In the receiver architecture shown in Fig. 3, a PS scheme is adopted where the signal is splitted with  $\rho$  as the PS factor having  $\sqrt{\rho}$  power delivered to the energy harvester module and  $\sqrt{1-\rho}$  power delivered to the information receiver module. The factor  $\rho$  decides the amount of power to be delivered to the energy harvesting module and information receiver module. The energy harvester module will storage the energy with the help of rectenna units and the received signal is decoded with the help of information receiver module. The PS architecture opens up the possibility of SWIPT in which information and power exchange happens simultaneously. The receiver side is modelled with IQ imbalance having an amplitude mismatch  $\epsilon$  and phase mismatch  $\theta$ .

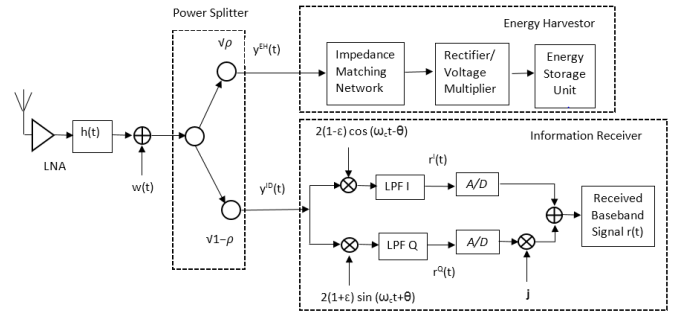

Fig. 3. PS receiver architecture with IQ imbalance modelled

The received signals at the energy harvester module  $y^{EH}(n)$  can be expressed as

$$y^{EH}(n) = \sqrt{\rho} P_T y^{RF}(t), 0 \leq t \leq L \quad (3)$$

Where  $L$  is the total transmission time with  $P_T$  as the transmitted power. The total energy harvested from the energy signal equals

$$E = \eta \rho P_T |h^2| L \quad (4)$$

Where  $\eta$  represents energy conversion efficiency and  $h$  represents the channel gain between the transmitter and the receiver. The rate-energy function for PS is defined in [10] as

$$C(R, Q) = \left\{ Q \leq \eta \rho P_T |h^2|, R \leq \log_2 \left[ 1 + \frac{(1-\rho) P_T |h^2|}{(1-\rho) 2\sigma_a^2 + 2\sigma_d^2} \right] \right\} \quad (5)$$

Where  $R$  is the information rate,  $Q$  is the harvested energy,  $2\sigma_a^2$  and  $2\sigma_d^2$  denotes the Additive White Gaussian Noise (AWGN) generated by antenna and energy conversion respectively.

Also the received at the information receiver can be written as

$$y^{ID}(t) = \sqrt{(1-\rho)} P_T y^{RF}(t), 0 \leq t \leq L \quad (6)$$

The simplified discrete time model of the information receiver with IQ imbalance is shown in Fig. 4

The IQ branches at the receiver side are considered to have filter impulse response  $g_{rI}(n)$  and  $g_{rQ}(n)$  respectively. The

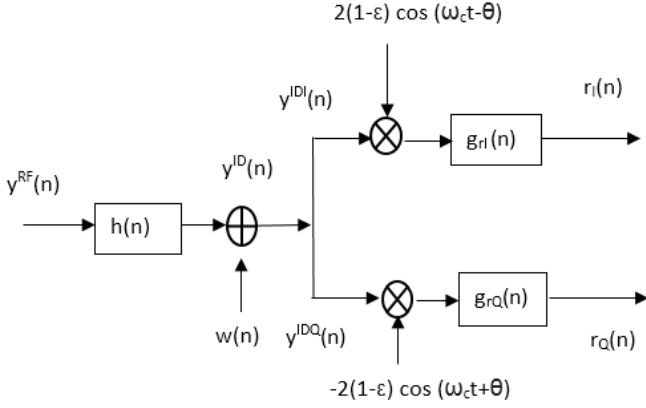

Fig. 4. Simplified Receiver model with IQ modulation scheme

received radio frequency signal  $y^{ID}(n)$  at the information receiver side can be expressed as

$$y^{ID}(n) = \left[ y^{RF} \otimes h(n) \right] + w(n) \quad (7)$$

Where  $w(n)$  is the AWGN experienced in the channel with variance  $2\sigma^2$

The information signal for IQ demodulation can be expressed as

$$y^{ID}(n) = y^{IDI}(n) + jy^{IDQ}(n) \quad (8)$$

The demodulated output with IQ imbalance is equal to

$$r^I(n) = LPF \left\{ \left[ 2y^{ID}(n)(1 - \epsilon) \cos(w_c t - \theta) \right] \otimes g_{rI}(n) \right\} \quad (9)$$

$$r^Q(n) = LPF \left\{ \left[ -2y^{ID}(n)(1 + \epsilon) \cos(w_c t - \theta) \right] \otimes g_{rQ}(n) \right\} \quad (10)$$

The Low Pass Filter (LPF) option removes the image frequencies. From (6), the demodulated output with IQ imbalance and PS factor is equal to

$$r^I(n) = LPF \left\{ \left[ 2\sqrt{(1 - \rho)} P_T y^{RF}(n)(1 - \epsilon) \cos(w_c t - \theta) \right] \otimes g_{rI}(n) \right\} \quad (11)$$

$$r^Q(n) = LPF \left\{ \left[ -2\sqrt{(1 - \rho)} P_T y^{RF}(n)(1 + \epsilon) \cos(w_c t - \theta) \right] \otimes g_{rQ}(n) \right\} \quad (12)$$

The baseband signal received with IQ imbalance can be expressed as

$$r(n) = r^I(n) + jr^Q(n) \quad (13)$$

As mentioned in [18], we can express the SNR (Signal to Noise Ratio) in receiver only IQ imbalance PS architecture as

$$SNR = \left| \frac{\sqrt{(1 - \rho)}}{\xi} \right|^2 \quad (14)$$

where  $\xi$  is the receiver IQ imbalance parameter defined as  $\xi = \frac{-\beta}{\alpha}$  and  $\alpha = \cos \theta - j\epsilon \sin \theta$  and  $\beta = \epsilon \cos \theta + j \sin \theta$

As suggested in [19] a circularity based blind compensation algorithm is applied to retrieve the transmitted signal. The compensator structure is shown in the Fig. 5

$$y(n) = x(n) + w_T(n)x^*(n) \quad (15)$$

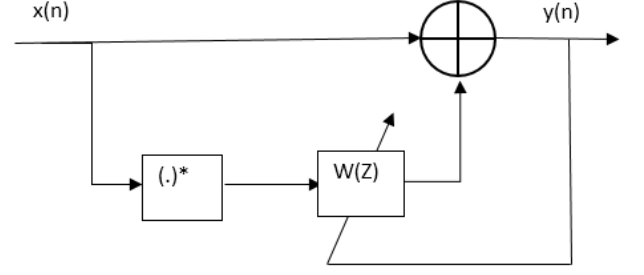

Fig. 5. IQ Imbalance compensator structure

$$w_T(n+1) = w(n) - My^2(n) \quad (16)$$

Where  $x(n)$  is the input,  $y(n)$  is the output,  $w_T(n)$  is the weight matrix and  $M$  is the step size.

The algorithm employs an adaptive filter in order to retrieve the transmitted data. The weights of the filter are adjusted in such a way that the RX IQ imbalance is compensated to retrieve the transmitted data. The simulation results show that the performance of blind compensation algorithm is found to be good in estimating and compensating for the IQ imbalance in SWIPT system, which we shall discuss in the next section.

### III. RESULTS AND DISCUSSION

#### A. Simulation Results

TABLE I  
SIMULATION PARAMETERS WITH VALUES

Parameters	Values
Modulation	16 QAM
Number of data taken	1000000
Sampletime	10 ns
Samples per frame	1250
Eb/No	-5 dB to 25 dB

1) *Rate Energy Function for PS*: Initially, the rate energy function for PS is plotted considering  $\eta = 1$ ,  $P_T = 100$ ,  $h = 1$  and  $2\sigma_d^2 = 1$ . The rate energy region resides below the convex function boundary as shown in Fig. 6. We can see that as the noise power reduces or when the SNR value is increased, the rate-energy region increases. When the PS factor  $\rho$  is increased, more power can be harvested but the information rate decreases. Therefore, there is always a trade-off in energy and information in a SWIPT based communication system.

2) *SNR Evaluation*: The next simulation results show the influence of IQ imbalance parameters on the received signal quality in the SWIPT PS architecture. The SNR is plotted considering amplitude mismatch, phase mismatch and PS factor. Initially, the SWIPT PS system with  $\rho=0.2$  is considered, which focuses more on information decoding than energy harvesting.

The Fig. 7 shows the changes in SNR with IQ imbalance  $\epsilon$  and  $\theta$  with  $\rho=0.2$ .

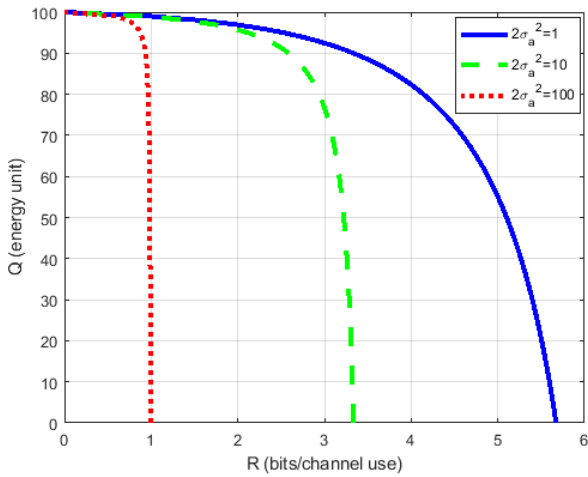

Fig. 6. Rate Energy Function for PS

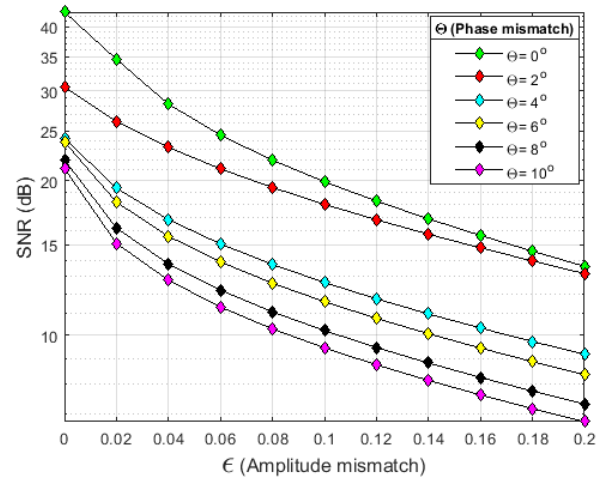

Fig. 8. IQ Imbalance effect on SNR with  $\rho = 0.4$

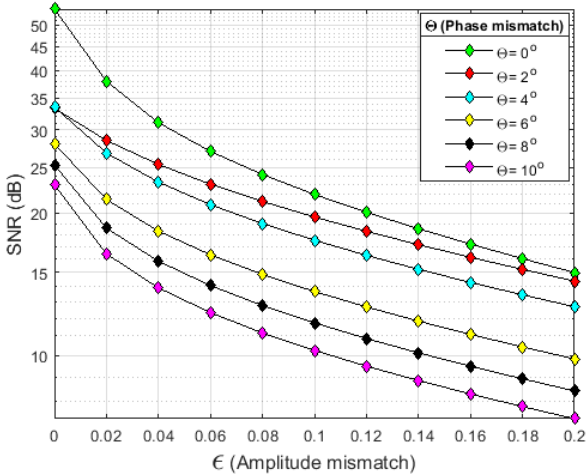

Fig. 7. IQ Imbalance effect on SNR with  $\rho = 0.2$

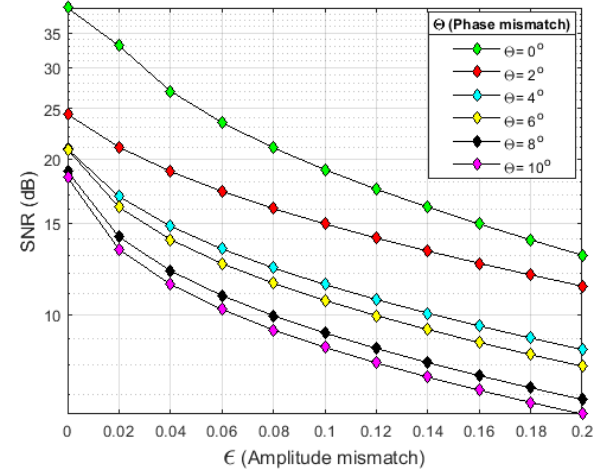

Fig. 9. IQ Imbalance effect on SNR with  $\rho = 0.6$

The SNR yielded is maximum when there are no mismatches in amplitude and phase. Initially, if we look at the plot when phase mismatch is  $2^\circ$ , it is also observed that the amplitude mismatch alone can cause significant degradation in SNR performance. We can observe that to obtain at least 25 dB SNR, the maximum allowed amplitude mismatch is about 0.04 and phase mismatch is about  $2^\circ$ . If we look at the plot when  $\rho = 0.4$  as shown in Fig. 8, we can see that to obtain at least 25 dB SNR, the maximum allowed amplitude mismatch is about 0.02 and phase mismatch is about  $2^\circ$  which is a stringent requirement. The subsequent plots which vary  $\theta$  values more than  $4^\circ$  shows that there is a drastic fall in SNR even when there are minor changes in amplitude imbalances.

Next, we consider the SWIPT PS system with  $\rho = 0.6$  as shown in Fig. 9 which focuses more on energy harvesting than information decoding. Here, to obtain an SNR margin of 25 dB, the maximum allowed amplitude mismatch is 0 and phase mismatch is  $2^\circ$  which is a tough requirement.

The SWIPT system with  $\rho = 0.8$  as shown in Fig. 10 is not recommended for information decoding as it only assures a 25 dB SNR margin when the amplitude imbalance 0.2 and phase imbalance is  $0^\circ$ . The above results call for the estimation and compensation of IQ Imbalance in SWIPT systems.

*3) BER Performance with Estimation and Compensation:* The BER (Bit Error Rate) is a very important parameter which shows the performance of any wireless communication system. As discussed in the previous section, it is necessary to estimate and compensate the IQ imbalances occurring in a SWIPT system. Here we simulate the SWIPT PS system by applying the blind compensation algorithm to mitigate the effects of IQ imbalance in the receiver side. The blind compensation algorithm used here is a non-data aided based adaptive algorithm. The performance of the algorithm is evaluated for all the  $\rho$  values that we considered before. The local oscillator at the receiver side is assumed to have an amplitude and

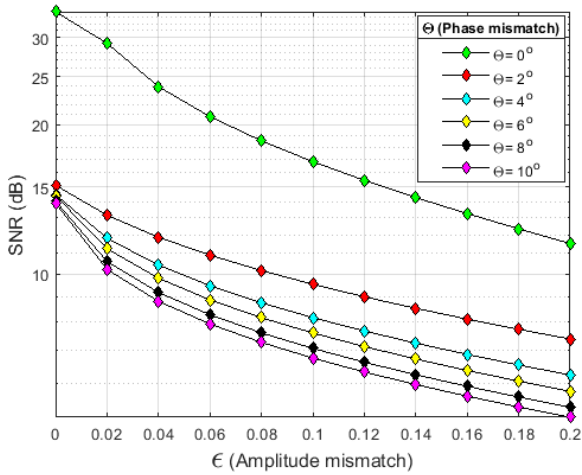

Fig. 10. IQ Imbalance effect on SNR with  $\rho = 0.8$

phase imbalances of  $\epsilon = 0.2$  and  $\theta = 1.6$  respectively. The simulation results of IQ imbalance before and after estimation and compensation is evaluated with ideal case (without IQ imbalance) as a reference.

As done before, initially we focus more on information decoding than energy harvesting by choosing  $\rho = 0.2$  as shown in Fig. 11. The ideal case, that is with no IQ imbalance which gives a BER rate  $10^{-8}$  at the maximum SNR value of 25 dB. The compensation algorithm gives a good BER value of  $10^{-7}$  at the maximum SNR value of 25 dB which is found to be effective when we compare the same with IQ imbalance having a BER value of  $10^{-4}$ .

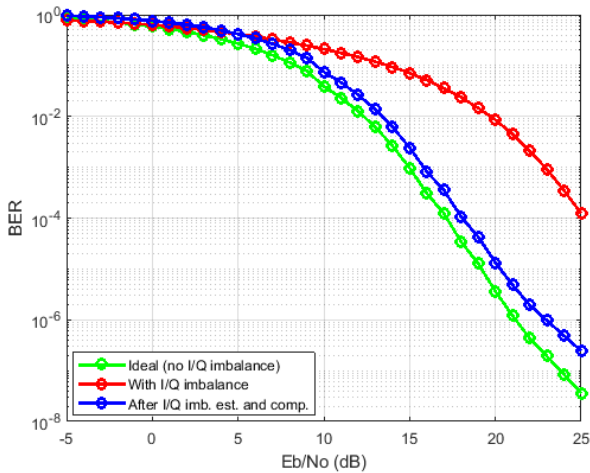

Fig. 11. BER performance with  $\rho = 0.2$

When  $\rho = 0.4$  as shown in Fig. 12, the BER performance of compensation algorithm is in between  $10^{-6}$  and  $10^{-7}$  which is very close to that of the ideal case. Here also compensation algorithm is found to be effective when compare the same with IQ imbalance having a BER value about  $10^{-4}$ .

Next, consider  $\rho = 0.6$  and  $\rho = 0.8$  shown in Fig. 13 and Fig. 14 which focuses more on energy harvesting than

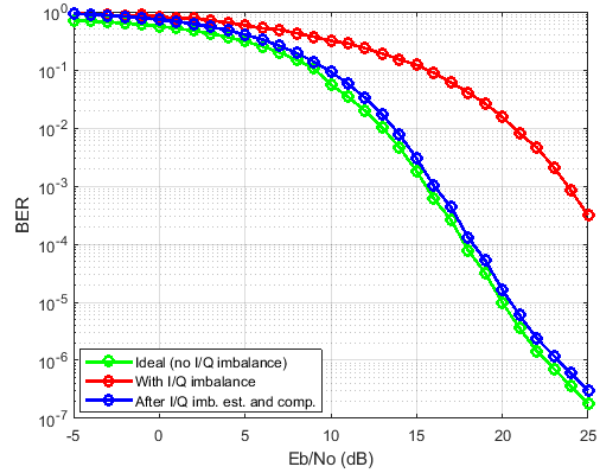

Fig. 12. BER performance with  $\rho = 0.4$

information decoding. Here the BER performance with IQ imbalance is poor and is in between  $10^{-1}$  and  $10^{-2}$ . The compensation algorithm compensates IQ imbalance to a range in between  $10^{-3}$  and  $10^{-4}$ .

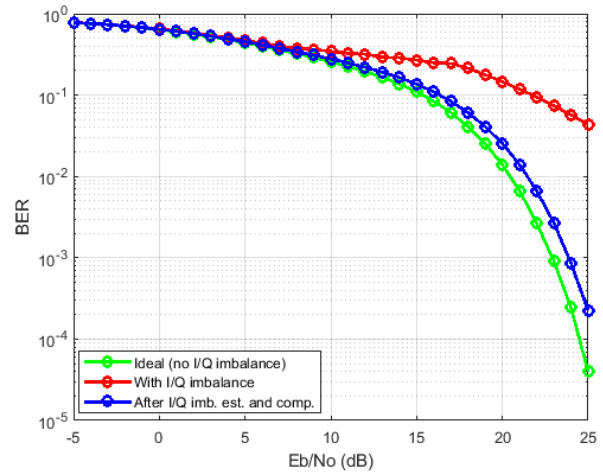

Fig. 13. BER performance with  $\rho = 0.6$

From the above results, it is evident that blind compensation can be used to effectively compensate the RX IQ imbalance in SWIPT system. The  $\rho$  value must be chosen carefully considering the IQ imbalance mismatches. There is a large degradation in BER in the presence of IQ imbalances for  $\rho$  values greater than 0.6 which focuses more on energy harvesting than information decoding.

#### IV. CONCLUSION

In this paper, we have done the estimation and compensation of IQ imbalance in a PS based SWIPT system using blind compensation algorithm. We have started the work considering an IQ modulated transmitter and a SWIPT PS receiver. The SWIPT PS receiver side is then modelled with IQ imbalance

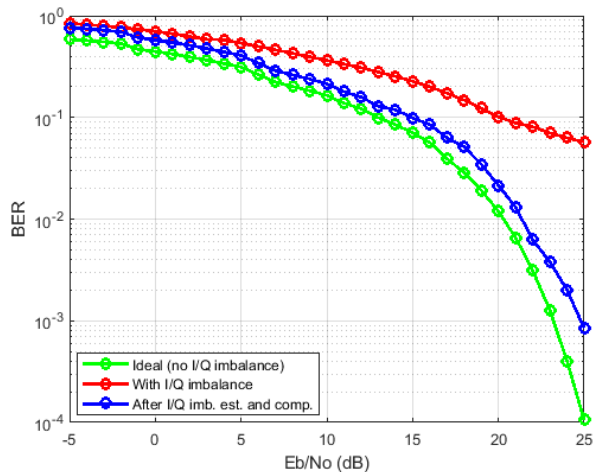

Fig. 14. BER performance with  $\rho = 0.8$

TABLE II  
BER/SNR COMPARISON OF SWIPT MODELS

Reference	System Model	Maximum attained BER
[20]	Decode and forward SWIPT TS/PS assisted relay networks	$10^{-4}$ for SNR value of 20dB
[21]	Millimeter wave based SWIPT PS	$10^{-6}$ for SNR value of 37dB
[22]	Decode and forward SWIPT PS with beamforming and CSI mismatch	$10^{-4}$ for SNR value of 25 dB
[23]	SWIPT PS with Receive Spatial Modulation	$10^{-4}$ for SNR value of 14 dB
This Paper	IQ Imbalance compensated SWIPT PS receiver	$10^{-7}$ for SNR value of 25 dB

parameters like amplitude mismatch and phase mismatch. Later, IQ imbalance estimation and compensation is performed on a SWIPT PS architecture using blind compensation algorithm. The simulation results show that blind compensation algorithm can solve IQ imbalance problems in to a good extend. The IQ imbalance deteriorates SNR of a SWIPT PS architecture when we focus more on energy harvesting rather than information decoding. As this work is limited to receiver only IQ imbalance it is encouraged to evaluate both the transmitter and receiver IQ imbalance impairments modelled for a SWIPT PS architecture. From the results obtained from this work itself, we can predict that the combined IQ imbalance impairments of transmitter and receiver will have more deteriorating effects on the quality of the received signal.

## REFERENCES

- [1] L. R. Varshney, "Transporting information and energy simultaneously," in *2008 IEEE international symposium on information theory*. IEEE, 2008, pp. 1612–1616. [Online]. Available: <https://doi.org/10.1109/ISIT.2008.4595260>
- [2] G. Vieraalingam and R. Ramanathan, "Parametric study of rf energy harvesting in swipt enabled wireless networks under downlink scenario," *Procedia Computer Science*, vol. 143, pp. 835–842, 2018. [Online]. Available: <https://doi.org/10.1016/j.procs.2018.10.380>
- [3] R. Zhang, R. G. Maunder, and L. Hanzo, "Wireless information and power transfer: From scientific hypothesis to engineering practice," *IEEE Communications Magazine*, vol. 53, no. 8, pp. 99–105, 2015. [Online]. Available: <https://doi.org/10.1109/MCOM.2015.7180515>
- [4] X. Zhou, R. Zhang, and C. K. Ho, "Wireless information and power transfer: Architecture design and rate-energy tradeoff," *IEEE Transactions on communications*, vol. 61, no. 11, pp. 4754–4767, 2013. [Online]. Available: <https://doi.org/10.1109/TCOMM.2013.13.120855>
- [5] S. Kirthiga and M. Jayakumar, "Performance of dualbeam mimo for millimeter wave indoor communication systems," *Wireless personal communications*, vol. 77, no. 1, pp. 289–307, 2014. [Online]. Available: <https://doi.org/10.1007/s11277-013-1506-0>
- [6] G. Dhanesh, A. Rydberg, E. Ojefors *et al.*, "Design of millimeterwave micro-machined patch antennas for wlan applications using a computationally efficient method," in *2001 31st European Microwave Conference*. IEEE, 2001, pp. 1–4. [Online]. Available: <https://doi.org/10.1109/EUMA.2001.338902>
- [7] S. A. Rao, N. Kumar *et al.*, "Characterization of mmwave link for outdoor communications in 5g networks," in *2015 International Conference on Advances in Computing, Communications and Informatics (ICACCI)*. IEEE, 2015, pp. 44–49. [Online]. Available: <https://doi.org/10.1109/ICACCI.2015.7275582>
- [8] J. Kim, H.-S. Jo, K.-J. Lee, D.-H. Lee, D.-H. Choi, and S. Kim, "A low-complexity iq imbalance calibration method for quadrature modulator," *IEEE Transactions on Very Large Scale Integration (VLSI) Systems*, vol. 27, no. 4, pp. 974–977, 2018. [Online]. Available: <https://doi.org/10.1109/TVLSI.2018.2883758>
- [9] T. N. Nguyen, M. Tran, P. T. Tran, P. T. Tin, T.-L. Nguyen, D.-H. Ha, and M. Voznak, "On the performance of power splitting energy harvested wireless full-duplex relaying network with imperfect csi over dissimilar channels," *Security and Communication Networks*, vol. 2018, 2018. [Online]. Available: <https://doi.org/10.1155/2018/6036087>
- [10] Y. Chen, *Energy Harvesting Communications: Principles and Theories*. John Wiley & Sons, 2019.
- [11] D. N. K. Jayakody, J. Thompson, S. Chatzinotas, and S. Durrani, *Wireless information and power transfer: A new paradigm for green communications*. Springer, 2017. [Online]. Available: <https://doi.org/10.1007/978-3-319-56669-6>
- [12] T. Wang, G. Lu, Y. Ye, and Y. Ren, "Dynamic power splitting strategy for swipt based two-way multiplicative af relay networks with nonlinear energy harvesting model," *Wireless Communications and Mobile Computing*, vol. 2018, 2018. [Online]. Available: <https://doi.org/10.1155/2018/1802063>
- [13] M. Sundaram and R. Ramanathan, "Performance optimization of rf energy harvesting wireless sensor networks," *Procedia computer science*, vol. 115, pp. 831–837, 2017. [Online]. Available: <https://doi.org/10.1016/j.procs.2017.09.165>
- [14] F. Jameel, A. Ali, and R. Khan, "Optimal time switching and power splitting in swipt," in *2016 19th International Multi-Topic Conference (INMIC)*. IEEE, 2016, pp. 1–5. [Online]. Available: <https://doi.org/10.1109/INMIC.2016.7840157>
- [15] D. K. Nguyen, D. N. K. Jayakody, S. Chatzinotas, J. S. Thompson, and J. Li, "Wireless energy harvesting assisted two-way cognitive relay networks: Protocol design and performance analysis," *IEEE Access*, vol. 5, pp. 21 447–21 460, 2017. [Online]. Available: <https://doi.org/10.1109/ACCESS.2016.2644758>
- [16] S. Q. Nguyen, H. Y. Kong *et al.*, "Performance analysis of energy-harvesting relay selection systems with multiple antennas in presence of transmit hardware impairments," in *2016 International Conference on Advanced Technologies for Communications (ATC)*. IEEE, 2016, pp. 126–130. [Online]. Available: <https://doi.org/10.1109/ATC.2016.7764758>
- [17] T. Schenk, *RF imperfections in high-rate wireless systems: impact and digital compensation*. Springer Science & Business Media, 2008. [Online]. Available: <https://doi.org/10.1007/978-1-4020-6903-1>
- [18] Y. Li, *In-Phase and Quadrature Imbalance: Modeling, Estimation, and Compensation*. Springer Science & Business Media, 2013. [Online]. Available: <https://doi.org/10.1007/978-1-4614-8618-3>
- [19] L. Anttila, M. Valkama, and M. Renfors, "Blind compensation of frequency-selective iq imbalances in quadrature radio receivers: Circularity-based approach," in *2007 IEEE International Conference on Acoustics, Speech and Signal Processing-ICASSP'07*, vol. 3. IEEE, 2007, pp. III–245. [Online]. Available: <https://doi.org/10.1109/ICASSP.2007.366518>
- [20] T. D. P. Perera and D. N. K. Jayakody, "Analysis of time-switching and power-splitting protocols in wireless-powered cooperative communication system," *Physical Communication*, vol. 31, pp. 141–151, 2018. [Online]. Available: <https://doi.org/10.1016/j.phycom.2018.09.007>
- [21] W. Chien, C.-C. Chiu, Y.-T. Cheng, W.-L. Fang, and E. H. Lim, "Multi-objective function for swipt system by sadde," *Applied Sciences*, vol. 10, no. 9, p. 3124, 2020. [Online]. Available: <https://doi.org/10.3390/app10093124>
- [22] S. Arzykulov, G. Naurzybayev, T. Tsiftsis, and M. Abdallah, "Error performance of wireless powered cognitive relay network with

- interference alignment,” in *IEEE PIMRC*, pp. 1–5. [Online]. Available: <https://doi.org/10.1109/PIMRC.2017.8292459>
- [23] Y. Zhao, J. Hu, A. Xie, K. Yang, and K.-K. Wong, “Receive spatial modulation aided simultaneous wireless information and power transfer with finite alphabet,” *IEEE Transactions on Wireless Communications*, vol. 19, no. 12, pp. 8039–8053, 2020. [Online]. Available: <https://doi.org/10.1109/TWC.2020.3019011>