

Non-Invasive Hemoglobin Monitoring Device Using K-Nearest Neighbor and Artificial Neural Network Back Propagation Algorithms

R. Munadi, S. Sussi, N. Fitriyanti, and D.N. Ramadan

Abstract—The invasive method of medically checking hemoglobin level in human body by taking the blood sample of the patient requiring a long time and injuring the patient is seen impractical. A non-invasive method of measuring hemoglobin levels, therefore, is made by applying the K-Nearest Neighbor (KNN) algorithm and the Artificial Neural Network Back Propagation (ANN-BP) algorithm with the Internet of Things-based HTTP protocol to achieve the high accuracy and the low end-to-end delay. Based on tests conducted on a Noninvasive Hemoglobin measuring device connected to Cloud Things Speak, the prediction process using algorithm by means of Python programming based on Android application could work well. The result of this study showed that the accuracy of the K-Nearest Neighbor algorithm was 94.01%; higher than that of the Artificial Neural Network Back Propagation algorithm by 92.45%. Meanwhile, the end-to-end delay was at 6.09 seconds when using the KNN algorithm and at 6.84 seconds when using Artificial Neural Network Back Propagation Algorithm.

Keywords—invasive; non-invasive; K-Nearest Neighbor; Artificial Neural Network Back Propagation

I. INTRODUCTION

THE normality of Hemoglobin (Hb) level in human body is different by sex or gender and the characteristics of Hb in human body is highly fluctuating dependent upon the condition or activities. The Hemoglobin level in human body can be stated normal if the concentration of Hemoglobin in blood is in the range of 13.5 to 17 g/dL for male and 12 to 15 g/dL for female. The lack or the excess of hemoglobin level in the blood of human body can cause various diseases such as anemia due to the lack of hemoglobin and polycythemia due to the excess of hemoglobin. [1]. Monitoring the bleeding in post-surgery and autologous transfusion is conducted by monitoring the hemoglobin level. Hemoglobin (Hb) is a protein molecule in erythrocytes that act to carry the oxygen from the lungs to the body tissues. The hemoglobin carrying the oxygen is called as HbO₂ or Oxyhemoglobin, while the hemoglobin that does not carry the oxygen is called as DeoxyHemoglobin. The oxygen saturation (SpO₂) is the percentage of oxygen spread in all parts of body that has been carried by HbO₂.

Recently, the technique to measure the total level of hemoglobin in human body is invasive that is by manually

taking the blood sample from the patients and this – in addition to not giving a rapid result - is highly ineffective since the fingers must be soon medically treated to prevent any infections [2]. Another technique is non-invasive (without injuring the body of the patients) in which it is used to make the patients not to feel any pains during the Hb examination. This noninvasive method can prevent any bacteria contamination and the results of the hemoglobin level can be directly identified through LCD (Liquid Crystal Display). The noninvasive Hb measurement by using the multi wavelength and sensor pulse oximeter has been done. The sensor pulse oximeter can act to measure the percentage of hemoglobin (Hb) saturated with the oxygen in blood [3].

Based upon a number of previous studies, a noninvasive hemoglobin measuring device was made using the NodeMCU microcontroller, sensor pulse oximeter, ThingSpeak by applying the HTTP protocol and python programming based KNN algorithm and Artificial Neural Network Back Propagation algorithm. Those two algorithms used the training data and the digital input data from the sensor by seeing the amount of the accuracy values that could be achieved and by comparing the resulted end-to-end delay.

The rest of paper is organized as follows. Related work about this issue is described in Section II and the design of hemoglobin monitoring device is described in Section III. Further, Section IV presents the measurement and results of the analysis. Lastly, the conclusion of this study is presented in Section V.

II. RELATED WORK

The noninvasive method has been developed such as in Hb measurement by using the light wave and laser beam to determine Hb with non-invasive [4][5]. The use of multi-wavelength with the pulse oximeter sensor comes to be one of the ways in measuring the noninvasive Hb [6]. The detection of the oxygen saturation in blood with the reflection system uses the scheme of integrated MAX30100 Chip based design. This chip possesses photodiode accepting the reflection light and oxygen saturation is measured based upon the differences in reflection light intensity accepted. The detecting system of oxygen saturation had a quite good result and it is also beneficial due to the little dimension, low cost and portability [7].

R.Munadi, S.Sussi are with Department Telecommunication Engineering, School of Electric Engineering, Telkom University, Indonesia (email: rendymunadi@telkomuniversity.ac.id, sussiss@telkomuniversity.ac.id).

N.Fitriyanti is with Department Physics Engineering, School of Electric Engineering, Telkom University, Indonesia (email: nurwulanf@telkomuniversity.ac.id).

D.N.Ramadan is with Diploma of telecommunication technology, School of Applied Science, Telkom University, Indonesia (email: [dadannr@telkomuniversity.ac.id](mailto:dadanr@telkomuniversity.ac.id)).



Designing a series of sensors is an effort to measure hemoglobin using non-invasive method. The method used is by using a pair of photo-plethysmo-graphic (PPG) signals obtained from the finger using two monochromatic lights at 660nm (Red) and 940nm (IR) [8]. Meanwhile, in other research, two inputs, those are Impedance Plethysmography (IPG) determining the blood volume and optical sensor Photoplethysmography (PPG) determining light absorbance were required. To take the data, two optical sensors, i.e. a photodiode sensor (OPT-101) and a phototransistor (SFH. 3310) operating at a wavelength of 530nm were needed. The amount of hemoglobin concentration could be obtained from the value of the PPG/IPG ratio [9].

The non-invasive hemoglobin sensor system that has been developed can continuously measure the magnitude of the photoplethysmography (PPG) signal at a wavelength of 670 nm. The system made used an ARM processor as a controller and Light Emitting Diodes (LED) as a display of measurement results [10].

This study used the differences in absorption/transmission light signals in the red area and red infra between oxygenation (HbO₂) and reduced hemoglobin (HHb). To measure the accuracy in the hemoglobin concentration, it used two wavelengths, i.e. 1300 nm for the water absorption and 810 nm for the absorption of oxyhemoglobin and deoxyhemoglobin [11].

In addition, the study related to the development of the hemoglobin measurement noninvasively has the measuring devices not connected to the internet network but only display the data of the hemoglobin measurement in real time on the LCD screen [12].

Artificial Neural Network is a Deep Learning computation algorithm. The ANN algorithm implements the performance of a high human brain system in determining an action. This algorithm uses the node model and manages the expected learning management, enabling it to be able to be trained and result in the expected desire.

ANN Back Propagation is a network that has a high accuracy as it can do a learning and self-development. Such algorithm involves three phases in doing the feedforward from the input training pattern, calculation and weight adjustment. The process of Back-Propagation occurs in Hidden layer in a complex process [13]. The use of the algorithm of Artificial Neural Network Back propagation has a far better level of accuracy when being used to forecast the climate in some areas.

Other studies conducted a measuring technique by implementing one of machine learning algorithm that is K-Nearest Neighbor (KNN) with an aim to obtain the approach values from the measurement by doing the training data that will be processed and input on the android application [14]. Igorithm KNN was able to find out the sample of the k training that was closest to the test sample if the test sample was available. Therefore, KNN algorithm is simple to be applied with the result that is close to the fact meaning that it has a high accuracy value in addition to its little ratio of error [15].

KNN Algorithm is able to make an estimation of stock market prices including to uncover the market trends, identify the best time to purchase the shares, and even to be able to decide which share to be purchased and to plan the strategy of its investment [16]. The use of python programming is with a consideration that programming language can be easily embedded in the existing applications requiring a programmable interface. The advantage of Python programming language is that it has a large standard library such as creating the graphical user interfaces, and connecting to databases [17]. Meanwhile, the use of the

ThingSpeak data base has been used in many monitoring systems, say, in the system of smart community monitoring – the media that work as intermediaries between smart homes and smart cities. In the smart community monitoring system, the ThingSpeak IoT platform is used to receive data from the smart home with the protocol used by MQTT in which the data are stored in a database and visually demonstrated on the ThingSpeak Webpage [18].

III. DESIGN OF HEMOGLOBIN MONITORING DEVICE

A. Research System Design

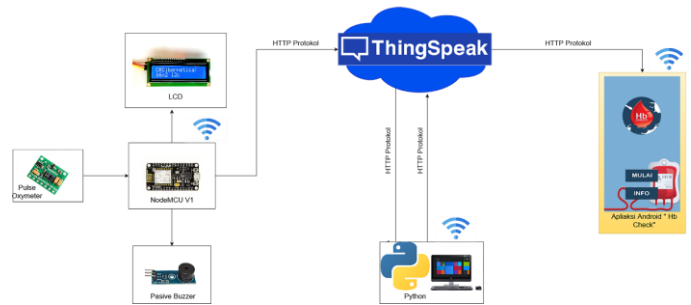

Fig. 1. The diagram of Hemoglobin Monitoring Device System

The design of the research system consists of microcontroller, Thing Speak, Python programming, and android application and HTTP used as the protocol as illustrated in Figure 1. The sensor used was MAX30100 resulting in SpO₂ value and Node MCU V1 would send the data to the Things peak. The data sending from microcontroller filled 2 fields in ThingSpeak in which the first field was SpO₂ containing the values and second field was the Hb value with 0 value.

Python programming processed and updated the SpO₂ value in Thing Speak. In Thing Speak, the value to be read was the last updated values. The process of predicting the Hb values was done in accordance to the rules obtained in the training of Algorithms of ANN Back Propagation and KNN. The Hb value as the results of the prediction furthermore was updated to the second field and 0 value was for the first field. The side of android application would read the value of the second field and define the status of the body condition when user did the Hb checking.

B. The Design of Device

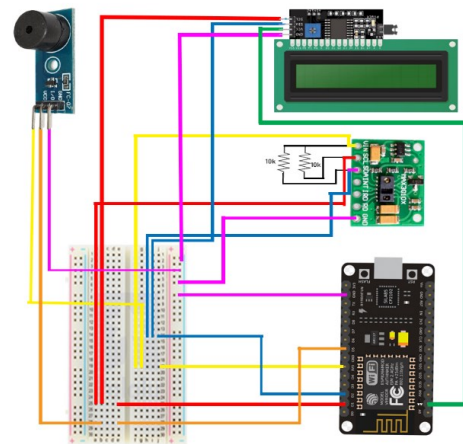

Fig. 2. The Scheme of Hardware Design

The hardware in the hemoglobin monitoring system consists of Node MCU as the microcontroller that has been in the module of ESP8266 *Wi-Fi* that would be connected to the MAX30100 sensor, Buzzer, and LCD, as seen in Figure 2. Two resistors of 10kΩ were added in the MAX30100 sensor installed in parallel. The specification of the hardware is presented in detail in Table 1 and the hardware design is illustrated in Figure 3.

Table I
Hardware required

No	Hardware	Specification
1	Node MCU ESP8266	3.3 V
2	Module Buzzer	Passive Buzzer
3	LCD	2 x 16
4	Jumper	female to male
5	Jumper	male to male
6	PCB	double layer
7	Laptop Lenovo	Core i7, Ram 8 Gb
8	Resistor	10kΩ
9	Pulse Oximeter (Max30100)	3,3 v
10	Power Supply	11200 mAh

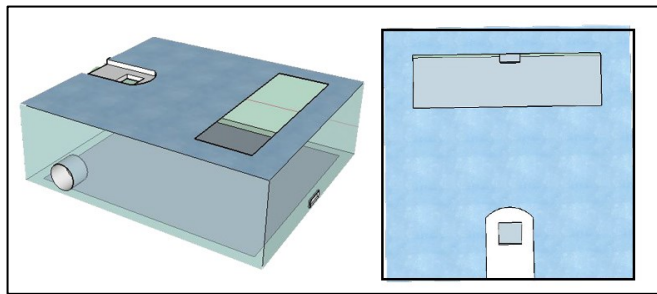

Fig. 3. The Design of the Hemoglobin Monitoring Device Package

C. The Design of Android Application

In the android application, the users can see the level of Hb, know the information about Hb and see the previous record of Hb. The activity of the use of android application is presented in Figure 4 consisting of the main menu, monitor menu and information menu.

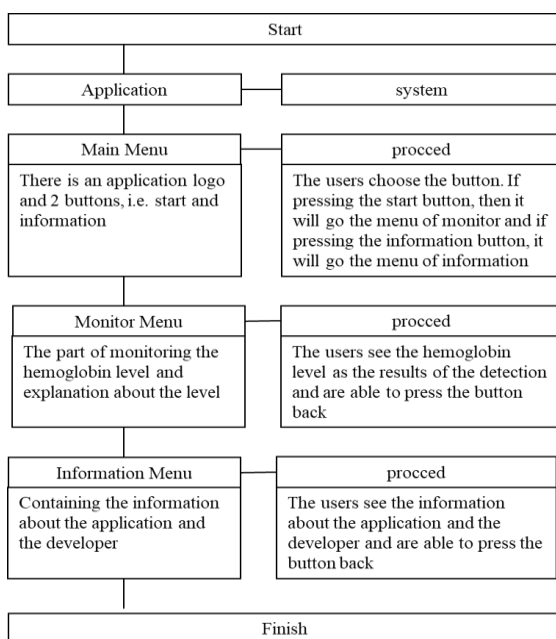

Fig. 4. Diagram of the application use activity

User interface (UI) in android application consists of 3 scenes. In this first scene, the users can get the information from the application and devices used. In the second scene, there is a logo of application to start and give information about Hb and in third scene there is a feature for reading the Hb values with the provision of one number after comma, and the button reset and feature of information about Hb values measured based on gender. Figure 5 illustrates the display of UI of hemoglobin monitoring application.



Fig 5. User Interface (UI) of Hb Application

D. Testing Scenario

The system of ANN *Back Propagation* and KNN would be tested purposely to get a better performance. The test was conducted in the invasive Hb data of the forefinger of the left hand, on the previous data searching, as listed in Table 2 for testing the ANN algorithm and Table 3 for testing the KNN algorithm.

Table II

Hb prediction system test data for ANN Back Propagation algorithm

No	SpO2	invasive Hb
1	98	14.3
2	96	14
3	96	14
4	98	14.5
5	96	14
6	98	14.9
7	96	15
8	96	15.9
9	97	15.1
10	96	13.9
11	91	14.1
12	98	16.5
13	97	12.9
14	98	14.7
15	97	15.4
16	98	13.8
17	98	14.4
18	92	13.9
19	94	13.8
20	96	14.3
21	94	15.8
22	97	12.5
23	99	16.7
24	90	11.1

Parameters that would be changed in the test using the algorithm of ANN *Back Propagation* were the number of epochs and hidden nodes as the most important parts in seeking the accuracy values of the devices. The number of suitable epochs and hidden nodes would be obtained by calculating the values of the difference and the value of accuracy of Hb from

each process of the test in the parameters of epochs and hidden nodes determined.

Table III
Hb prediction system test data for KNN algorithm

No	SpO2	Invasive Hb
1	98	15.9
2	93	13.9
3	96	13.8
4	97	11.9
5	99	12.7
6	97	13.2
7	92	12.5
8	95	13.6
9	99	14.7
10	94	15.2
11	97	14.2
12	94	16.5
13	97	14.5
14	97	16

Meanwhile, the parameters that would be changed in the test using KNN algorithm was by conducting the process of the regression of values $k=1$ to $k=10$ as the most important parts in seeking the accuracy value of the device. Having obtained the regression of $k=1$ to $k=10$, it also needed to calculate the difference value and the value of Hb accuracy from each testing process to the parameters determined.

The difference values and the accuracy values were obtained from the comparison between invasive Hb and noninvasive Hb in both algorithm of ANN Back Propagation and KNN with Equation 1.

$$\text{Difference Hb} = \text{invasive Hb} - \text{noninvasive Hb} \quad (1)$$

The seeking of the difference value of Hb could be determined to obtain the accuracy value from the Hb monitoring device. Equation 2 as the formula to determine the accuracy value in the Hb monitoring device is presented below.

$$\text{Accuracy value Hb} = \frac{\text{invasive Hb} - \text{noninvasive Hb}}{\text{invasive Hb}} \quad (2)$$

IV. MEASUREMENT AND RESULTS ANALYSIS

A. Accuracy Measurement Result

1) K-Nearest Neighbor (KNN) Algorithm

K-Nearest Neighbor (KNN) is a very popular supervised learning algorithm both for Data Mining and for Statistic due to its simple implementation and significant classification process. In study [16], an algorithm was divided into 2 types of supervised learning: regression and classification that would predict a certain object based upon the approach of training data from a number of samples.

The rules of this algorithm were only to maintain all training data during the sampling and determine for each class represented by the majority label from K-Nearest Neighbor (KNN) in the process of determination of the training data. 1-Nearest Neighbor is a form of the simplest KNN when $K=1$. The test of this algorithm was through the test of parameter K with the training data given. Meanwhile, for the testing data in the form of input value of SpO2 level to be input into the system to obtain the value of noninvasive Hb level. The results of the high accuracy was found in the value of $K=2$, i.e. 93.5%; hence, the value of $K=2$ would be used to figure out how accurate the approach of Hb values between device system (noninvasive) and the original device (invasive).

As shown in Table 4, it was found that the noninvasive Hb value in the designed monitoring device had the different Hb values for adjusting the input value of SpO2 to predict the Hb values obtained.

Table IV
Accuracy of KNN and ANN BP Algorithm vs. SPO2

No	SPO2	Invasive Hb KNN	Invasive Hb ANN BP	HB Non-I KNN	Hb Non-I ANN BP	Accuracy KNN	Accuracy ANN BP
1	90		11.1		14.18		72.21
2	91		14.1		14.18		99.4
3	92	12.5	13.9	14.1	14.18	87.2	97.95
4	93	13.9		13.02	14.18	93.7	
5	94	16.5	15.8	15.95	14.18	96.67	89.77
6	95	13.6		13.3	14.18	97.79	
7	96	13.8	14.3	14.25	14.18	96.74	99.19
8	97	14.2	15.1	14.22	14.18	99.84	93.93
9	98	15.9	14.3	14.36	14.18	90.31	99.19
10	99	14.7	16.7	13.8	14.18	93.87	84.93

2) ANN Back Propagation Algorithm.

Artificial Neural Network Back Propagation (ANN Back Propagation) Algorithm refers to a network that has a high accuracy for being able to learn and improve the self-competence. The process of *Back-Propagation* occurs in the *Hidden layer* with a complex process. This algorithm has two processes: forward process – a multiplication process of the input values, weight and bias. The second process is the backward process if the output values are not suitable with the output values of training and has the high loss values. Hence, this process will again do the update to its hidden nodes. The formula used for the Hb monitoring device is the results of the highest accuracy and the lowest loss values achieved in value 9 hidden node and *epoch* 500.

As seen in Table 4, the invasive Hb values in the designed monitoring device had an equal Hb value, i.e. 14.18 g/dl compared to the values of a number of inputs of SPO2; while the maximum accuracy was 99.4%. Such condition could be determined by the less or not varying training data. It was also due to the input data of training did not have any significant difference, thus making the learning pattern of the learning rule not maximal as the system in learning the pattern was almost similar.

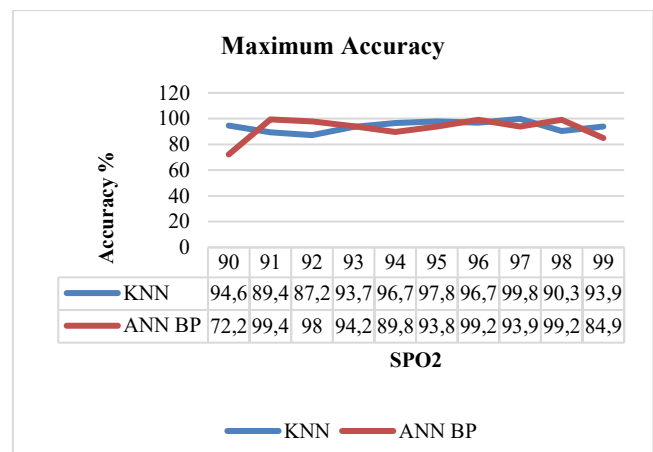

Fig. 6. The graph of accuracy for the SPO2 values

As seen in Figure 6, by comparing the results obtained based on the accuracy values of KNN algorithm to ANN Back Propagation algorithm, KNN algorithm was found to have the

better results with the accuracy of 94.01% on average. This was because the number of samples of KNN algorithm was fewer in addition to the relatively little difference in the value between invasive Hb and non-invasive one.

B. Accuracy Measurement Result

1) K-Nearest Neighbor (KNN) Algorithm.

The delay measurement in the entire system in the monitoring device was conducted by using *stopwatch*. Delay was measured from the process of reading the SpO2 value until sending the Hb values on the Hb Check application. The process of delay measurement was conducted through 10 testing. The average values of entire delay measurement were at 6.09 sec. The Delay was measured from the process of reading the sensor until the Hb values could be monitored in the Android application or HB check. The Delay was in the poor category as the values were above 0.45 sec. this was determined by HTTP protocol in which the process of *request* and *reply* required time and the process of predicting the Hb level also required time as when the SpO2 values were input into the server, the values must be firstly processed in the python using the ANN *back propagation* algorithm before being sent to the Hb check application. However, in this case, the sending of the Hb values with delay 6.09 sec did not bring any effects.

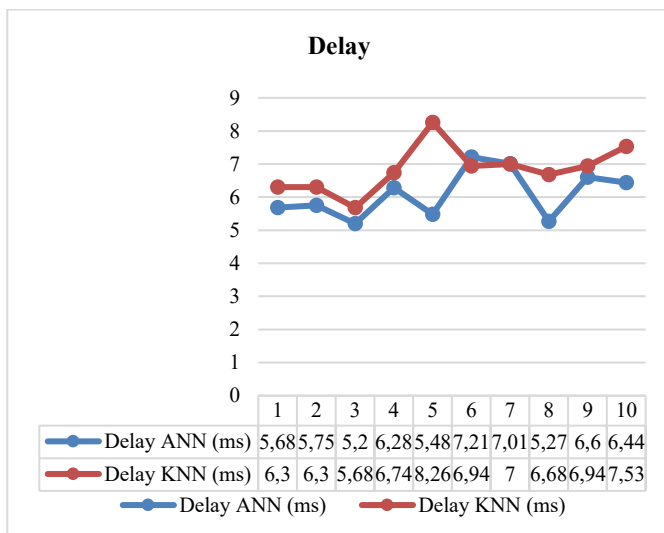

Fig. 7. The graph of end-to-end delay to the number of tests

2) KNN Algorithm

The measurement of the end-to-end delay in the monitoring device system was conducted from the process of SpO2 values sent by Node MCU until the Hb values were sent to the Android application. This process was conducted by 10 testing.

The results of the 10-time the delay measurement showed the average delay at 6.84 sec. This delay was the end-to-end delay, meaning the delay from the sensor reading process to the display of the Hb value in the android application. The amount of delay obtained was influenced by the prediction process of Hb value, which required time when the SpO2 value entered to the Cloud server and simultaneously was processed by python programming using the KNN algorithm before sending to the Android application. In addition, the amount of delay was determined by the use of the HTTP protocol that would conduct the request and reply process, which also required time.

However, with a delay in the delivery process of 6.84 sec, there was no effect in the designed Hb monitoring device.

As seen in Figure 7, by comparing the results obtained based on the values of end-to-end delay towards the number of testing conducted from KNN algorithm and ANN Back Propagation algorithm, it was found that ANN back propagation algorithm was found better as it resulted in the average delay of 6.09 sec. This was due to the training input data had no any significant difference making the process faster and ANN Back Propagation algorithm required the faster process.

V. CONCLUSION

In this study, Noninvasive Hb monitoring device has been made by implementing the use of Artificial Neural Network Back Propagation Algorithm and K-Nearest Neighbor to obtain the best accuracy value and the lowest value of end-to-end delay. K-Nearest Neighbor Algorithm was found able to give the average value of accuracy by 94.01%; meanwhile, the Artificial Neural Network Back Propagation algorithm resulted in the average accuracy value by 92.45%. The amount of end-to-end delay in the K-Nearest Neighbor algorithm was 6.09 seconds – lower than the results obtained from Artificial Neural Network Back Propagation algorithm by 6.84 seconds. Based on the accuracy value and the end-to-end delay, then it can be stated that K-NN algorithm had a better performance in comparison to the Artificial Neural Network Back Propagation algorithm. These could bring some effects on the results of both two algorithms in the testing of noninvasive monitoring device in terms of accuracy value and the value of end-to-end delay for instance the high number of samples and training data, python programming and the use of HTTP protocol as the protocol in the phase of service. For the next research phase it is to perform the integration of the noninvasive hemoglobin measurement device system with any internet of things based algorithm to make it as the ready-make system.

REFERENCES

- [1] K. S. Pavithra, X. Anitha Mary, K. Rajasekaran, and R. Jegan, "Low Cost Non-Invasive Medical Device for Measuring Hemoglobin," *Proc. IEEE Int. Conf. Innov. Electr. Electron. Instrum. Media Technol. ICIEEIMT 2017*, vol. 2017-January, pp. 197–200, 2017. <https://doi.org/10.1109/ICIEEIMT.2017.8116834>
- [2] S. Chugh and J. Kaur, "Non-invasive hemoglobin monitoring device," *2015 Int. Conf. Control. Commun. Comput. India, ICCCI 2015*, no. November, pp. 380–383, 2016. <https://doi.org/10.1109/ICCC.2015.7432925>
- [3] P. Raikhram, R. Kumar, R. K. Shah, M. Hazarika, and R. K. Sonkar, "Non-invasive blood components measurement using optical sensor system interface," *2018 3rd Int. Conf. Microw. Photonics, ICMAP2018*, vol. 2018-Janua, no. Icmmap, pp. 1–2, 2018. <https://doi.org/10.1109/ICMAP.2018.8354638>
- [4] E. Kusumawati, N. Lusiana, I. Mustika, S. Hidayati, and E. N. Andyarini, "The Differences in the Result of Examination of Adolescent Hemoglobin Levels Using Sahli and Digital Methods (Easy Touch GCHb)," *J. Heal. Sci. Prev.*, vol. 2, no. 2, pp. 95–99, 2018. <https://doi.org/10.29080/jhsp.v2i2.128>
- [5] R. A. Buda and M. M. Addi, "A portable non-invasive blood glucose monitoring device," *IECBES 2014, Conf. Proc. - 2014 IEEE Conf. Biomed. Eng. Sci. "Miri, Where Eng. Med. Biol. Humanit. Meet."*, no. December, pp. 964–969, 2014. <https://doi.org/10.1109/IECBES.2014.7047655>
- [6] H. Ali, F. Bensaali, and F. Jaber, "Novel Approach to Non-Invasive Blood Glucose Monitoring Based on Transmittance and Refraction of Visible Laser Light," *IEEE Access*, vol. 5, pp. 9163–9174, 2017. <https://doi.org/10.1109/ACCESS.2017.2707384>

- [7] Jiayi Wan, Yuhua Zou, Ye Li, Jun Wang. "Reflective type blood oxygen saturation detection system based on MAX30100", 2017 International Conference on Security, Pattern Analysis and Cybernetics (SPAC). <https://doi.org/10.1109/SPAC.2017.8304350>
- [8] K.S.Pavithra , X Anitha Mary , K. Rajasekaran , R.Jegan, "Low Cost Non-Invasive Medical Device For Measuring Hemoglobin", Proceedings of IEEE International Conference on innovations in Electrical, Electronics, Instrumentation and Media Technology ICIEEIMT 17, 2017, pp.197-200. <https://doi.org/10.1109/ICIEEIMT.2017.8116834>
- [9] Brinda Desai, Uttam Chaskar, "Comparison of optical sensors for non-invasive hemoglobin measurement", International Conference on Electrical, Electronics, and Optimization Techniques (ICEEOT) – 2016. <https://doi.org/10.1109/ICEEOT.2016.7755085>
- [10] Raid Saleem Al-Baradie, Anandh Sam Chandra Bose,"Portable Smart Non-Invasive Hemoglobin Measurement System", 2013 10th International Multi-Conference on Systems, Signals & Devices (SSD) Hammamet, Tunisia, March 18-21, 2013. <https://doi.org/10.1109/SSD.2013.6564149>
- [11] U. Timma, G. Leena, E. Lewisa, D. McGrathb, J. Kraitlc and H. Ewald , "Non-Invasive Optical Real-time Measurement of Total Hemoglobin Content", ELSEVIER, Proc. Eurosensors XXIV, September 5-8, 2010, page 488–491. <https://doi.org/10.1016/j.proeng.2010.09.153>
- [12] I. M. M. Yusoff, R. Yahya, W. R. W. Omar, and L. C. Ku, "Noninvasive cholesterol meter using Near Infrared sensor," *Proc. - 2015 Innov. Commer. Med. Electron. Technol. Conf. ICMET 2015*, no. November, pp. 100–104, 2016. <https://doi.org/10.1109/ICMETC.2015.7449581>
- [13] N. A. Al-Sammaraie, "Classification and diagnosis using back propagation Artificial Neural Networks (ANN) algorithm," *2018 Int. Conf. Smart Comput. Electron. Enterp.*, pp. 1–5, 2018. <https://doi.org/10.1109/ICSCEE.2018.8538383>
- [14] S. Imandoust and M. Bolandraftar, "Application of k-nearest neighbor (knn) approach for predicting economic events: Theoretical background," *Int. J. Eng. Res. Appl.*, vol. 3, no. 5, pp.605–610, 2013. www.ijera.com
- [15] P. Mulak and N. Talhar, "Analysis of Distance Measures Using K-Nearest Neighbor Algorithm on KDD Dataset," *Int. J. Sci. Res.*, vol. 4, no. 7, pp.2319–7064, 2015.
- [16] S B Imandoust, Mohammad Bolandraftar,"Application of K-Nearest Neighbor (KNN) Approach for Predicting Economic Events: Theoretical Background." *Int. Journal of Engineering Research and Applications, Vol. 3, Issue 5, Sep-Oct 2013, pp.605-610.* www.ijera.com
- [17] Kalyani Adawadkar. "Python Programming-Applications and Future", *Scientific Journal of Impact Factor (SJIF)*, Special Issue SIEICON-2017, April -2017.
- [18] David Nettikadan and Subodh Raj M.S, "Smart Community Monitoring System using ThingSpeak IoT Platform.", *International Journal of Applied Engineering Research*, Volume 13, Number 17 (2018) pp. 13402-13408.