

Design Multitasking Device to Protect and Control of Electrical Home Appliances

Jabbar Shatti Jahlool

Abstract—In this research, a multi-tasking protection and control device has been designed and implemented has the ability to control and manage automatically the supply of electrical power from various sources to electric appliances connected to the light loading line (3L). At the same time, providing comprehensive protection for the appliances by delaying the supply of power for short period of time during the moment of conversion from one source to other in order to protect it from damage. The mechanism working of the proposed device depends on detecting the problem, diagnosing it and choosing the appropriate solution for it, and then organizing the supply from the appropriate source, and as a result ensure power supply to home appliances.

Keywords—protection system; arduino board; control system; national grid; electrical appliances; automatic phase selector

I. INTRODUCTION

IN general terms, in Iraq, the three feeders lines (L1, L2 and L3) of the national grid for electrical power distributed inside the houses in such a way that is the light-load appliances like lighting lamps, television, freezer, refrigerator, washing machine, surveillance cameras, etc. are connected to one of the electrical power supply lines called light load line (3L). While the other two lines are usually intended for heavy-load devices such as air conditioners heaters and others. So the focus is on 3L, due to the fact that the power supply of this line comes from various sources such as the national grid, diesel generator, solar energy, UPS and others. The goal is that the necessary appliances connected to this line should continue to operate for the longest possible period of time.

Any malfunction on the 3L leads to the suspension of the operation of the devices or the malfunction of some of them. Therefore, it is necessary to provide an effective and automatic protection mechanism for this line when switching from various processing sources to maintain the devices connected to it.

For the purpose of ensuring continued supply of electrical energy, three sources are used for this purpose, which are solar, mains grid and diesel generator, switching between these three sources are applied by using automatic phase selector, but, this device does not take into account the voltage levels of the power supply sources, as well as the absence of a delay time in the transition from one source to another [1]. The influence of the connection of a group of parallel household

electrical appliances on the effective protection distance of the system. The study found that there is directness where the SPD protection distance increases when many household appliances are connected in parallel [2].

Design, simulation and implementation of automatic phase selector and changeover switch for 3-phase supply are used, but this design don't limited or explain the amount of load can be used for this circuit [3]. Three phase supply is connected to conductor and (12 V) gear motor. any one of the three phases is touch by the conductor. The changing from one phase to another is done via the connected the gear motor to conductor in a way that allows that change. But the weakness is in the use of an automatic selector based on a gear motor in which the mechanical movement is subject to defects in the position of the mechanical parts [4].

Construction of a real laboratory automatic transfer switch (ATS) and three phase selector by using electromechanical relays and comparators are implemented [5]. Automatic method for detection and correction the fault in three-phase electrical power feeders design depend on using microcontroller are implemented [6]. A real time auto phase selector was design that automatically selecting the right active phase from the three national power grid. And as a result prove continuity of supply the power to the customer [7].

Provide protection of home appliances in low voltage (LV) distribution system then to avoid their failure due to abnormal operating conditions. This by monitoring over voltage, under voltage and over current conditions [8]. Malfunctions and failures in the supply of electrical energy cause disturbance to the reliability of the quality and safety of the power system. Therefore, having a protection system for electrical appliances dispels these fears and hassles and is therefore an integral part of power systems [9,10].

The current and excess current in the electrical power system is the condition in which the value is greater than the required value, and this process of course leads to excessive heat generation in the conductive wire of the electricity, which leads to the result of damage to electrical equipment [11,12].

In this paper, design of a multi-tasking protection system was developed to organize and controls the process of supplying energy to the 3L from various sources based on the planned priorities.

The process of switching from one source to another occurs in case of stopping the current source with the highest priority and so on. Other hand, providing an appropriate period of time for moving from one source to another in order to protect household appliances from damage resulting from sudden conversion, especially devices that contain compressors such as a refrigerator, freezer and a water cooler. Other task of the device is that it works without human intervention, thereby protecting it from rounding to lethal power sources. Also

This work was supported by the Dijlah University College, Computer Technique's Engineering Department.

Jabbar Shatti Jahlool is with Dijlah University College, Computer Technique's Engineering Department, Baghdad, Iraq (e-mail jabbar.shatti@duc.edu.iq).



ensuring the continuity of supplying energy to customers at all times and conditions, as well as not requiring the use of individual protective devices for each home appliance.

II. PROPOSED SYSTEM DESCRIPTION

The proposed design divided in to multi units, each unit responsible on the specific function. Some of these units are implemented through hardware, while the others are implemented jointly through the hardware and software. As a result, the sum of these units is covered the whole system requirements. Fig.1 represents the block diagram of the proposed system design.

Arduino uno board is the central unit of the system. This board is used in large applications, because ease of the handling, connection and programming. Important things and other features generate a desire of direction to use such devices, like a very wide range of applications from simple project to complex, high quality, low price and ease of availability without any trouble [13]. It is an ideal solution for different control applications, because it have (14) inputs digital lines and (6) analog lines. The board have 8 bit microcontroller based on the ATmega328, 16 MHz ceramic resonator, SRAM 2kb and flash memory 32kb.[14].

The A.C voltage level sensing unit will received three lines A.C 220 volt inputs and then output three lines with low level D.C voltages equivalent to the corresponding of input phases of power system. These low level lines connect to the three analog input ports (A0, A1, and A2) of the Arduino board.

After implement the algorithm, the system will output correct decision in the form of five control signals from Arduino digital ports (1, 2, 3, 9,10). These signals denoted as follows:

- (L1_C) the control signal for line one (phase 1).
- (L2_C) the control signal for line two (phase 2).
- (L3_C) control signal for line three (phase 3).
- (VR_C) control signal for voltage regulator.
- (UPS_C) control signal for UPS.

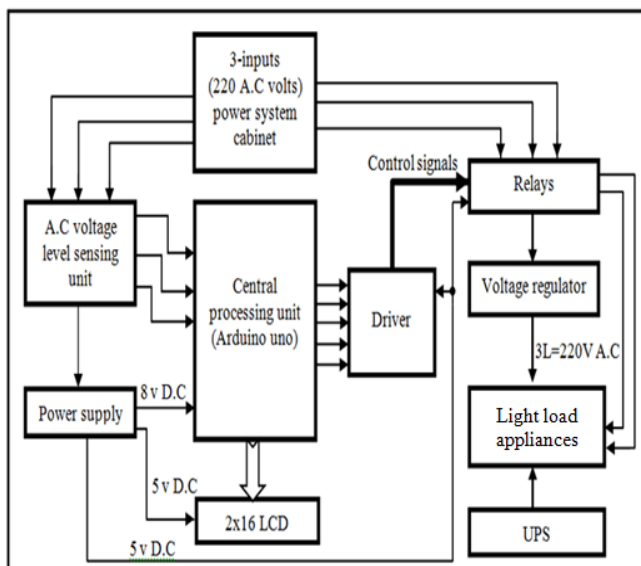

Fig 1. Proposed system block diagram

These five control signals will be used to select the required right source for electric power connected to 3L through the ULN2003 driver and relays. Power supply consists of different

voltage regulators integrated circuit to supply all system devices with appropriate required voltage. The 16x2 liquid crystal device (LCD) used to display the system states. The five light emitting diodes (LED) are used to indicate the effectiveness of control signals, which one is effective or not.

III. SYSTEM FLOW CHART

The algorithm approach to the proposed design start by the continuity testing the level voltage of phase one, if its right value within the standard level, directly convert the power source from this phase to output 3L, this is by setting the control signal (L1_C) and don't care the other two control signals (L2_C), (L3_C). At the same time, the LCD will display the word (ph2=d.c ph3=d.c and ph1=ok). where the F for fault, d.c for don't care and ok for right. While when there is a fault in this phase, the process converts to check the level voltage of second phase, if its right value within the standard level, the supply source of 3L will change to L2, this occur by setting the control signal (L2_C) and don't care the control signal (L3_C) and disable (L1_C). At the same time, the LCD will display (ph1=F,ph3=d.c and ph2=ok).

The same testing process is performed on there'd phase, when there is a defect in the first and second phases. If its right value within the standard level, the supply source of 3L will change to L3, this is by setting the control signal (L3_C). At the same time, the LCD will display (ph1=F,ph2=F and ph3=ok).

For the case, when the level voltage of all the three lines of power system are lower or higher than the standard level then the feeding of 3L turns from the voltage regulator by setting the control signal (VR_C).

The final case when all the power line is cutting or stopping, the supply of 3L will change to UPS though setting the control signal (UPS_C). These successive checks are detailed explain in the flowchart of Fig. 2.

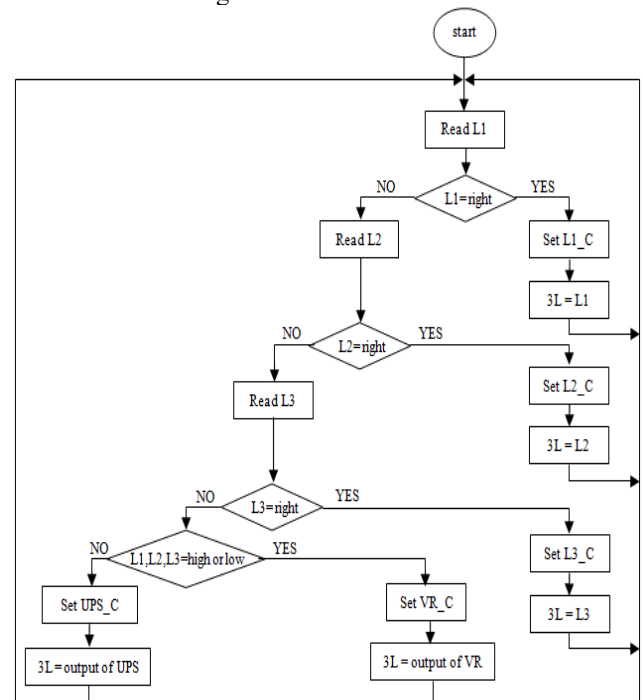

Fig 2. Proposed system flow chart

IV. CIRCUIT CONNECTION AND IMPLEMENTATION

The schematic diagram of the proposed system is shown in the Fig. 3.

The central processing units represented by Arduino board through which the design will process all system analysis to output right decision depend on the proposed algorithm by using the sketch Arduino software. The software used for developed the sketch is called the Integrated Development Environment IDE [15, 16].

The A.C voltage level sensing unit consist of the following components: 3-step down transformers (220/12 volt 400 mA or 1 Amp), 3-bridge rectifier, 470µF capacitor as a filter, 2.2 kΩ, 1.5 kΩ for each phase as a divider to down the D.C voltage from 12 v D.C to less than 5 v D.C which are denoted as (L1d.c, L2d.c and L3d.c) corresponding to three input phases. These three D.C voltages will connect to Arduino analog inputs (A0, A1 and A2).

The operating code is writing and downloads to Arduino board for performs the calculation and analysis process. After testing, reading and analyzing each of the three input states, a decision will be issued specifying the type of power supply source that will be connected to 3L. The components inside the red box of the circuit diagram that are (U1, U2, U5, U7, RL1 and RL2), it represents the unit responsible for supply all the components of the system, including the arduino board with required voltages.

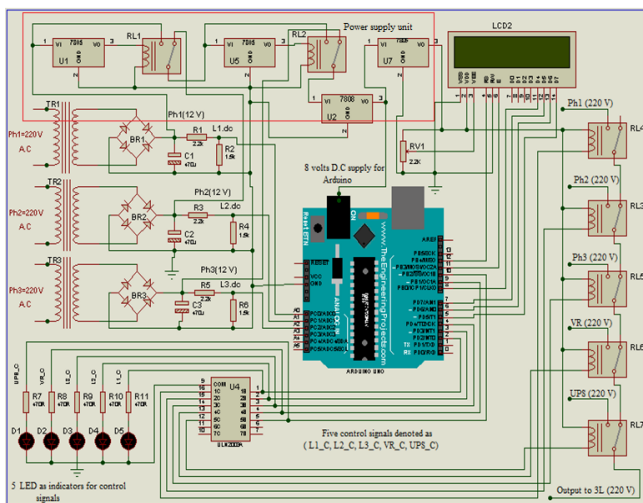

Fig 3. Final proposed circuit diagram

The components (D1, D2, D3, D4, D5, R7, R8, R9, R10, R11) are used as indicator for the output control signals to detect each one is active or not. The components (U4, RL3, RL4, RL5, RL6, RL7) are used to control the conversion of the appropriate electrical power source 220 volts A.C to 3L depend on decision output by system algorithm.

The ULN2003 IC, which is an array of seven NPN Darlington pairs. This IC is used for driving the relays because its high-voltage and high-current, it has the ability to sustaining a load of 500 mA, 50 volts output [17,18]. Finally the LCD is used to display the system status.

V. TEST AND RESULTS:

Before actually connecting the prototype and before entering into the complexities of the physical connection, it is necessary to use appropriate tools for the purpose of carrying out possible initial checks and ensuring that all components of the system are operating as planned. In order to achieve this, a specialized and appropriate simulation program should be selected and used. Therefore, A Proteus 8 professional simulator program chosen for the following reasons: Repetitive use due to its efficiency in checking the operation of analog and digital systems. The simulation gives results similar to the results of the final tests of physical circuits and also as a result of its uses in a wide range of applications for these purposes [19, 20].

Connecting the prototype in the normal operating state is shown in the Fig. 4 it was neglected to address the voltage regulator and UPS device because they are external devices ready and only need to control their operation through the proposed device. The control signals responsible for operating the two devices are: (VR_C) responsible for control the voltage regulator device subscribing with relay (RL6). The (UPS_C) control signal, responsible for control UPS device subscribing with relay (RL7). Therefore, the checks were focused on the three phase. A white lamp was attached to a 3L line as an indication that it was being fed electrical power from a suitable source.

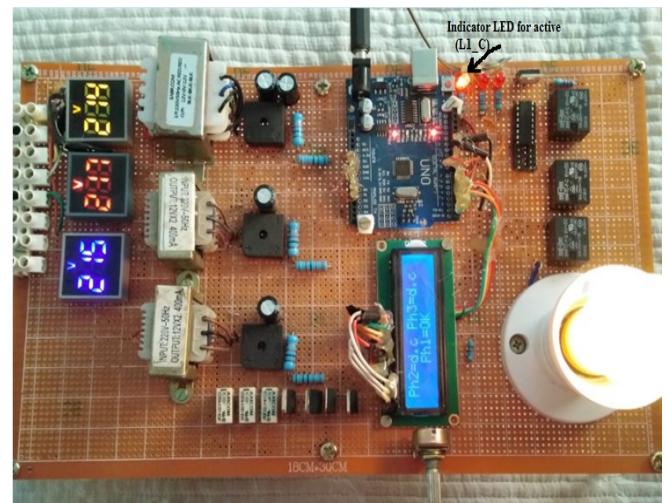

Fig 4. Prototype circuit connection at normal operation

Three power sources priority checking, starts from sensing the three phases coming from the national grid to the home. By analysis the first phase connect to analog input (A1), then the second phase connected to analog input (A2), finally the there'd phase connected to analog input (A3).

First priority for power source is the first phase, if the voltage level reading for it is correct, i.e. within the standard level, so this line becomes a power supply source for 3L, if not, transferred to the second priority then to there'd priority.

But if there is a problem with the voltage reading level of all three phases, such as being higher or lower than the standard level, then the power supply is transferred to another source, which is the voltage regulator.

TABLE I
PRIORITY LEVELS AND OUTPUT POWER SOURCE TYPE

Priority level 1	Priority level 2	Priority level 3	Priority level 4	Priority level 5	Control signal	3L Power source
Ph.1 Level voltage	Ph.2 Level voltage	Ph.3 Level voltage	VR	UPS		
Normal	Don't care	Don't care	Don't care	Don't care	L1_C	Ph1
Low or high	Normal	Don't care	Don't care	Don't care	L2_C	Ph2
Low or high	Low or high	Normal	Don't care	Don't care	L3_C	Ph3
Low or high	Low or high	Low or high	Active	Don't care	VR_C	VR
Cut	Cut	Cut	Don't care	Active	UPS_C	UPS
Cut	Low or high	Normal	Don't care	Don't care	L3_C	Ph3
Low or high	Normal	Don't care	Don't care	Don't care	L2_C	Ph2

Last priority is to switch to the UPS as a source of power supply to 3L. The resort to this source during the occurrence of a state of disconnection in the three phases entering the house, in which case the household energy source will switch to the third source, which is via UPS. Usually, what is resorted to this source is in cases of emergency. Table I summarizes all possibilities and priorities for supplying the 3L to the electrical power source with the required control signals for each case.

VI. SOME CASES OF THE SYSTEM TESTING AND WORKING

To ensure that the proposed system works and responds as planned, it must be exposed to common instances of faults in the national electric power supply grid. It should be noted that the defects are in the form of cutting, weakness, or height in one or more of the phases entering the house. Therefore, some checks are required. The aim of these tests is to ensure that the system can sense and detect the malfunction, the decision taken to determine the priority and whether it is according to the priorities drawn and the mechanism used to connect one of the power sources to 3L. Determining the low or high level is according to demand and can be changed easily, but for examination purposes, assuming that the standard level is within the ranges (180 to 250 volts)

A. Normal three phases

The first test is to check the system's operation with normal conditions, this means, feeding the system with three correct feeders, i.e. the voltage level of all feeders within the standard level. The decision taken in the case is to allow the feeder of higher priority (Ph1) to pass to feed 3L. This is by enable the control signal (L1_C). Activating this control signal causes the indicator LED to glow as shown in Fig. 4, which represents the behavior of the system in this test. Also notice the LCD will display (Ph2=d.c , Ph3=d.c) at first line and (Ph1=ok) at the second line as evidence of the passage of phase one to 3L.

B. Normal Two Phase and Weak One Phase

One of the common faults in the national grid for supplying electricity to homes is a malfunction in one of these inputs to the home. The malfunction is weak the level of voltage in one of these phases, less than the standard level. In this case if the weakness was in the phase one and the other two phases (phase two and three) have normal voltage level. In this case, the decision takes second priority and don't cares for the others which lead to supply the 3L from Ph2, this is by activate the control signal (L2_C). Other things related to this case are the

glow of LED to signify enable of control signal (L2_C). Also the LCD will display the word (ph1=F, ph3=d.c, ph2=ok) this means, phase one fault, phase three don't care and phase two represent the active right phase that connect to 3L. Examination this case is shown in the Fig. 5.

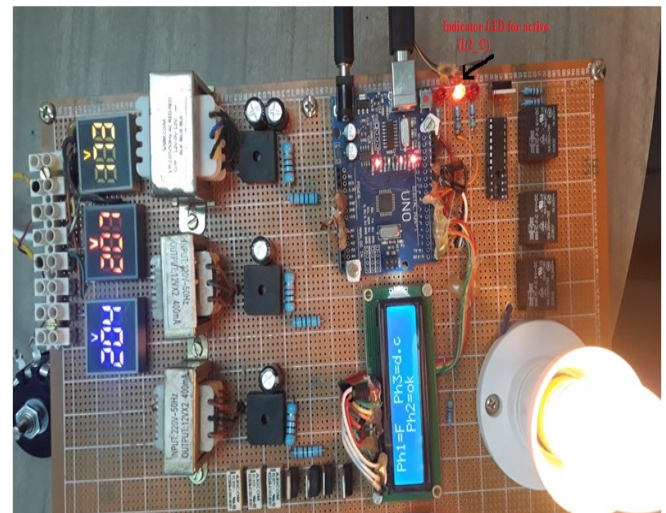

Fig 5. Three-phase are exist but phase one at low level (173 volts)

C. Normal One, Cutting the Other and Weak the There'd

Another situation that may occur is that, the weakness of one of the phases, cut in the other, and the normal condition in the third. The practical application of such a case is as shown in the Fig. 6 when phase one at low level (weak state), phase two is in a cutting state and phase three have normal level. When such case occurs, the logical behavior of the system is to pass the normal level phase to output i.e Ph3 to feed the 3L, this is by activating the control signal (L3_C) and disable the others signals.

This case, as mentioned above, is shown in Fig. 6, where the three input screens display the state of the three phase (Ph1=163 v, Ph2= OFF and Ph3= 201 v), LCD display the system output decision of the three phases (Ph1=F, Ph2= F, Ph3=ok) this means, phase one fault, phase two fault and phase three represent the right output phase that connected to 3L.

The there'd LED will lighted to indicate for enable (L3_C) which means the effectiveness of the normal phase, which is the Ph3 in this case.

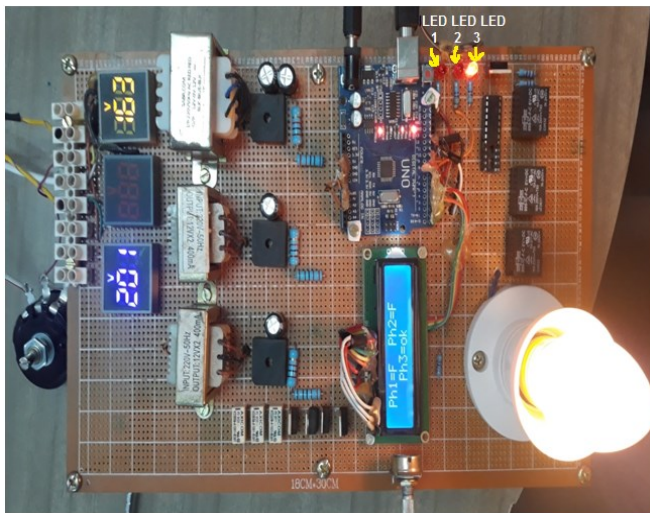

Fig 6. Phase one low level, phase two cut, and phase three at normal level

D. Normal One Phase, Cutting the others two phases

Figure 7 explain other testing case, when two phases one and three are cutting and phase two is right phase. In this case, a decision will be generated that allows the Ph2 to feed the 3L, this is by activating the control signal (L2_C) and disable the others. The second LED will lighted to indicate for enable (L2_C) and LCD will display the word (ph1=F, ph3=F, ph2=ok) this means, phase one fault, phase three fault and phase two represent the right output phase that connected to 3L.



Fig 7. Phase one cut, phase two right, and phase three cut

The behavior of the three phases, as in the four cases mentioned above, is one of the common cases of malfunctions that occur in the national electric power supply network, and it is one of the problems that cause inconvenience to the citizen and waste of money and effort.

For this reason, it was thought to find an automatic method for diagnosing and controlling the malfunction, and as a result, protecting household appliances from damage, which is as was done in this research.

V. CONCLUSION AND FUTURE WORK

In this work, design and implementation of a prototype of a multitasking device to control the electrical energy supply of household appliances connected to a light load line. The proposed device has the automatic ability to control and selection of a safe power source with a protection mechanism when switching between different power sources. The design was carried out in two parts, hardware and software, then assembly these parts together for output with a proposed device. The objectives achieved using this device can be summarized as follows:

1. Continuous supply of electrical appliances connected to 3L of electrical energy for the longest possible period of time.
2. Protect appliances from sudden rise or fall in the energy supply of the national grid.
3. Provides a specific time delay when switching between different power sources. Hence, dispensing with the use of a separate protection device for each appliance.
4. Maintaining the priorities of energy supply sources and voluntary conversion from one source to another without the need for human intervention.
5. Providing excellent protection for the appliances from the rapid extinguishing process and operation, especially those that contain gas compressors such as refrigerators, freezers and water coolers.
6. Eliminating manual switching devices and individual protection devices leads to an economy of effort and money and reduces risks to humans, due to the lack of approaching the sources of lethal effort.
7. Feeling comfortable, safe and reliable to continue operating home appliances during sleep or leaving home.
8. Restriction or limitation of crossing the level of the voltage applied to the 3L within the standard level and not allow the influence of harmful voltages with high and low levels.

The requirements of using this type of devices may cover a wide range places like homes, hospital, warehouse, offices, banks, industries, factories, study halls and various workplaces. This system based on Arduino board, therefore its very useful because its easy to understand and maintenance in addition to other features like small size, low power consumption, low cost, simplicity and reliability. Testing and verification of the system in both parts hardware and software was performed and the proper functioning is ensured. In the future, it's possible to upgrade the system by adding another feature used in emergency cases to enable the customers to change to manual selection instead of automatic selection that may be used as assistance method in case of happen damage or any fault on the proposed device.

VII. REFERENCES

- [1] A. K. Gupta, C. Singh, G. Singh, and A. Kumar, "Automatic cost effective phase selector," International journal of advanced research in electrical, electronics and instrumentation engineering, vol. 4, no. 5, pp. 3919-3925, May 2015. <https://doi.org/10.15662/ijareeie.2015.0405019>
- [2] Z. He, and Y. Du, "SPD Protection Distances to Household Appliances Connected in Parallel" IEEE Transactions on Electromagnetic

- Compatibility, vol. 56, no. 6, pp. 1377 – 1385, Dec. 2014, <https://doi.org/10.1109/TEM.C.2014.2356400>
- [3] G. Ofualagba and E. E. Udoha, “Design and Simulation of Automatic Phase Selector and Changeover Switch for 3-Phase Supply,” *International Journal of Novel Research in Electrical and Mechanical Engineering*, vol. 4, no. 2, pp. 28-35, May - August 2017.
- [4] A. Ghosh, S. Chattaraj, S. Das and K. Mallick, “Design of Automatic Phase Selector From Any Available Three Phase Supply,” *International Journal of Scientific and Engineering Research*. vol. 7, no. 2, pp. 854-856, February 2016.
- [5] O. Oritselaju and F. Oladipo, “Automatic Transfer Switch With Three Phase Selector,” *International Journal of Scientific and Engineering Research*, vol. 6, no. 7, pp. 81-87, July 2015.
- [6] J. Sh. Jahlool, “Automatic Detection and Correction the Fault in Electrical Power Feeders Based Microcontroller,” *Journal of electrical and electronic system*, vol. 7, no. 3, pp. 1 -6, July 2018.
- [7] N. V. Hendwe, S. S. Vaidya, Ch. B. Bhagat and P. V. Raut, “An Automatic Phase Selector from any Available Three Phase Supply System,” *International Research Journal of Engineering and Technology*, vol. 7, no. 2, pp. 2981-2984, Feb. 2020.
- [8] S. G. Naik, V. Ravi, and R. Arshiya, “Programmable Protective device for LV distribution system protection,” *Protection and Control of Modern Power Systems*, 14 September 2018, <https://doi.org/10.1186/s41601-018-0101-5>
- [9] M. Pual, A. Chaudhury, and S. Saikia, “Hardware implementation of over voltage and under voltage protection,” *International Journal of Innovative Research in Electrical, Electronics, Instrumentation and Control Engineering*. vol. 3, no. 6, pp. 140-144, June 2015. <https://doi.org/10.17148/IJIREEICE.2015.3631>
- [10] G. M. Bhutto, B. B. Jensen, C. L. Bak. and J. R. Pillai, “Protection of low voltage CIGRE distribution network” *Smart Grid and Renewable Energy*, vol. 4, pp. 489–500, January 2013. <https://doi.org/10.4236/sgre.2013.49056>
- [11] G. Bhosale, A. Vakhare, A. Kaystha, A. Aher and V. Pansare, “Over voltage, under voltage protection of electrical equipment” *International Research Journal of Engineering and Technology*. vol. 5, no. 2, pp. 29-32, Feb. 2018.
- [12] G. Stokes and J. Bradle, “A Practical Guide to the Wiring Regulations” 17th edition IEE wiring regulations (BS 7671:2008) Wiley online library, 2009.
- [13] L. Louis, “working principle of arduino and using as a tool for study and research,” *International Journal of Control, Automation, Communication and Systems*. vol. 1, no. 2, pp. 21–29, April 2016.
- [14] K. S. Kaswan, S. P. Singh, and Sh. Sagar, “Role Of Arduino In Real World Applications,” *International Journal of Scientific and Technology Research*, vol. 9, no. 01, pp. 1113-1116, January 2020.
- [15] Y. A. Badamasi, “The Working Principle of an Arduino,” 11th International Conference on Electronics, Computer and Computation (ICECCO) . Abuja, 29 Sept to 1 Oct., pp. 1-4, (2014), <https://doi.org/10.1109/ICECCO.2014.6997578>
- [16] D. Anusha, P. M. Sarma and M. N. SandhyaRani, “Appliance Remote Control Using Arduino,” *International Journal of Latest Trends in Engineering and Technology*. vol. 2, no.4, pp. 35-41, July 2013.
- [17] Toshiba. ULN2003APG.[cited 2018; Available from: https://datasheet.lcsc.com/szlcsc/ULN2004APG_C14336.pdf
- [18] E. Yilmazlar, V. Erdemirray, H. Kuscü and Volkan E., Hilmi K. and A. Güllü, “Design Of Stepper Motor Control Interface With Embedded Systems,” *International Journal of Engineering Research and Development*, vol. 14, no. 6, pp. 17-22, June 2018.
- [19] D. Čika and D. Grundler, “Proteus Virtual System Modeling Used for Microcontroller Education” 33rd International Convention MIPRO, 24-28, May 2010.
- [20] Ch. Fan, X. Liu, R. Ling and B. Si, “Application of proteus in Experimental Teaching and Research of Medical Electronic Circuit,” *Advances in Social Science, Education and Humanities Research*, 3rd International Conference on Modern Management, Education Technology, and Social Science (MMETSS), vol. 215, pp. 512-515, January 2018, <https://doi.org/10.2991/mmetss-18.2018.108>