

Comparison of MPPT optimization methods for P&O and PSO solar panels to overcome partial shading

Imelda Uli Vistalina Simanjuntak, Junas Haidi, Ricky Fajar Ade Putra,
and Lukman Medriavin Silalahi

Abstract—Solar panels in enclosed areas are prone to suboptimal absorption of sunlight due to unstable sunshine. Two methods to optimize solar panel efficiency are available: dynamic and static. The dynamic method involves moving the panels towards the sun to maximize solar irradiation, while the static method uses a power converter to find the maximum power point. This research evaluates the performance of the MPPT system, which uses the P&O method with PSO, on solar panels. The objective is to determine the most appropriate MPPT algorithm to optimize the efficiency of solar panels. The MPPT system's efficiency is tested under partial shading conditions of 100 w/m², 300 w/m², and 500 w/m². The system's output is evaluated based on the highest efficiency parameter value. The efficiency of the P&O and PSO methods is compared, and the most optimal efficiency is determined. The MPPT system is designed to measure parameters that are demonstrated qualitatively.

Keywords—MPPT; Observe and observe; Particle swarm Optimization; Simulink matlab; Solar panels

I. INTRODUCTION

INDONESIA as a country located on the equator, it is highly suitable for utilizing solar energy as a source of renewable energy. Solar panels are responsible for converting sunlight into electrical energy, and there are two installation techniques used for storing the electric charges: stand-alone and on-grid photovoltaic (PV).

Solar energy is a great source of renewable energy for a country located on the equator. Solar panels convert sunlight into electrical energy and can be optimized using dynamic or static methods. Maximum Power Point Tracking (MPPT) technology can be used to track the maximum power point that Photovoltaic (PV) can emit when used without the State Electricity Generation (PLN) network. MPPT is preferred over Pulse Width Modulation (PWM) because it can convert excess voltage to high current for the battery. The DC-DC converter and MPPT algorithm method are the two main parts of MPPT technology.

Solar panels produce non-linear current and voltage output, making it challenging to obtain power from them due to their

dependency on natural conditions like temperature and radiation. Various algorithms have been developed to overcome this challenge, including P&O, Fuzzy Logic, and Incremental Conductance. The P&O algorithm adjusts the solar panel voltage until it reaches the Maximum Power Point. In the context of comparing MPPT optimization methods for P&O and PSO solar panels to overcome partial shading, several problem formulations are being discussed, such as the characteristics of solar panels and their efficiency in unshaded and partially shaded conditions.

This research aims to find the maximum power point of a solar panel, with or without a Boost Converter, by varying the duty cycle on the DC-DC converter until maximum power is achieved [1], [2], [3]. The MPPT system will be simulated using Simulink/Matlab. Previous studies have also investigated optimizing solar panel charging with MPPT. Results showed that MPPT solar charge controllers charge batteries faster and more efficiently than other controllers [4], [5], [6]. However, these studies only tested one panel and yielded suboptimal results.

The research used 4x50 Watt-Peak solar panels in parallel, but the parallel series analysis is unknown. Mirza AF, et al used PSO method for MPPT optimization in shading areas [7]. Reference [8], [9], [10], [11], [12] The PV consists of several circuits, and the Boost Converter is controlled by the PSO Algorithm. With this control system, the PV model is expected to have maximum power according to the voltage.

This research compares the optimization performance of MPPT P&O and PSO methods on solar panels under partial shading conditions. The study determines the initial PV output characteristics after using a boost converter, P&O, and PSO. The results are then compared and adjusted to meet environmental conditions and market requirements.

II. RESEARCH METHOD

A. Research Flow Diagram

The research method used to compare P&O and PSO Solar Panel MPPT Optimization methods to overcome partial shading is carried out through the stages outlined in Figure 1.

The first, and fourth authors are with Universitas Mercu Buana, Indonesia (email: imelda.simanjuntak@mercubuana.ac.id, lukmanmedriavinsilalahi@lecturer.unsia.ac.id).

Second Author is with Universitas Bengkulu (email: junas.haidi@unib.ac.id).
Third Author is with PLN Indonesia (email: rickyfajaradeputra@gmail.com).



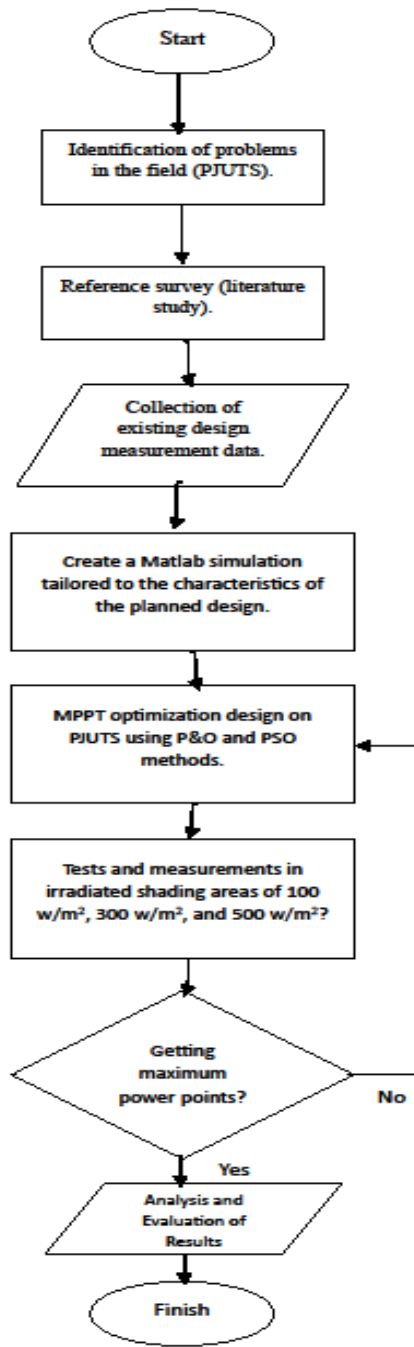

Fig. 1. Research flow diagram

The research stage begins with a literature study on series-parallel PV design. Then, the characteristics of PV, the MPPT system circuit, and the MPPT system workings are understood. Once the expected PV characteristics for food loading are obtained, the process of simulating PV characteristics is carried out in unshaded conditions, partial shading conditions, and full shading conditions. An MPPT system is then created, optimized using the Perturb and Observe algorithm and Particle Swarm Optimization methods to get maximum power points (MPP)[13], [14], [15], [16], [17]. Finally, the algorithm is analyzed, and conclusions are drawn.

B. System Flow Diagram

The entire system will be designed using Matlab/Simulink. The initial design will simulate the non-linear output characteristics of solar panels (PV). Subsequently, an optimization process will be performed to determine the maximum power points (MPP) and efficiency values [18], [19]. These will then be supplied to a load that is connected in parallel with the battery, as illustrated in Figure 2.

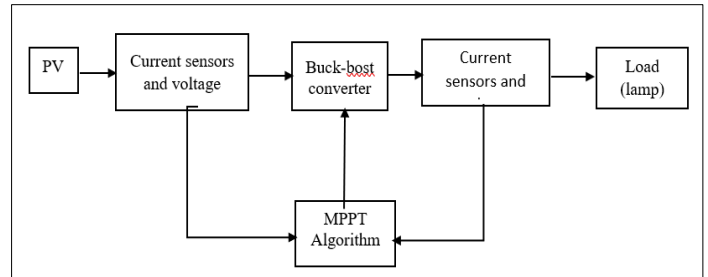

Fig. 2. MPPT System Block

The PV optimization method uses two algorithms: P&O and PSO [19], [20], [21], [22], [23]. Figure 3 illustrates the workflow of P&O. P&O aims to ensure optimal PV output in terms of current and voltage, which are then calculated into power. If the particle value is still suboptimal, it will add value and recalculate the fitness value. If the second value is better, then the maximum power point is found.

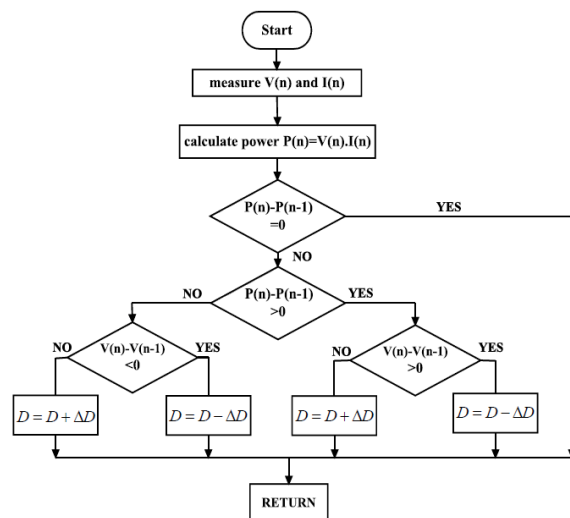

Fig. 3. P&O flowchart

This paragraph explains how the Particle Swarm Optimization (PSO) method works, which is different from the P&O value that moves gradually. PSO method spreads particles throughout the value search field, and if a smaller value is found, the particles with the smaller value will move randomly to explore another value. After the particle moves to a new position, it compares its value with the other particles' values to see which particle has the higher value. This process continues until the best value is found [24], [25], [26]. The Figure 4 flowchart provides a graphical representation of the PSO algorithm.

III. RESULT AND DISCUSSION

A. Solar Panel Characteristics Test Results

The Visero 20 WP panel was tested under irradiation conditions of 1000 W/m², 500 W/m², and 100 W/m² with an optimal temperature of 25°C, and its characteristics are shown in Figure 6.

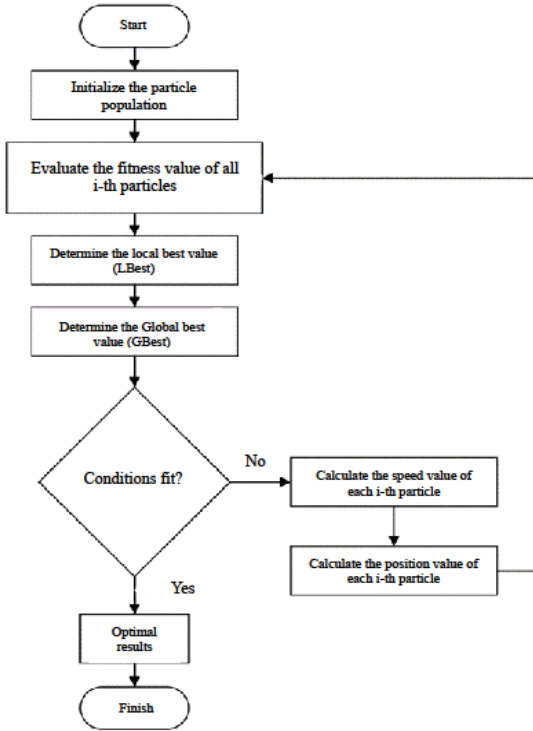

Fig. 4. PSO flowchart

1) MPPT system modeling

The model depicted in Figure 5 shows that there are a total of 6 panels arranged in 3 series and 2 parallel. A C filter of 0.001 F is situated between the panel circuit and the boost converter circuit. The MPPT process results are regulated on the panel's output side. The algorithm utilized for the process employs code via a Matlab function which then connects directly to Simulink.

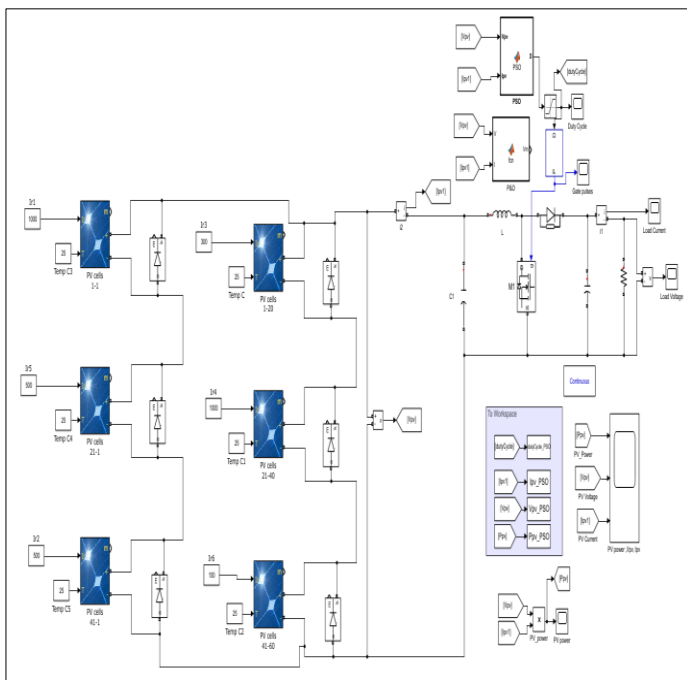

Fig. 5. MPPT system design

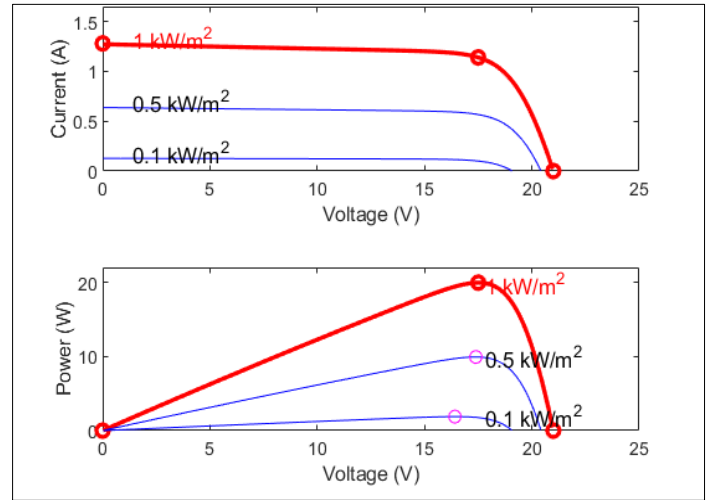

Fig. 6. Characteristics of one 20 WP PV under several conditions

During the testing of optimal conditions, the values obtained at 1000 W/m² were a maximum power point current (MPP) of 1.14 A and a voltage of 17.5 V. This resulted in a power output of 19.95 WP. At 500 W/m², a maximum power of 9.92 WP was obtained at a voltage of 17.3879 V. For panels exposed to irradiation of 100 W/m², a maximum power of 1.88 WP was obtained at a voltage of 16.41 V.

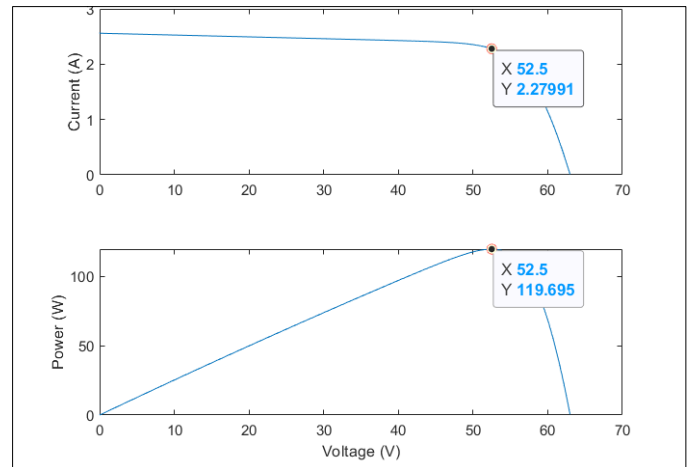

Fig. 7. Characteristics of solar panels when connected in series and parallel without shading

Six Visero panels are combined, with two panels in parallel and three in series for a total of six panels. The panels generate a maximum power output of 119.7 WP with 52.5 V and 2.28 A current. When panels 1, 2, 3, 5, and 6 are shaded and panel 4 is unshaded, the maximum power point is located at 60.9 WP with 1.15 A current and 52.9 V voltage.

Solar panels 1, 3, 5, and 6 produced 62.8 WP at 53.9 V with 500 W/m² shading. Panels 2 and 4 were not shaded and rated at 1000 W/m². In the next test, panels 1 and 3 had 300 W/m² shading, panel 5 had 500 W/m² shading. The peak in the middle produced 52 WP at 34.8 V. Panels 2, 4, and 6 were not affected and rated at 1000 W/m².

During the test, when panels 1 and 5 were exposed to an irradiation value of 100 W/m², and panel 6 was exposed to 300 W/m², panels 3 and 4 received 500 W/m². The test produced three local maximums with a peak in the middle, generating a power of 33.5 WP and a voltage of 35.6 V. Panels 1 and 5, which were shaded, performed at 100 W/m², while panels 3 and 4, also shaded, performed at 500 W/m². Meanwhile, panel 6, which was shaded as well, performed at 300 W/m², and panel 2 performed the best at 1000 W/m².

B. Boost Converter

This test aims to determine the traits of the boost converter. The procedure involves gradually increasing the duty cycle value, starting from 0.2 and ascending to 0.4, then 0.5, followed by 0.6, and finally reaching 0.8.

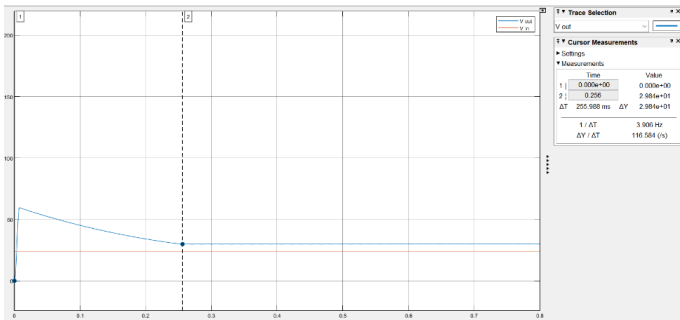

Fig. 8. Characteristics of the boost converter when given a duty cycle of 0.2

Figure 8 is a test graph showing the output voltage values of a boost converter with varying duty cycle values. The input voltage remains constant at 24 V. At a duty cycle of 0.2, the output voltage is 29.4 V, and it takes 255.98 ms to reach a stable voltage.

Increasing the duty cycle to 0.4 results in an output voltage of 40.9 V, which is 1.4 times the output voltage at a duty cycle of 0.2. The time taken to reach a stable voltage is still 255.98 ms. When the duty cycle is increased to 0.5, the output voltage increases to 48.9 V, which is 8.9 V higher than the output voltage at a duty cycle of 0.4. The time taken to reach a stable voltage remains constant at 255.98 ms.

Further increasing the duty cycle to 0.6 results in an output voltage of 60.4 V, which is 11.5 V higher than the output voltage at a duty cycle of 0.5. The time taken to reach a stable voltage is still 255.98 ms. At a duty cycle of 0.8, the output voltage increases to 122.1 V, which is 2 times the output voltage at a duty cycle of 0.6. The time taken to reach a stable voltage remains the same at 255.98 ms.

C. P&O Test Results

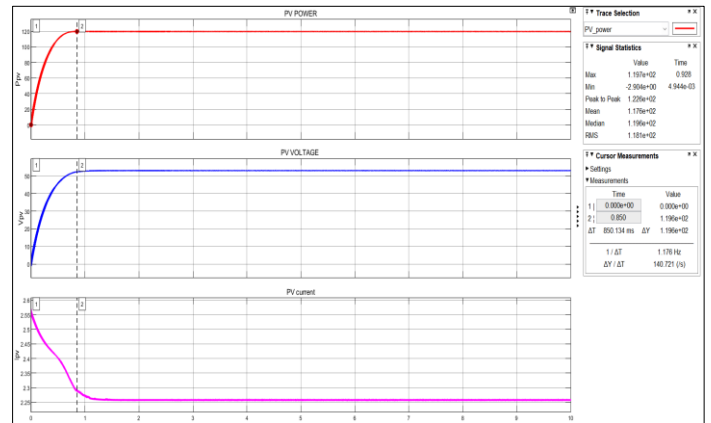

Fig. 9. Test results of the P&O algorithm when the panel is in a condition without shading

In the first test, the solar panel under optimal conditions generated 119.6 WP power output. The time taken to track the maximum power was 850,134 ms. The maximum power output that can be achieved is 119.7 WP with an efficiency of 99.95%. In the second test, the P&O algorithm with shaded solar panels generated a power output of only 20.6 WP. The time taken to stabilize at the maximum point was 1.26 s, with an efficiency value of 33,826%.

In the next test, the P&O algorithm with solar panels experiencing different shading conditions generated a power output of 34.5 WP, with a time taken to stabilize at the maximum point of 1.27 s and an efficiency value of 55.02%. In the fourth test, the P&O algorithm with solar panels experiencing different shading conditions generated a power output of 36 WP, with a time taken to stabilize at the maximum point of 1.8 s and an efficiency value of 38.4%.

In the final test, the P&O algorithm with solar panels experiencing different shading conditions generated a power output of 20.4 WP, with a time taken to stabilize at the maximum point of 1.57 s and an efficiency value of 60.9%.

D. PSO Test Results

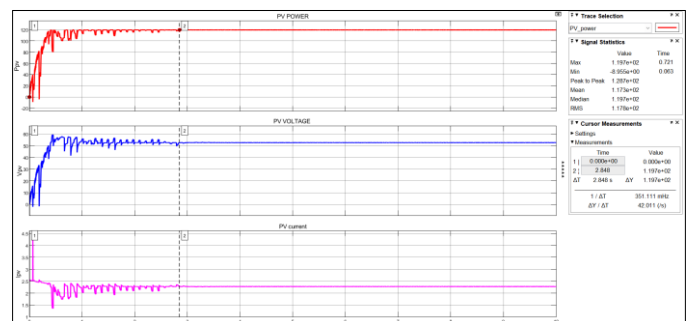

Fig. 10. Test results of the PSO algorithm when the panel is in a condition without shading

In the first test, the solar panel was exposed to direct sunlight without any obstruction, and it produced a power of 119.7 WP under optimal conditions of 1000 W/m^2 . The time taken for the panel to track from zero to the maximum power point was 2,848 s. The summary of the data obtained in Figure 10 shows that the maximum power point achievable is 119.7 WP, which means that the efficiency achieved when compared to the PV characteristics without shading is 100%. The movement of the particles to find the optimal point is clearly visible from time 0 s to 2.8 s as three particles move.

In the PSO algorithm test results, when panels 1, 2, 3, 5, 6 were shading and panel 4 was not in a shading condition, the movement of the swarm particles to find the maximum point was clearly visible before 1.26 s. The results of this movement produced a maximum power point of 60.26 WP, while the simulation results of the maximum power point were 60.9 WP. The comparison of these results shows an efficiency value of 98.95%, indicating that PSO can find the maximum power point well.

In the next test, PSO was tested with solar panels experiencing different shading conditions and produced a value of 61.2 WP. The tracking time to reach the maximum point was 1,154 s. The efficiency value of PSO in finding the maximum power point was 97.45%. This was calculated based on simulation results that obtained a value of 61.2 WP and characteristic results of 62.8%.

The results of testing the PSO algorithm when panels 1, 3, and 5 were experiencing shading and panels 2, 4, and 6 were not showed the ability of PSO to achieve GMPP. The movement of the swarm particles to find the maximum point was clearly visible before 2,475 s, and the power obtained was 52 WP with a tracking time of 1,199 s. The results of this movement produced a maximum power point of 33.44 WP, while the simulation produced a maximum power point of 33.45 WP. The comparison of the simulation results and the panel characteristics showed an efficiency of 99.97%, indicating that PSO is capable of finding the maximum power point accurately.

E. Dynamic test

The test results presented here demonstrate the performance of two algorithms: PSO and P&O. The performance of the PSO algorithm is illustrated in Figure 11, while the P&O algorithm results are shown in Figure 12. The test results indicate that both algorithms are capable of responding to changes in irradiation. The response of the algorithms to changes in irradiation from 100 W/m^2 to 1000 W/m^2 and back to 100 W/m^2 was satisfactory. Although the PSO algorithm was unable to respond up to the

maximum power point at 1000 W/m^2 , it performed well below 500 W/m^2 and was able to reach the maximum power point.

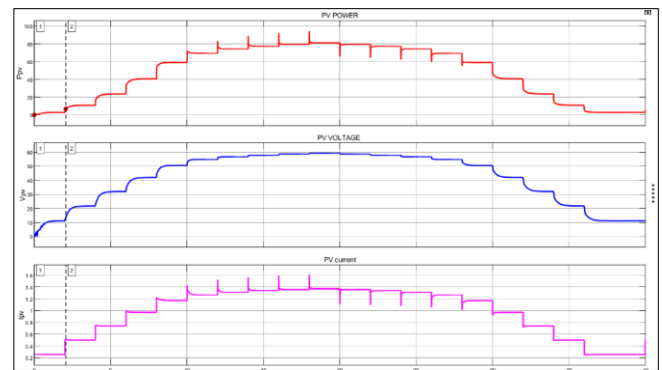

Fig. 11. Dynamic test results from PSO

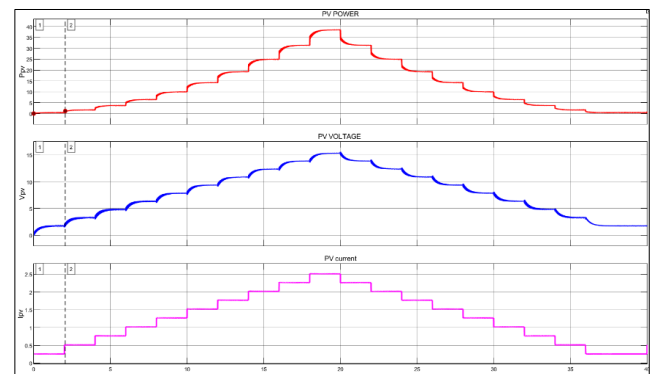

Fig. 12. Dynamic test results from P&O

F. Comparison of P&O and PSO

Based on the results of all the tests presented in Table 5, it can be concluded that PSO is more efficient than P&O on average. The lowest efficiency of 97.45% was observed in the conditions of shading in panels 1, 3, 5, and 6, and no shading in panels 4 and 2. On the other hand, the highest efficiency was observed in panels with no shading and panels 1, 3, and 5 with shading, and panels 2, 4, and 6 with no shading, which is 100%. While P&O is faster in the no shading panel condition, PSO is superior in multiple peak conditions even though it takes longer to search for the maximum power point. Since PSO is more efficient, the power obtained through PSO is automatically higher on average than P&O.

TABLE V
SUMMARY OF COMPARISON RESULTS OF PSO AND P&O ALGORITHM TESTING

Scenario	Tracking Time		Power (WP)		Efficiency (%)	
	PSO	P&O	PSO	P&O	PSO	P&O
No shading	2.8 s	850.2 ms	119.7	119.6	100	99.95
Panel 1,2,3,5,6 shading & panel 4 No shading	1.26 s	1.26 s	60.26	20.6	98.95	33.826
Panel 1,3,5,6 shading & panel 4 dan panel 2 No shading	1.15 s	1.27 s	61.2	34.5	97.45	55.02
Panel 1, 3 dan 5 shading & panel 2, 4,6 No shading	1.2 s	1.8 s	52	52	100	38.4
Panel 1, 3, 4, 5 dan 6 shading & panel 2 No shading	2.5 s	1.57	33.34	20.4	99.97	60.9

CONCLUSION

After conducting a thorough literature study, design, testing, and final analysis, the following conclusions have been drawn. The MPPT P&O method is the most optimal when used in non-shading or obstacle-free conditions, whereas the optimal PSO algorithm is used when solar panels experience partial shading. When several panels are exposed to different irradiation conditions with values of 100 W/ m², 300 W/ m², and 500 W/ m², they may produce varying multiple-peak conditions depending on the location of the panel experiencing shading. The lowest efficiency of PSO was 97.45%, while the highest was 100%, whereas P&O had the lowest efficiency of 33.826% and the highest was 99.95%. P&O obtained the fastest tracking time with a record time of 850.2 ms, whereas the PSO algorithm took the longest time of 2.8 seconds. The tests conducted on solar panels to obtain PV characteristics and overcome the condition of partial shading were successful. They can be efficiently implemented in Simulink Matlab.

ACKNOWLEDGEMENTS

We would like to thank Universitas Mercu Buana and Universitas Negeri Bengkulu, Indonesia for the domestic co-operation research, hopefully this article will be published and become a consumption for scholars.

REFERENCES

- [1] M. Alagu, P. Ponnusamy, S. Pandarinathan, and J. S. Mohamed Ali, "Performance improvement of solar PV power conversion system through low duty cycle DC-DC converter," *International Journal of Circuit Theory and Applications*, vol. 49, no. 2, pp. 267–282, 2021. <https://doi.org/10.1002/cta.2918>
- [2] A. Rajavel and N. Rathina Prabha, "Fuzzy logic controller-based boost and buck-boost converter for maximum power point tracking in solar system," *Transactions of the Institute of Measurement and Control*, vol. 43, no. 4, pp. 945–957, 2021. <https://doi.org/10.1177/0142331220938211>
- [3] A. Charaabi, O. Barambones, A. Zaidi, and N. Zanzouri, "A novel two stage controller for a DC-DC boost converter to harvest maximum energy from the PV power generation," in *Actuators*, MDPI, 2020, p. 29. <https://doi.org/10.3390/act9020029>
- [4] K. Ananda-Rao, Y. Matar, N. H. Baharudin, M. A. Ismail, and A. M. Abdullah, "Design of MPPT charge controller using zeta converter for battery integrated with solar Photovoltaic (PV) system," in *Journal of Physics: Conference Series*, IOP Publishing, 2020, p. 012058. <https://doi.org/10.1088/1742-6596/1432/1/012058>
- [5] P. K. Atri, P. S. Modi, and N. S. Gujar, "Comparison of different MPPT control strategies for solar charge controller," in *2020 International Conference on Power Electronics & IoT Applications in Renewable Energy and its Control (PARC)*, IEEE, 2020, pp. 65–69. <https://doi.org/10.1109/PARC49193.2020.236559>
- [6] C. Lapsongphon and S. Nualyai, "A comparison of MPPT solar charge controller techniques: a case for charging rate of battery," in *2021 Research, Invention, and Innovation Congress: Innovation Electricals and Electronics (RI2C)*, IEEE, 2021, pp. 278–281. <https://doi.org/10.1109/RI2C51727.2021.9559787>
- [7] A. F. Mirza, M. Mansoor, Q. Ling, B. Yin, and M. Y. Javed, "A Salp-Swarm Optimization based MPPT technique for harvesting maximum energy from PV systems under partial shading conditions," *Energy Convers Manag*, vol. 209, p. 112625, 2020. <https://doi.org/10.1016/j.enconman.2020.112625>
- [8] W. Hayder, A. Abid, M. Ben Hamed, and L. Sbita, "MPPT based on P &O method under partially shading," in *2020 17th International Multi-Conference on Systems, Signals & Devices (SSD)*, IEEE, 2020, pp. 538–542. <https://doi.org/10.1109/SSD49366.2020.9364107>
- [9] M. Joisher, D. Singh, S. Taheri, D. R. Espinoza-Trejo, E. Pouresmaeil, and H. Taheri, "A hybrid evolutionary-based MPPT for photovoltaic systems under partial shading conditions," *IEEE Access*, vol. 8, pp. 38481–38492, 2020. <https://doi.org/10.1109/ACCESS.2020.2975742>
- [10] A. M. Eltamaly, H. M. H. Farh, and A. G. Abokhalil, "A novel PSO strategy for improving dynamic change partial shading photovoltaic maximum power point tracker," *Energy sources, part a: recovery, utilization, and environmental effects*, pp. 1–15, 2020. <https://doi.org/10.1080/15567036.2020.1769774>
- [11] J. Farzaneh, R. Keypour, and A. Karsaz, "A novel fast maximum power point tracking for a PV system using hybrid PSO-ANFIS algorithm under partial shading conditions," *International Journal of Industrial Electronics Control and Optimization*, vol. 2, no. 1, pp. 47–58, 2019. <https://doi.org/10.22111/IECO.2018.25721.1056>
- [12] N. Shankar and N. SaravanaKumar, "Reduced partial shading effect in multiple PV array configuration model using MPPT based enhanced particle swarm optimization technique," *Microprocess Microsyst*, p. 103287, 2020. <https://doi.org/10.1016/j.micpro.2020.103287>
- [13] A. Mohapatra, B. Nayak, and C. Saiprakash, "Adaptive perturb & observe MPPT for PV system with experimental validation," in *2019 IEEE International Conference on Sustainable Energy Technologies and Systems (ICSETS)*, IEEE, 2019, pp. 257–261. <https://doi.org/10.1109/ICSETS.2019.8744819>
- [14] A. F. Mirza, Q. Ling, M. Y. Javed, and M. Mansoor, "Novel MPPT techniques for photovoltaic systems under uniform irradiance and Partial shading," *Solar Energy*, vol. 184, pp. 628–648, 2019.
- [15] M. Joisher, D. Singh, S. Taheri, D. R. Espinoza-Trejo, E. Pouresmaeil, and H. Taheri, "A hybrid evolutionary-based MPPT for photovoltaic systems under partial shading conditions," *IEEE Access*, vol. 8, pp. 38481–38492, 2020. <https://doi.org/10.1109/ACCESS.2020.2975742>
- [16] H. Li, D. Yang, W. Su, J. Lü, and X. Yu, "An overall distribution particle swarm optimization MPPT algorithm for photovoltaic system under partial shading," *IEEE Transactions on Industrial Electronics*, vol. 66, no. 1, pp. 265–275, 2018. <https://doi.org/10.1109/TIE.2018.2829668>
- [17] P. S. Acharya and P. S. Aithal, "A Comparative Study of MPPT and PWM Solar Charge Controllers and their Integrated System," in *Journal of Physics: Conference Series*, IOP Publishing, 2020, p. 012023. <https://doi.org/10.1088/1742-6596/1712/1/012023>
- [18] B. Dwinanto, "MPPT PV Modeling with ANN Using Matlab Simulink," *Eduvest-Journal of Universal Studies*, vol. 2, no. 8, pp. 1–609, 2022. <https://doi.org/10.36418/eduvest.v2i8.554>
- [19] K. O. Sarfo, W. M. Amuna, B. N. Pouliwe, and F. B. Effah, "An Improved P&O MPPT Algorithm Under Partial Shading Conditions," in *2020 IEEE PES/IAS PowerAfrica*, IEEE, 2020, pp. 1–5. <https://doi.org/10.1109/PowerAfrica49420.2020.9219851>
- [20] A. Rajagukguk and M. Aritonang, "Optimization of PV Power Capacity of 10 KWp Capacity Based on P&O Algorithm and Boost Converter," *International Journal of Electrical, Energy and Power System Engineering*, vol. 3, no. 3, pp. 57–64, 2020. <https://doi.org/10.31258/ijeepse.3.3.57-64>

- [21] W. A. Santosa, S. Anam, and F. A. Pamuji, "Design and Implementation of Solar Charge Controller with P&O MPPT for Light-Fishing in Ujung Pangkah, Gresik," *JAREE (Journal on Advanced Research in Electrical Engineering)*, vol. 4, no. 1, 2020. <https://doi.org/10.12962/j25796216.v4.i1.82>
- [22] W. Hayder, E. Ogliari, A. Dolara, A. Abid, M. Ben Hamed, and L. Sbita, "Improved PSO: A comparative study in MPPT algorithm for PV system control under partial shading conditions," *Energies (Basel)*, vol. 13, no. 8, p. 2035, 2020. <https://doi.org/10.3390/en13082035>
- [23] W. Hayder, E. Ogliari, A. Dolara, A. Abid, M. Ben Hamed, and L. Sbita, "Improved PSO: A comparative study in MPPT algorithm for PV system control under partial shading conditions," *Energies (Basel)*, vol. 13, no. 8, p. 2035, 2020. <https://doi.org/10.3390/en13082035>
- [24] Z. Iklima, A. Adriansyah, and S. Hitimana, "Self-collision avoidance of arm robot using generative adversarial network and particles swarm optimization (gan-pso)," *Sinergi*, vol. 25, no. 2, pp. 141–152, 2021. <https://doi.org/10.22441/sinergi.2021.2.005>
- [25] A. Adriansyah, S. H. M. Amin, A. Minarso, and E. Ihsanto, "Improvement of quadrotor performance with flight control system using particle swarm proportional-integral-derivative (PS-PID)," *J Teknol*, vol. 79, no. 6, 2017. <https://doi.org/10.11113/jt.v79.10680>
- [26] A. Adriansyah and E. Ihsanto, "Design of Goal-Seeking Behavior-Based Mobile Robot Using Particle Swarm Fuzzy Controller," *Jurnal Ilmiah Kursor*, vol. 7, no. 3, 2014.